

# Welcome to Comprehensive Rust

build **passing** contributors **312** stars **30k**

This is a free Rust course developed by the Android team at Google. The course covers the full spectrum of Rust, from basic syntax to advanced topics like generics and error handling.

---

The latest version of the course can be found at <https://google.github.io/comprehensive-rust/>. If you are reading somewhere else, please check there for updates.

The course is available in other languages. Select your preferred language in the top right corner of the page or check the [Translations](#) page for a list of all available translations.

The course is also available [as a PDF](#).

---

The goal of the course is to teach you Rust. We assume you don't know anything about Rust and hope to:

- Give you a comprehensive understanding of the Rust syntax and language.
- Enable you to modify existing programs and write new programs in Rust.
- Show you common Rust idioms.

We call the first four course days Rust Fundamentals.

Building on this, you're invited to dive into one or more specialized topics:

- **Android**: a half-day course on using Rust for Android platform development (AOSP). This includes interoperability with C, C++, and Java.
- **Chromium**: a half-day course on using Rust within Chromium based browsers. This includes interoperability with C++ and how to include third-party crates in Chromium.
- **Bare-metal**: a whole-day class on using Rust for bare-metal (embedded) development. Both microcontrollers and application processors are covered.
- **Concurrency**: a whole-day class on concurrency in Rust. We cover both classical concurrency (preemptively scheduling using threads and mutexes) and async/await concurrency (cooperative multitasking using futures).

## Non-Goals

Rust is a large language and we won't be able to cover all of it in a few days. Some non-goals of this course are:

- Learning how to develop macros: please see [Chapter 19.5 in the Rust Book](#) and [Rust by Example](#) instead.

## Assumptions

The course assumes that you already know how to program. Rust is a statically-typed language and we will sometimes make comparisons with C and C++ to better explain or contrast the Rust approach.

If you know how to program in a dynamically-typed language such as Python or JavaScript, then you will be able to follow along just fine too.

### ▼ *Speaker Notes*

This is an example of a *speaker note*. We will use these to add additional information to the slides. This could be key points which the instructor should cover as well as answers to typical questions which come up in class.

# Running the Course

---

This page is for the course instructor.

---

Here is a bit of background information about how we've been running the course internally at Google.

We typically run classes from 9:00 am to 4:00 pm, with a 1 hour lunch break in the middle. This leaves 3 hours for the morning class and 3 hours for the afternoon class. Both sessions contain multiple breaks and time for students to work on exercises.

Before you run the course, you will want to:

1. Make yourself familiar with the course material. We've included speaker notes to help highlight the key points (please help us by contributing more speaker notes!). When presenting, you should make sure to open the speaker notes in a popup (click the link with a little arrow next to "Speaker Notes"). This way you have a clean screen to present to the class.
2. Decide on the dates. Since the course takes four days, we recommend that you schedule the days over two weeks. Course participants have said that they find it helpful to have a gap in the course since it helps them process all the information we give them.
3. Find a room large enough for your in-person participants. We recommend a class size of 15-25 people. That's small enough that people are comfortable asking questions — it's also small enough that one instructor will have time to answer the questions. Make sure the room has *desks* for yourself and for the students: you will all need to be able to sit and work with your laptops. In particular, you will be doing a lot of live-coding as an instructor, so a lectern won't be very helpful for you.
4. On the day of your course, show up to the room a little early to set things up. We recommend presenting directly using `mdbook serve` running on your laptop (see the [installation instructions](#)). This ensures optimal performance with no lag as you change pages. Using your laptop will also allow you to fix typos as you or the course participants spot them.
5. Let people solve the exercises by themselves or in small groups. We typically spend 30-45 minutes on exercises in the morning and in the afternoon (including time to review the solutions). Make sure to ask people if they're stuck or if there is anything you can help with. When you see that several people have the same problem, call it out to the class and

offer a solution, e.g., by showing people where to find the relevant information in the standard library.

That is all, good luck running the course! We hope it will be as much fun for you as it has been for us!

Please [provide feedback](#) afterwards so that we can keep improving the course. We would love to hear what worked well for you and what can be made better. Your students are also very welcome to [send us feedback](#)!

# Course Structure

---

This page is for the course instructor.

---

## Rust Fundamentals

The first four days make up [Rust Fundamentals](#). The days are fast paced and we cover a lot of ground!

Course schedule:

- Day 1 Morning (2 hours and 10 minutes, including breaks)

Segment	Duration
Welcome	5 minutes
Hello, World	15 minutes
Types and Values	40 minutes
Control Flow Basics	45 minutes

- Day 1 Afternoon (2 hours and 45 minutes, including breaks)

Segment	Duration
Tuples and Arrays	35 minutes
References	55 minutes
User-Defined Types	1 hour

- Day 2 Morning (2 hours and 45 minutes, including breaks)

Segment	Duration
Welcome	3 minutes
Pattern Matching	50 minutes
Methods and Traits	45 minutes
Generics	45 minutes

- Day 2 Afternoon (2 hours and 40 minutes, including breaks)

Segment	Duration
Standard Library Types	1 hour
Standard Library Traits	1 hour
Closures	20 minutes

- Day 3 Morning (2 hours and 20 minutes, including breaks)

Segment	Duration
Welcome	3 minutes
Memory Management	1 hour
Smart Pointers	55 minutes

- Day 3 Afternoon (1 hour and 55 minutes, including breaks)

Segment	Duration
Borrowing	55 minutes
Lifetimes	50 minutes

- Day 4 Morning (2 hours and 50 minutes, including breaks)

Segment	Duration
Welcome	3 minutes
Iterators	55 minutes
Modules	45 minutes
Testing	45 minutes

- Day 4 Afternoon (2 hours and 20 minutes, including breaks)

Segment	Duration
Error Handling	55 minutes
Unsafe Rust	1 hour and 15 minutes

## Deep Dives

In addition to the 4-day class on Rust Fundamentals, we cover some more specialized topics:

## Rust in Android

The [Rust in Android](#) deep dive is a half-day course on using Rust for Android platform development. This includes interoperability with C, C++, and Java.

You will need an [AOSP checkout](#). Make a checkout of the [course repository](#) on the same machine and move the `src/android/` directory into the root of your AOSP checkout. This will ensure that the Android build system sees the `Android.bp` files in `src/android/`.

Ensure that `adb sync` works with your emulator or real device and pre-build all Android examples using `src/android/build_all.sh`. Read the script to see the commands it runs and make sure they work when you run them by hand.

## Rust in Chromium

The [Rust in Chromium](#) deep dive is a half-day course on using Rust as part of the Chromium browser. It includes using Rust in Chromium's `gn` build system, bringing in third-party libraries ("crates") and C++ interoperability.

You will need to be able to build Chromium — a debug, component build is [recommended](#) for speed but any build will work. Ensure that you can run the Chromium browser that you've built.

## Bare-Metal Rust

The [Bare-Metal Rust](#) deep dive is a full day class on using Rust for bare-metal (embedded) development. Both microcontrollers and application processors are covered.

For the microcontroller part, you will need to buy the [BBC micro:bit v2](#) development board ahead of time. Everybody will need to install a number of packages as described on the [welcome page](#).

## Concurrency in Rust

The [Concurrency in Rust](#) deep dive is a full day class on classical as well as `async / await` concurrency.

You will need a fresh crate set up and the dependencies downloaded and ready to go. You can then copy/paste the examples into `src/main.rs` to experiment with them:

```
cargo init concurrency
cd concurrency
cargo add tokio --features full
cargo run
```

Course schedule:

- Morning (3 hours and 20 minutes, including breaks)

Segment	Duration
Threads	30 minutes
Channels	20 minutes
Send and Sync	15 minutes
Shared State	30 minutes
Exercises	1 hour and 10 minutes

- Afternoon (3 hours and 20 minutes, including breaks)

Segment	Duration
Async Basics	30 minutes
Channels and Control Flow	20 minutes
Pitfalls	55 minutes
Exercises	1 hour and 10 minutes

## Format

The course is meant to be very interactive and we recommend letting the questions drive the exploration of Rust!



# Keyboard Shortcuts

There are several useful keyboard shortcuts in mdBook:

- `Arrow-Left`: Navigate to the previous page.
- `Arrow-Right`: Navigate to the next page.
- `Ctrl + Enter`: Execute the code sample that has focus.
- `s`: Activate the search bar.

# Translations

The course has been translated into other languages by a set of wonderful volunteers:

- [Brazilian Portuguese](#) by [@rastringer](#), [@hugojacob](#), [@joaovicmendes](#), and [@henrif75](#).
- [Chinese \(Simplified\)](#) by [@suetfei](#), [@wnghl](#), [@anlunx](#), [@kongy](#), [@noahdragon](#), [@superwhd](#), [@SketchK](#), and [@nodmp](#).
- [Chinese \(Traditional\)](#) by [@hueich](#), [@victorhsieh](#), [@mingyc](#), [@kuanhungchen](#), and [@johnathan79717](#).
- [Farsi](#) by [@DannyRavi](#), [@javad-jafari](#), [@Alix1383](#), [@moaminsharifi](#), [@hamidrezakp](#) and [@mehrads77](#).
- [Japanese](#) by [@CoinEZ-JPN](#), [@momotaro1105](#), [@HidenoriKobayashi](#) and [@kantasv](#).
- [Korean](#) by [@keinspace](#), [@jiyongp](#), [@jooyunghan](#), and [@namhyung](#).
- [Spanish](#) by [@deavid](#).
- [Ukrainian](#) by [@git-user-cpp](#), [@yaremam](#) and [@reta](#).

Use the language picker in the top-right corner to switch between languages.

## Incomplete Translations

There is a large number of in-progress translations. We link to the most recently updated translations:

- [Arabic](#) by [@younies](#)
- [Bengali](#) by [@raselmandol](#).
- [French](#) by [@KookaS](#), [@vcaen](#) and [@AdrienBaudemont](#).
- [German](#) by [@Throvn](#) and [@ronaldfw](#).
- [Italian](#) by [@henrythebuilder](#) and [@detro](#).

The full list of translations with their current status is also available either [as of their last update](#) or [synced to the latest version of the course](#).

If you want to help with this effort, please see [our instructions](#) for how to get going. Translations are coordinated on the [issue tracker](#).

# Using Cargo

When you start reading about Rust, you will soon meet [Cargo](#), the standard tool used in the Rust ecosystem to build and run Rust applications. Here we want to give a brief overview of what Cargo is and how it fits into the wider ecosystem and how it fits into this training.

## Installation

---

Please follow the instructions on <https://rustup.rs/>.

---

This will give you the Cargo build tool ( `cargo` ) and the Rust compiler ( `rustc` ). You will also get `rustup` , a command line utility that you can use to install to different compiler versions.

After installing Rust, you should configure your editor or IDE to work with Rust. Most editors do this by talking to [rust-analyzer](#), which provides auto-completion and jump-to-definition functionality for [VS Code](#), [Emacs](#), [Vim/Neovim](#), and many others. There is also a different IDE available called [RustRover](#).

### ▼ *Speaker Notes*

- On Debian/Ubuntu, you can also install Cargo, the Rust source and the [Rust formatter](#) via `apt` . However, this gets you an outdated Rust version and may lead to unexpected behavior. The command would be:

```
sudo apt install cargo rust-src rustfmt
```

- On macOS, you can use [Homebrew](#) to install Rust, but this may provide an outdated version. Therefore, it is recommended to install Rust from the official site.

# The Rust Ecosystem

The Rust ecosystem consists of a number of tools, of which the main ones are:

- `rustc`: the Rust compiler which turns `.rs` files into binaries and other intermediate formats.
- `cargo`: the Rust dependency manager and build tool. Cargo knows how to download dependencies, usually hosted on <https://crates.io>, and it will pass them to `rustc` when building your project. Cargo also comes with a built-in test runner which is used to execute unit tests.
- `rustup`: the Rust toolchain installer and updater. This tool is used to install and update `rustc` and `cargo` when new versions of Rust are released. In addition, `rustup` can also download documentation for the standard library. You can have multiple versions of Rust installed at once and `rustup` will let you switch between them as needed.

## ▼ *Speaker Notes*

Key points:

- Rust has a rapid release schedule with a new release coming out every six weeks. New releases maintain backwards compatibility with old releases — plus they enable new functionality.
- There are three release channels: “stable”, “beta”, and “nightly”.
- New features are being tested on “nightly”, “beta” is what becomes “stable” every six weeks.
- Dependencies can also be resolved from alternative [registries](#), git, folders, and more.
- Rust also has [editions](#): the current edition is Rust 2021. Previous editions were Rust 2015 and Rust 2018.
  - The editions are allowed to make backwards incompatible changes to the language.
  - To prevent breaking code, editions are opt-in: you select the edition for your crate via the `Cargo.toml` file.
  - To avoid splitting the ecosystem, Rust compilers can mix code written for different editions.

- Mention that it is quite rare to ever use the compiler directly not through `cargo` (most users never do).
- It might be worth alluding that Cargo itself is an extremely powerful and comprehensive tool. It is capable of many advanced features including but not limited to:
  - Project/package structure
  - [workspaces](#)
  - Dev Dependencies and Runtime Dependency management/caching
  - [build scripting](#)
  - [global installation](#)
  - It is also extensible with sub command plugins as well (such as [cargo clippy](#)).
- Read more from the [official Cargo Book](#)

# Code Samples in This Training

For this training, we will mostly explore the Rust language through examples which can be executed through your browser. This makes the setup much easier and ensures a consistent experience for everyone.

Installing Cargo is still encouraged: it will make it easier for you to do the exercises. On the last day, we will do a larger exercise which shows you how to work with dependencies and for that you need Cargo.

The code blocks in this course are fully interactive:

```
1 fn main() {  
2     println!("Edit me!");  
3 }
```

You can use `Ctrl + Enter` to execute the code when focus is in the text box.

## ▼ *Speaker Notes*

Most code samples are editable like shown above. A few code samples are not editable for various reasons:

- The embedded playgrounds cannot execute unit tests. Copy-paste the code and open it in the real Playground to demonstrate unit tests.
- The embedded playgrounds lose their state the moment you navigate away from the page! This is the reason that the students should solve the exercises using a local Rust installation or via the Playground.

# Running Code Locally with Cargo

If you want to experiment with the code on your own system, then you will need to first install Rust. Do this by following the [instructions in the Rust Book](#). This should give you a working `rustc` and `cargo`. At the time of writing, the latest stable Rust release has these version numbers:

```
% rustc --version
rustc 1.69.0 (84c898d65 2023-04-16)
% cargo --version
cargo 1.69.0 (6e9a83356 2023-04-12)
```

You can use any later version too since Rust maintains backwards compatibility.

With this in place, follow these steps to build a Rust binary from one of the examples in this training:

1. Click the “Copy to clipboard” button on the example you want to copy.
2. Use `cargo new exercise` to create a new `exercise/` directory for your code:

```
$ cargo new exercise
Created binary (application) `exercise` package
```

3. Navigate into `exercise/` and use `cargo run` to build and run your binary:

```
$ cd exercise
$ cargo run
Compiling exercise v0.1.0 (/home/mgeisler/tmp/exercise)
Finished dev [unoptimized + debuginfo] target(s) in 0.75s
Running `target/debug/exercise`
Hello, world!
```

4. Replace the boiler-plate code in `src/main.rs` with your own code. For example, using the example on the previous page, make `src/main.rs` look like

```
fn main() {
    println!("Edit me!");
}
```

5. Use `cargo run` to build and run your updated binary:

```
$ cargo run
  Compiling exercise v0.1.0 (/home/mgeisler/tmp/exercise)
  Finished dev [unoptimized + debuginfo] target(s) in 0.24s
  Running `target/debug/exercise`
Edit me!
```

6. Use `cargo check` to quickly check your project for errors, use `cargo build` to compile it without running it. You will find the output in `target/debug/` for a normal debug build. Use `cargo build --release` to produce an optimized release build in `target/release/`.
7. You can add dependencies for your project by editing `Cargo.toml`. When you run `cargo` commands, it will automatically download and compile missing dependencies for you.

#### ▼ *Speaker Notes*

Try to encourage the class participants to install Cargo and use a local editor. It will make their life easier since they will have a normal development environment.



# Welcome to Day 1

This is the first day of Rust Fundamentals. We will cover a lot of ground today:

- Basic Rust syntax: variables, scalar and compound types, enums, structs, references, functions, and methods.
- Types and type inference.
- Control flow constructs: loops, conditionals, and so on.
- User-defined types: structs and enums.
- Pattern matching: destructuring enums, structs, and arrays.

## Schedule

Including 10 minute breaks, this session should take about 2 hours and 10 minutes. It contains:

Segment	Duration
Welcome	5 minutes
Hello, World	15 minutes
Types and Values	40 minutes
Control Flow Basics	45 minutes

### ▼ *Speaker Notes*

This slide should take about 5 minutes.

Please remind the students that:

- They should ask questions when they get them, don't save them to the end.
- The class is meant to be interactive and discussions are very much encouraged!
  - As an instructor, you should try to keep the discussions relevant, i.e., keep the discussions related to how Rust does things vs some other language. It can be hard to find the right balance, but err on the side of allowing discussions since they engage people much more than one-way communication.
- The questions will likely mean that we talk about things ahead of the slides.
  - This is perfectly okay! Repetition is an important part of learning. Remember that the slides are just a support and you are free to skip them as you like.

The idea for the first day is to show the “basic” things in Rust that should have immediate parallels in other languages. The more advanced parts of Rust come on the subsequent days.

If you're teaching this in a classroom, this is a good place to go over the schedule. Note that there is an exercise at the end of each segment, followed by a break. Plan to cover the exercise solution after the break. The times listed here are a suggestion in order to keep the course on schedule. Feel free to be flexible and adjust as necessary!

# Hello, World

This segment should take about 15 minutes. It contains:

Slide	Duration
What is Rust?	10 minutes
Benefits of Rust	3 minutes
Playground	2 minutes

# What is Rust?

Rust is a new programming language which had its [1.0 release in 2015](#):

- Rust is a statically compiled language in a similar role as C++
  - `rustc` uses LLVM as its backend.
- Rust supports many [platforms and architectures](#):
  - x86, ARM, WebAssembly, ...
  - Linux, Mac, Windows, ...
- Rust is used for a wide range of devices:
  - firmware and boot loaders,
  - smart displays,
  - mobile phones,
  - desktops,
  - servers.

## ▼ *Speaker Notes*

This slide should take about 10 minutes.

Rust fits in the same area as C++:

- High flexibility.
- High level of control.
- Can be scaled down to very constrained devices such as microcontrollers.
- Has no runtime or garbage collection.
- Focuses on reliability and safety without sacrificing performance.

# Benefits of Rust

Some unique selling points of Rust:

- *Compile time memory safety* - whole classes of memory bugs are prevented at compile time
  - No uninitialized variables.
  - No double-frees.
  - No use-after-free.
  - No `NULL` pointers.
  - No forgotten locked mutexes.
  - No data races between threads.
  - No iterator invalidation.
- *No undefined runtime behavior* - what a Rust statement does is never left unspecified
  - Array access is bounds checked.
  - Integer overflow is defined (panic or wrap-around).
- *Modern language features* - as expressive and ergonomic as higher-level languages
  - Enums and pattern matching.
  - Generics.
  - No overhead FFI.
  - Zero-cost abstractions.
  - Great compiler errors.
  - Built-in dependency manager.
  - Built-in support for testing.
  - Excellent Language Server Protocol support.

## ▼ *Speaker Notes*

This slide should take about 3 minutes.

Do not spend much time here. All of these points will be covered in more depth later.

Make sure to ask the class which languages they have experience with. Depending on the answer you can highlight different features of Rust:

- Experience with C or C++: Rust eliminates a whole class of *runtime errors* via the borrow checker. You get performance like in C and C++, but you don't have the memory unsafety issues. In addition, you get a modern language with constructs like pattern matching and built-in dependency management.

- Experience with Java, Go, Python, JavaScript...: You get the same memory safety as in those languages, plus a similar high-level language feeling. In addition you get fast and predictable performance like C and C++ (no garbage collector) as well as access to low-level hardware (should you need it).

# Playground

The [Rust Playground](#) provides an easy way to run short Rust programs, and is the basis for the examples and exercises in this course. Try running the “hello-world” program it starts with. It comes with a few handy features:

- Under “Tools”, use the `rustfmt` option to format your code in the “standard” way.
- Rust has two main “profiles” for generating code: Debug (extra runtime checks, less optimization) and Release (fewer runtime checks, lots of optimization). These are accessible under “Debug” at the top.
- If you’re interested, use “ASM” under “...” to see the generated assembly code.

## ▼ *Speaker Notes*

This slide should take about 2 minutes.

As students head into the break, encourage them to open up the playground and experiment a little. Encourage them to keep the tab open and try things out during the rest of the course. This is particularly helpful for advanced students who want to know more about Rust’s optimizations or generated assembly.

# Types and Values

This segment should take about 40 minutes. It contains:

Slide	Duration
Hello, World	5 minutes
Variables	5 minutes
Values	5 minutes
Arithmetic	3 minutes
Type Inference	3 minutes
Exercise: Fibonacci	15 minutes



# Hello, World

Let us jump into the simplest possible Rust program, a classic Hello World program:

```
1 fn main() {  
2     println!("Hello 🌍!");  
3 }
```

What you see:

- Functions are introduced with `fn`.
- The `main` function is the entry point of the program.
- Blocks are delimited by curly braces like in C and C++.
- Statements end with `;`.
- Rust has hygienic macros, `println!` is an example of this.
- Rust strings are UTF-8 encoded and can contain any Unicode character.

## ▼ *Speaker Notes*

This slide should take about 5 minutes.

This slide tries to make the students comfortable with Rust code. They will see a ton of it over the next four days so we start small with something familiar.

Key points:

- Rust is very much like other languages in the C/C++/Java tradition. It is imperative and it doesn't try to reinvent things unless absolutely necessary.
- Rust is modern with full support for things like Unicode.
- Rust uses macros for situations where you want to have a variable number of arguments (no function [overloading](#)).
- Macros being 'hygienic' means they don't accidentally capture identifiers from the scope they are used in. Rust macros are actually only [partially hygienic](#).
- Rust is multi-paradigm. For example, it has powerful [object-oriented programming features](#), and, while it is not a functional language, it includes a range of [functional concepts](#).

# Variables

Rust provides type safety via static typing. Variable bindings are made with `let` :

```
1 fn main() {
2     let x: i32 = 10;
3     println!("x: {x}");
4     // x = 20;
5     // println!("x: {x}");
6 }
```

## ▼ *Speaker Notes*

This slide should take about 5 minutes.

- Uncomment the `x = 20` to demonstrate that variables are immutable by default. Add the `mut` keyword to allow changes.
- Warnings are enabled for this slide, such as for unused variables or unnecessary `mut` . These are omitted in most slides to avoid distracting warnings. Try removing the mutation but leaving the `mut` keyword in place.
- The `i32` here is the type of the variable. This must be known at compile time, but type inference (covered later) allows the programmer to omit it in many cases.

# Values

Here are some basic built-in types, and the syntax for literal values of each type.

	Types	Literals
Signed integers	<code>i8</code> , <code>i16</code> , <code>i32</code> , <code>i64</code> , <code>i128</code> , <code>isize</code>	<code>-10</code> , <code>0</code> , <code>1_000</code> , <code>123_i64</code>
Unsigned integers	<code>u8</code> , <code>u16</code> , <code>u32</code> , <code>u64</code> , <code>u128</code> , <code>usize</code>	<code>0</code> , <code>123</code> , <code>10_u16</code>
Floating point numbers	<code>f32</code> , <code>f64</code>	<code>3.14</code> , <code>-10.0e20</code> , <code>2_f32</code>
Unicode scalar values	<code>char</code>	<code>'a'</code> , <code>'α'</code> , <code>'∞'</code>
Booleans	<code>bool</code>	<code>true</code> , <code>false</code>

The types have widths as follows:

- `iN`, `uN`, and `fN` are  $N$  bits wide,
- `isize` and `usize` are the width of a pointer,
- `char` is 32 bits wide,
- `bool` is 8 bits wide.

## ▼ Speaker Notes

This slide should take about 5 minutes.

There are a few syntaxes which are not shown above:

- All underscores in numbers can be left out, they are for legibility only. So `1_000` can be written as `1000` (or `10_00`), and `123_i64` can be written as `123i64`.

# Arithmetic

```
1 fn interproduct(a: i32, b: i32, c: i32) -> i32 {
2     return a * b + b * c + c * a;
3 }
4
5 fn main() {
6     println!("result: {}", interproduct(120, 100, 248));
7 }
```

## ▼ Speaker Notes

This slide should take about 3 minutes.

This is the first time we've seen a function other than `main`, but the meaning should be clear: it takes three integers, and returns an integer. Functions will be covered in more detail later.

Arithmetic is very similar to other languages, with similar precedence.

What about integer overflow? In C and C++ overflow of *signed* integers is actually undefined, and might do unknown things at runtime. In Rust, it's defined.

Change the `i32`'s to `i16` to see an integer overflow, which panics (checked) in a debug build and wraps in a release build. There are other options, such as overflowing, saturating, and carrying. These are accessed with method syntax, e.g., `(a * b).saturating_add(b * c).saturating_add(c * a)`.

In fact, the compiler will detect overflow of constant expressions, which is why the example requires a separate function.

# Type Inference

Rust will look at how the variable is *used* to determine the type:

```
1 fn takes_u32(x: u32) {
2     println!("u32: {x}");
3 }
4
5 fn takes_i8(y: i8) {
6     println!("i8: {y}");
7 }
8
9 fn main() {
10    let x = 10;
11    let y = 20;
12
13    takes_u32(x);
14    takes_i8(y);
15    // takes_u32(y);
16 }
```

## ▼ Speaker Notes

This slide should take about 3 minutes.

This slide demonstrates how the Rust compiler infers types based on constraints given by variable declarations and usages.

It is very important to emphasize that variables declared like this are not of some sort of dynamic “any type” that can hold any data. The machine code generated by such declaration is identical to the explicit declaration of a type. The compiler does the job for us and helps us write more concise code.

When nothing constrains the type of an integer literal, Rust defaults to `i32`. This sometimes appears as `{integer}` in error messages. Similarly, floating-point literals default to `f64`.

```
fn main() {
    let x = 3.14;
    let y = 20;
    assert_eq!(x, y);
    // ERROR: no implementation for `{float} == {integer}`
}
```

# Exercise: Fibonacci

The Fibonacci sequence begins with  $[0, 1]$ . For  $n > 1$ , the  $n$ 'th Fibonacci number is calculated recursively as the sum of the  $n-1$ 'th and  $n-2$ 'th Fibonacci numbers.

Write a function `fib(n)` that calculates the  $n$ 'th Fibonacci number. When will this function panic?

```
1 fn fib(n: u32) -> u32 {
2     if n < 2 {
3         // The base case.
4         return todo!("Implement this");
5     } else {
6         // The recursive case.
7         return todo!("Implement this");
8     }
9 }
10
11 fn main() {
12     let n = 20;
13     println!("fib({n}) = {}", fib(n));
14 }
```

# Solution

```
1 fn fib(n: u32) -> u32 {
2     if n < 2 {
3         return n;
4     } else {
5         return fib(n - 1) + fib(n - 2);
6     }
7 }
8
9 fn main() {
10     let n = 20;
11     println!("fib({n}) = {}", fib(n));
12 }
```

# Control Flow Basics

This segment should take about 45 minutes. It contains:

Slide	Duration
Blocks and Scopes	5 minutes
if Expressions	4 minutes
match Expressions	5 minutes
Loops	5 minutes
break and continue	4 minutes
Functions	3 minutes
Macros	2 minutes
Exercise: Collatz Sequence	15 minutes

## ▼ *Speaker Notes*

- We will now cover the many kinds of flow control found in Rust.
- Most of this will be very familiar to what you have seen in other programming languages.



# Blocks and Scopes

A block in Rust contains a sequence of expressions, enclosed by braces `{}`. Each block has a value and a type, which are those of the last expression of the block:

```
1 fn main() {
2     let z = 13;
3     let x = {
4         let y = 10;
5         dbg!(y);
6         z - y
7     };
8     dbg!(x);
9     // dbg!(y);
10 }
```

If the last expression ends with `;`, then the resulting value and type is `()`.

A variable's scope is limited to the enclosing block.

## ▼ *Speaker Notes*

This slide should take about 5 minutes.

- You can explain that `dbg!` is a Rust macro that prints and returns the value of a given expression for quick and dirty debugging.
- You can show how the value of the block changes by changing the last line in the block. For instance, adding/removing a semicolon or using a `return`.
- Demonstrate that attempting to access `y` outside of its scope won't compile.
- Values are effectively "deallocated" when they go out of their scope, even if their data on the stack is still there.

# if expressions

You use `if expressions` exactly like `if` statements in other languages:

```
1 fn main() {
2     let x = 10;
3     if x == 0 {
4         println!("zero!");
5     } else if x < 100 {
6         println!("biggish");
7     } else {
8         println!("huge");
9     }
10 }
```

In addition, you can use `if` as an expression. The last expression of each block becomes the value of the `if` expression:

```
1 fn main() {
2     let x = 10;
3     let size = if x < 20 { "small" } else { "large" };
4     println!("number size: {}", size);
5 }
```

## ▼ Speaker Notes

This slide should take about 4 minutes.

Because `if` is an expression and must have a particular type, both of its branch blocks must have the same type. Show what happens if you add `;` after `"small"` in the second example.

An `if` expression should be used in the same way as the other expressions. For example, when it is used in a `let` statement, the statement must be terminated with a `;` as well. Remove the `;` before `println!` to see the compiler error.

# match Expressions

`match` can be used to check a value against one or more options:

```
1 fn main() {
2     let val = 1;
3     match val {
4         1 => println!("one"),
5         10 => println!("ten"),
6         100 => println!("one hundred"),
7         _ => {
8             println!("something else");
9         }
10    }
11 }
```

Like `if` expressions, `match` can also return a value;

```
1 fn main() {
2     let flag = true;
3     let val = match flag {
4         true => 1,
5         false => 0,
6     };
7     println!("The value of {flag} is {val}");
8 }
```

## ▼ Speaker Notes

This slide should take about 5 minutes.

- `match` arms are evaluated from top to bottom, and the first one that matches has its corresponding body executed.
- There is no fall-through between cases the way that `switch` works in other languages.
- The body of a `match` arm can be a single expression or a block. Technically this is the same thing, since blocks are also expressions, but students may not fully understand that symmetry at this point.
- `match` expressions need to be exhaustive, meaning they either need to cover all possible values or they need to have a default case such as `_`. Exhaustiveness is easiest to demonstrate with enums, but enums haven't been introduced yet. Instead we demonstrate matching on a `bool`, which is the simplest primitive type.
- This slide introduces `match` without talking about pattern matching, giving students a chance to get familiar with the syntax without front-loading too much information. We'll

be talking about pattern matching in more detail tomorrow, so try not to go into too much detail here.

## More to Explore

- To further motivate the usage of `match`, you can compare the examples to their equivalents written with `if`. In the second case matching on a `bool` an `if {} else {}` block is pretty similar. But in the first example that checks multiple cases, a `match` expression can be more concise than `if {} else if {} else if {} else`.
- `match` also supports match guards, which allow you to add an arbitrary logical condition that will get evaluated to determine if the match arm should be taken. However talking about match guards requires explaining about pattern matching, which we're trying to avoid on this slide.

# Loops

There are three looping keywords in Rust: `while`, `loop`, and `for`:

## `while`

The `while` keyword works much like in other languages, executing the loop body as long as the condition is true.

```
1 fn main() {
2     let mut x = 200;
3     while x >= 10 {
4         x = x / 2;
5     }
6     dbg!(x);
7 }
```

# for

The `for` loop iterates over ranges of values or the items in a collection:

```
1 fn main() {
2     for x in 1..5 {
3         dbg!(x);
4     }
5
6     for elem in [2, 4, 8, 16, 32] {
7         dbg!(elem);
8     }
9 }
```

## ▼ *Speaker Notes*

- Under the hood `for` loops use a concept called “iterators” to handle iterating over different kinds of ranges/collections. Iterators will be discussed in more detail later.
- Note that the first `for` loop only iterates to `4`. Show the `1..=5` syntax for an inclusive range.

# loop

The `loop` statement just loops forever, until a `break`.

```
1 fn main() {
2     let mut i = 0;
3     loop {
4         i += 1;
5         dbg!(i);
6         if i > 100 {
7             break;
8         }
9     }
10 }
```

## ▼ Speaker Notes

- The `loop` statement works like a `while true` loop. Use it for things like servers which will serve connections forever.

# break and continue

If you want to immediately start the next iteration use `continue`.

If you want to exit any kind of loop early, use `break`. With `loop`, this can take an optional expression that becomes the value of the `loop` expression.

```
1 fn main() {
2     let mut i = 0;
3     loop {
4         i += 1;
5         if i > 5 {
6             break;
7         }
8         if i % 2 == 0 {
9             continue;
10        }
11        dbg!(i);
12    }
13 }
```

## ▼ Speaker Notes

This slide and its sub-slides should take about 4 minutes.

Note that `loop` is the only looping construct which can return a non-trivial value. This is because it's guaranteed to only return at a `break` statement (unlike `while` and `for` loops, which can also return when the condition fails).



# Labels

Both `continue` and `break` can optionally take a label argument which is used to break out of nested loops:

```
1 fn main() {
2     let s = [[5, 6, 7], [8, 9, 10], [21, 15, 32]];
3     let mut elements_searched = 0;
4     let target_value = 10;
5     'outer: for i in 0..=2 {
6         for j in 0..=2 {
7             elements_searched += 1;
8             if s[i][j] == target_value {
9                 break 'outer;
10            }
11        }
12    }
13    dbg!(elements_searched);
14 }
```

## ▼ Speaker Notes

- Labeled break also works on arbitrary blocks, e.g.

```
'label: {
    break 'label;
    println!("This line gets skipped");
}
```

# Functions

```
1 fn gcd(a: u32, b: u32) -> u32 {
2     if b > 0 {
3         gcd(b, a % b)
4     } else {
5         a
6     }
7 }
8
9 fn main() {
10     dbg!(gcd(143, 52));
11 }
```

## ▼ Speaker Notes

This slide should take about 3 minutes.

- Declaration parameters are followed by a type (the reverse of some programming languages), then a return type.
- The last expression in a function body (or any block) becomes the return value. Simply omit the `;` at the end of the expression. The `return` keyword can be used for early return, but the “bare value” form is idiomatic at the end of a function (refactor `gcd` to use a `return`).
- Some functions have no return value, and return the ‘unit type’, `()`. The compiler will infer this if the return type is omitted.
- Overloading is not supported – each function has a single implementation.
  - Always takes a fixed number of parameters. Default arguments are not supported. Macros can be used to support variadic functions.
  - Always takes a single set of parameter types. These types can be generic, which will be covered later.

# Macros

Macros are expanded into Rust code during compilation, and can take a variable number of arguments. They are distinguished by a `!` at the end. The Rust standard library includes an assortment of useful macros.

- `println!(format, ..)` prints a line to standard output, applying formatting described in `std::fmt`.
- `format!(format, ..)` works just like `println!` but returns the result as a string.
- `dbg!(expression)` logs the value of the expression and returns it.
- `todo!()` marks a bit of code as not-yet-implemented. If executed, it will panic.

```
1 fn factorial(n: u32) -> u32 {
2     let mut product = 1;
3     for i in 1..=n {
4         product *= dbg!(i);
5     }
6     product
7 }
8
9 fn fizzbuzz(n: u32) -> u32 {
10     todo!()
11 }
12
13 fn main() {
14     let n = 4;
15     println!("{n}! = {}", factorial(n));
16 }
```

## ▼ Speaker Notes

This slide should take about 2 minutes.

The takeaway from this section is that these common conveniences exist, and how to use them. Why they are defined as macros, and what they expand to, is not especially critical.

The course does not cover defining macros, but a later section will describe use of derive macros.

## More To Explore

There are a number of other useful macros provided by the standard library. Some other examples you can share with students if they want to know more:

- `assert!` and related macros can be used to add assertions to your code. These are used heavily in writing tests.
- `unreachable!` is used to mark a branch of control flow that should never be hit.
- `eprintln!` allows you to print to stderr.

# Exercise: Collatz Sequence

The [Collatz Sequence](#) is defined as follows, for an arbitrary  $n_1$  greater than zero:

- If  $n_i$  is 1, then the sequence terminates at  $n_i$ .
- If  $n_i$  is even, then  $n_{i+1} = n_i / 2$ .
- If  $n_i$  is odd, then  $n_{i+1} = 3 * n_i + 1$ .

For example, beginning with  $n_1 = 3$ :

- 3 is odd, so  $n_2 = 3 * 3 + 1 = 10$ ;
- 10 is even, so  $n_3 = 10 / 2 = 5$ ;
- 5 is odd, so  $n_4 = 3 * 5 + 1 = 16$ ;
- 16 is even, so  $n_5 = 16 / 2 = 8$ ;
- 8 is even, so  $n_6 = 8 / 2 = 4$ ;
- 4 is even, so  $n_7 = 4 / 2 = 2$ ;
- 2 is even, so  $n_8 = 1$ ; and
- the sequence terminates.

Write a function to calculate the length of the collatz sequence for a given initial  $n$ .

```
1  /// Determine the length of the collatz sequence beginning at `n`.
2  fn collatz_length(mut n: i32) -> u32 {
3      todo!("Implement this")
4  }
5
6  fn main() {
7      println!("Length: {}", collatz_length(11)); // should be 15
8  }
```

# Solution

```
1 /// Determine the length of the collatz sequence beginning at `n`.
2 fn collatz_length(mut n: i32) -> u32 {
3     let mut len = 1;
4     while n > 1 {
5         n = if n % 2 == 0 { n / 2 } else { 3 * n + 1 };
6         len += 1;
7     }
8     len
9 }
10
11 fn main() {
12     println!("Length: {}", collatz_length(11)); // should be 15
13 }
```

# Welcome Back

Including 10 minute breaks, this session should take about 2 hours and 45 minutes. It contains:

Segment	Duration
Tuples and Arrays	35 minutes
References	55 minutes
User-Defined Types	1 hour

# Tuples and Arrays

This segment should take about 35 minutes. It contains:

Slide	Duration
Arrays	5 minutes
Tuples	5 minutes
Array Iteration	3 minutes
Patterns and Destructuring	5 minutes
Exercise: Nested Arrays	15 minutes

## ▼ *Speaker Notes*

- We have seen how primitive types work in Rust. Now it's time for you to start building new composite types.



# Arrays

```
1 fn main() {  
2     let mut a: [i8; 5] = [5, 4, 3, 2, 1];  
3     a[2] = 0;  
4     println!("a: {a:?}");  
5 }
```

## ▼ Speaker Notes

This slide should take about 5 minutes.

- Arrays can also be initialized using the shorthand syntax, e.g. `[0; 1024]`. This can be useful when you want to initialize all elements to the same value, or if you have a large array that would be hard to initialize manually.
- A value of the array type `[T; N]` holds `N` (a compile-time constant) elements of the same type `T`. Note that the length of the array is *part of its type*, which means that `[u8; 3]` and `[u8; 4]` are considered two different types. Slices, which have a size determined at runtime, are covered later.
- Try accessing an out-of-bounds array element. Array accesses are checked at runtime. Rust can usually optimize these checks away, and they can be avoided using `unsafe Rust`.
- We can use literals to assign values to arrays.
- The `println!` macro asks for the debug implementation with the `?` format parameter: `{}` gives the default output, `{:?}` gives the debug output. Types such as integers and strings implement the default output, but arrays only implement the debug output. This means that we must use debug output here.
- Adding `#`, eg `{a:#?}`, invokes a “pretty printing” format, which can be easier to read.

# Tuples

```
1 fn main() {  
2     let t: (i8, bool) = (7, true);  
3     dbg!(t.0);  
4     dbg!(t.1);  
5 }
```

## ▼ Speaker Notes

This slide should take about 5 minutes.

- Like arrays, tuples have a fixed length.
- Tuples group together values of different types into a compound type.
- Fields of a tuple can be accessed by the period and the index of the value, e.g. `t.0`, `t.1`.
- The empty tuple `()` is referred to as the “unit type” and signifies absence of a return value, akin to `void` in other languages.

# Array Iteration

The `for` statement supports iterating over arrays (but not tuples).

```
1 fn main() {
2     let primes = [2, 3, 5, 7, 11, 13, 17, 19];
3     for prime in primes {
4         for i in 2..prime {
5             assert_ne!(prime % i, 0);
6         }
7     }
8 }
```

## ▼ *Speaker Notes*

This slide should take about 3 minutes.

This functionality uses the `IntoIterator` trait, but we haven't covered that yet.

The `assert_ne!` macro is new here. There are also `assert_eq!` and `assert!` macros. These are always checked, while debug-only variants like `debug_assert!` compile to nothing in release builds.

# Patterns and Destructuring

Rust supports using pattern matching to destructure a larger value like a tuple into its constituent parts:

```
1 fn check_order(tuple: (i32, i32, i32)) -> bool {
2     let (left, middle, right) = tuple;
3     left < middle && middle < right
4 }
5
6 fn main() {
7     let tuple = (1, 5, 3);
8     println!(
9         "{tuple:?}: {}",
10        if check_order(tuple) { "ordered" } else { "unordered" }
11    );
12 }
```

## ▼ Speaker Notes

This slide should take about 5 minutes.

- The patterns used here are “irrefutable”, meaning that the compiler can statically verify that the value on the right of `=` has the same structure as the pattern.
- A variable name is an irrefutable pattern that always matches any value, hence why we can also use `let` to declare a single variable.
- Rust also supports using patterns in conditionals, allowing for equality comparison and destructuring to happen at the same time. This form of pattern matching will be discussed in more detail later.
- Edit the examples above to show the compiler error when the pattern doesn’t match the value being matched on.

# Exercise: Nested Arrays

Arrays can contain other arrays:

```
1 let array = [[1, 2, 3], [4, 5, 6], [7, 8, 9]];
```

What is the type of this variable?

Use an array such as the above to write a function `transpose` which will transpose a matrix (turn rows into columns):

$$\text{transpose} \left( \begin{bmatrix} 1 & 2 & 3 \\ 4 & 5 & 6 \\ 7 & 8 & 9 \end{bmatrix} \right) == \begin{bmatrix} 1 & 4 & 7 \\ 2 & 5 & 8 \\ 3 & 6 & 9 \end{bmatrix}$$

Copy the code below to <https://play.rust-lang.org/> and implement the function. This function only operates on 3x3 matrices.

```
1 fn transpose(matrix: [[i32; 3]; 3]) -> [[i32; 3]; 3] {
2     todo!()
3 }
4
5 fn main() {
6     let matrix = [
7         [101, 102, 103], // <-- the comment makes rustfmt add a newline
8         [201, 202, 203],
9         [301, 302, 303],
10    ];
11
12    dbg!(matrix);
13    let transposed = transpose(matrix);
14    dbg!(transposed);
15 }
```

# Solution

```
1 fn transpose(matrix: [[i32; 3]; 3]) -> [[i32; 3]; 3] {
2     let mut result = [[0; 3]; 3];
3     for i in 0..3 {
4         for j in 0..3 {
5             result[j][i] = matrix[i][j];
6         }
7     }
8     result
9 }
10
11 fn main() {
12     let matrix = [
13         [101, 102, 103], // <-- the comment makes rustfmt add a newline
14         [201, 202, 203],
15         [301, 302, 303],
16     ];
17
18     dbg!(matrix);
19     let transposed = transpose(matrix);
20     dbg!(transposed);
21 }
```

# References

This segment should take about 55 minutes. It contains:

<b>Slide</b>	<b>Duration</b>
Shared References	10 minutes
Exclusive References	5 minutes
Slices	10 minutes
Strings	10 minutes
Reference Validity	3 minutes
Exercise: Geometry	20 minutes

# Shared References

A reference provides a way to access another value without taking ownership of the value, and is also called “borrowing”. Shared references are read-only, and the referenced data cannot change.

```
1 fn main() {
2     let a = 'A';
3     let b = 'B';
4
5     let mut r: &char = &a;
6     dbg!(*r);
7
8     r = &b;
9     dbg!(*r);
10 }
```

A shared reference to a type  $T$  has type  $\&T$ . A reference value is made with the `&` operator. The `*` operator “dereferences” a reference, yielding its value.

## ▼ Speaker Notes

This slide should take about 7 minutes.

- References can never be null in Rust, so null checking is not necessary.
- A reference is said to “borrow” the value it refers to, and this is a good model for students not familiar with pointers: code can use the reference to access the value, but is still “owned” by the original variable. The course will get into more detail on ownership in day 3.
- References are implemented as pointers, and a key advantage is that they can be much smaller than the thing they point to. Students familiar with C or C++ will recognize references as pointers. Later parts of the course will cover how Rust prevents the memory-safety bugs that come from using raw pointers.
- Rust does not automatically create references for you - the `&` is always required.
- Rust will auto-dereference in some cases, in particular when invoking methods (try `r.is_ascii()`). There is no need for an `->` operator like in C++.
- In this example, `r` is mutable so that it can be reassigned (`r = &b`). Note that this rebinds `r`, so that it refers to something else. This is different from C++, where assignment to a reference changes the referenced value.



- A shared reference does not allow modifying the value it refers to, even if that value was mutable. Try `*r = 'X'` .
- Rust is tracking the lifetimes of all references to ensure they live long enough. Dangling references cannot occur in safe Rust.
- We will talk more about borrowing and preventing dangling references when we get to ownership.

# Exclusive References

Exclusive references, also known as mutable references, allow changing the value they refer to. They have type `&mut T`.

```
1 fn main() {
2     let mut point = (1, 2);
3     let x_coord = &mut point.0;
4     *x_coord = 20;
5     println!("point: {point:?}");
6 }
```

## ▼ Speaker Notes

This slide should take about 5 minutes.

Key points:

- “Exclusive” means that only this reference can be used to access the value. No other references (shared or exclusive) can exist at the same time, and the referenced value cannot be accessed while the exclusive reference exists. Try making an `&point.0` or changing `point.0` while `x_coord` is alive.
- Be sure to note the difference between `let mut x_coord: &i32` and `let x_coord: &mut i32`. The first one represents a shared reference which can be bound to different values, while the second represents an exclusive reference to a mutable value.

# Slices

A slice gives you a view into a larger collection:

```
1 fn main() {
2     let a: [i32; 6] = [10, 20, 30, 40, 50, 60];
3     println!("a: {a:?}");
4
5     let s: &[i32] = &a[2..4];
6
7     println!("s: {s:?}");
8 }
```

- Slices borrow data from the sliced type.

## ▼ Speaker Notes

This slide should take about 7 minutes.

- We create a slice by borrowing `a` and specifying the starting and ending indexes in brackets.
- If the slice starts at index 0, Rust's range syntax allows us to drop the starting index, meaning that `&a[0..a.len()]` and `&a[..a.len()]` are identical.
- The same is true for the last index, so `&a[2..a.len()]` and `&a[2..]` are identical.
- To easily create a slice of the full array, we can therefore use `&a[..]`.
- `s` is a reference to a slice of `i32` `s`. Notice that the type of `s` (`&[i32]`) no longer mentions the array length. This allows us to perform computation on slices of different sizes.
- Slices always borrow from another object. In this example, `a` has to remain 'alive' (in scope) for at least as long as our slice.
- You can't "grow" a slice once it's created:
  - You can't append elements of the slice, since it doesn't own the backing buffer.
  - You can't grow a slice to point to a larger section of the backing buffer. The slice loses information about the underlying buffer and so you can't know how larger the slice can be grown.
  - To get a larger slice you have to back to the original buffer and create a larger slice from there.

# Strings

We can now understand the two string types in Rust:

- `&str` is a slice of UTF-8 encoded bytes, similar to `&[u8]` .
- `String` is an owned buffer of UTF-8 encoded bytes, similar to `Vec<T>` .

```

1 fn main() {
2     let s1: &str = "World";
3     println!("s1: {s1}");
4
5     let mut s2: String = String::from("Hello ");
6     println!("s2: {s2}");
7
8     s2.push_str(s1);
9     println!("s2: {s2}");
10
11    let s3: &str = &s2[2..9];
12    println!("s3: {s3}");
13 }
```

## ▼ Speaker Notes

This slide should take about 10 minutes.

- `&str` introduces a string slice, which is an immutable reference to UTF-8 encoded string data stored in a block of memory. String literals ( `"Hello"` ), are stored in the program's binary.
- Rust's `String` type is a wrapper around a vector of bytes. As with a `Vec<T>` , it is owned.
- As with many other types `String::from()` creates a string from a string literal; `String::new()` creates a new empty string, to which string data can be added using the `push()` and `push_str()` methods.
- The `format!()` macro is a convenient way to generate an owned string from dynamic values. It accepts the same format specification as `println!()` .
- You can borrow `&str` slices from `String` via `&` and optionally range selection. If you select a byte range that is not aligned to character boundaries, the expression will panic. The `chars` iterator iterates over characters and is preferred over trying to get character boundaries right.
- For C++ programmers: think of `&str` as `std::string_view` from C++, but the one that always points to a valid string in memory. Rust `String` is a rough equivalent of

`std::string` from C++ (main difference: it can only contain UTF-8 encoded bytes and will never use a small-string optimization).

- Byte strings literals allow you to create a `&[u8]` value directly:

```
1 fn main() {
2     println!("{:?}", b"abc");
3     println!("{:?}", &[97, 98, 99]);
4 }
```

- Raw strings allow you to create a `&str` value with escapes disabled: `r"\n" == "\\n"`. You can embed double-quotes by using an equal amount of `#` on either side of the quotes:

```
1 fn main() {
2     println!(r#"<a href="link.html">link</a>"#);
3     println!("<a href=\"link.html\">link</a>");
4 }
```

# Reference Validity

Rust enforces a number of rules for references that make them always safe to use. One rule is that references can never be `null`, making them safe to use without `null` checks. The other rule we'll look at for now is that references can't *outlive* the data they point to.

```
1 fn main() {
2     let x_ref = {
3         let x = 10;
4         &x
5     };
6     dbg!(x_ref);
7 }
```

## ▼ *Speaker Notes*

This slide should take about 3 minutes.

- This slide gets students thinking about references as not simply being pointers, since Rust has different rules for references than other languages.
- We'll look at the rest of Rust's borrowing rules on day 3 when we talk about Rust's ownership system.

## More to Explore

- Rust's equivalent of nullability is the `option` type, which can be used to make any type "nullable" (not just references/pointers). We haven't yet introduced enums or pattern matching, though, so try not to go into too much detail about this here.

# Exercise: Geometry

We will create a few utility functions for 3-dimensional geometry, representing a point as `[f64;3]`. It is up to you to determine the function signatures.

```
1  // Calculate the magnitude of a vector by summing the squares of its coordinates
2  // and taking the square root. Use the `sqrt()` method to calculate the square
3  // root, like `v.sqrt()`.
4
5
6  fn magnitude(...) -> f64 {
7      todo!()
8  }
9
10 // Normalize a vector by calculating its magnitude and dividing all of its
11 // coordinates by that magnitude.
12
13
14 fn normalize(...) {
15     todo!()
16 }
17
18 // Use the following `main` to test your work.
19
20 fn main() {
21     println!("Magnitude of a unit vector: {}", magnitude(&[0.0, 1.0, 0.0]));
22
23     let mut v = [1.0, 2.0, 9.0];
24     println!("Magnitude of {v:?}: {}", magnitude(&v));
25     normalize(&mut v);
26     println!("Magnitude of {v:?} after normalization: {}", magnitude(&v));
27 }
```

# Solution

```
1  /// Calculate the magnitude of the given vector.
2  fn magnitude(vector: &[f64; 3]) -> f64 {
3      let mut mag_squared = 0.0;
4      for coord in vector {
5          mag_squared += coord * coord;
6      }
7      mag_squared.sqrt()
8  }
9
10 /// Change the magnitude of the vector to 1.0 without changing its direction.
11 fn normalize(vector: &mut [f64; 3]) {
12     let mag = magnitude(vector);
13     for item in vector {
14         *item /= mag;
15     }
16 }
17
18 fn main() {
19     println!("Magnitude of a unit vector: {}", magnitude(&[0.0, 1.0, 0.0]));
20
21     let mut v = [1.0, 2.0, 9.0];
22     println!("Magnitude of {v:?}: {}", magnitude(&v));
23     normalize(&mut v);
24     println!("Magnitude of {v:?} after normalization: {}", magnitude(&v));
25 }
```

## ▼ Speaker Notes

- Note that in `normalize` we were able to do `*item /= mag` to modify each element. This is because we're iterating using a mutable reference to an array, which causes the `for` loop to give mutable references to each element.



# User-Defined Types

This segment should take about 1 hour. It contains:

Slide	Duration
Named Structs	10 minutes
Tuple Structs	10 minutes
Enums	5 minutes
Type Aliases	2 minutes
Const	10 minutes
Static	5 minutes
Exercise: Elevator Events	15 minutes

# Named Structs

Like C and C++, Rust has support for custom structs:

```
1 struct Person {
2     name: String,
3     age: u8,
4 }
5
6 fn describe(person: &Person) {
7     println!("{}", is {} years old", person.name, person.age);
8 }
9
10 fn main() {
11     let mut peter = Person {
12         name: String::from("Peter"),
13         age: 27,
14     };
15     describe(&peter);
16
17     peter.age = 28;
18     describe(&peter);
19
20     let name = String::from("Avery");
21     let age = 39;
22     let avery = Person { name, age };
23     describe(&avery);
24 }
```

## ▼ Speaker Notes

This slide should take about 10 minutes.

Key Points:

- Structs work like in C or C++.
  - Like in C++, and unlike in C, no typedef is needed to define a type.
  - Unlike in C++, there is no inheritance between structs.
- This may be a good time to let people know there are different types of structs.
  - Zero-sized structs (e.g. `struct Foo;`) might be used when implementing a trait on some type but don't have any data that you want to store in the value itself.
  - The next slide will introduce Tuple structs, used when the field names are not important.
- If you already have variables with the right names, then you can create the struct using a shorthand.
- Struct fields do not support default values. Default values are specified by implementing the `Default` trait which we will cover later.

## More to Explore

- You can also demonstrate the struct update syntax here:

```
let jackie = Person { name: String::from("Jackie"), ..avery };
```

- It allows us to copy the majority of the fields from the old struct without having to explicitly type it all out. It must always be the last element.
- It is mainly used in combination with the `Default` trait. We will talk about struct update syntax in more detail on the slide on the `Default` trait, so we don't need to talk about it here unless students ask about it.

# Tuple Structs

If the field names are unimportant, you can use a tuple struct:

```

1 struct Point(i32, i32);
2
3 fn main() {
4     let p = Point(17, 23);
5     println!("{}, {}", p.0, p.1);
6 }
```

This is often used for single-field wrappers (called newtypes):

```

1 struct PoundsOfForce(f64);
2 struct Newtons(f64);
3
4 fn compute_thruster_force() -> PoundsOfForce {
5     todo!("Ask a rocket scientist at NASA")
6 }
7
8 fn set_thruster_force(force: Newtons) {
9     // ...
10 }
11
12 fn main() {
13     let force = compute_thruster_force();
14     set_thruster_force(force);
15 }
```

## ▼ Speaker Notes

This slide should take about 10 minutes.

- Newtypes are a great way to encode additional information about the value in a primitive type, for example:
  - The number is measured in some units: `Newtons` in the example above.
  - The value passed some validation when it was created, so you no longer have to validate it again at every use: `PhoneNumber(String)` OR `OddNumber(u32)` .
- Demonstrate how to add a `f64` value to a `Newtons` type by accessing the single field in the newtype.
  - Rust generally doesn't like inexplicit things, like automatic unwrapping or for instance using booleans as integers.
  - Operator overloading is discussed on Day 3 (generics).
- When a tuple struct has zero fields, the `()` can be omitted. The result is a zero-sized type (ZST), of which there is only one value (the name of the type).

- This is common for types that implement some behavior but have no data (imagine a `NullReader` that implements some reader behavior by always returning EOF).
- The example is a subtle reference to the [Mars Climate Orbiter](#) failure.

# Enums

The `enum` keyword allows the creation of a type which has a few different variants:

```

1  #[derive(Debug)]
2  enum Direction {
3      Left,
4      Right,
5  }
6
7  #[derive(Debug)]
8  enum PlayerMove {
9      Pass, // Simple variant
10     Run(Direction), // Tuple variant
11     Teleport { x: u32, y: u32 }, // Struct variant
12 }
13
14 fn main() {
15     let dir = Direction::Left;
16     let player_move: PlayerMove = PlayerMove::Run(dir);
17     println!("On this turn: {player_move:?}");
18 }
```

## ▼ Speaker Notes

This slide should take about 5 minutes.

Key Points:

- Enumerations allow you to collect a set of values under one type.
- `Direction` is a type with variants. There are two values of `Direction: Direction::Left` and `Direction::Right`.
- `PlayerMove` is a type with three variants. In addition to the payloads, Rust will store a discriminant so that it knows at runtime which variant is in a `PlayerMove` value.
- This might be a good time to compare structs and enums:
  - In both, you can have a simple version without fields (unit struct) or one with different types of fields (variant payloads).
  - You could even implement the different variants of an enum with separate structs but then they wouldn't be the same type as they would if they were all defined in an enum.
- Rust uses minimal space to store the discriminant.
  - If necessary, it stores an integer of the smallest required size
  - If the allowed variant values do not cover all bit patterns, it will use invalid bit patterns to encode the discriminant (the "niche optimization"). For example,

`Option<u8>` stores either a pointer to an integer or `NULL` for the `None` variant.

- o You can control the discriminant if needed (e.g., for compatibility with C):

```

1  #[repr(u32)]
2  enum Bar {
3      A, // 0
4      B = 10000,
5      C, // 10001
6  }
7
8  fn main() {
9      println!("A: {}", Bar::A as u32);
10     println!("B: {}", Bar::B as u32);
11     println!("C: {}", Bar::C as u32);
12 }

```

Without `repr`, the discriminant type takes 2 bytes, because 10001 fits 2 bytes.

## More to Explore

Rust has several optimizations it can employ to make enums take up less space.

- Null pointer optimization: For [some types](#), Rust guarantees that `size_of::()` equals `size_of::<Option<T>>()`.

Example code if you want to show how the bitwise representation *may* look like in practice. It's important to note that the compiler provides no guarantees regarding this representation, therefore this is totally unsafe.

```
1 use std::mem::transmute;
2
3 macro_rules! dbg_bits {
4     ($e:expr, $bit_type:ty) => {
5         println!("- {}: {:#x}", stringify!($e), transmute::<_, $bit_type>
6     );
7     }
8
9 fn main() {
10     unsafe {
11         println!("bool:");
12         dbg_bits!(false, u8);
13         dbg_bits!(true, u8);
14
15         println!("Option<bool>:");
16         dbg_bits!(None::<bool>, u8);
17         dbg_bits!(Some(false), u8);
18         dbg_bits!(Some(true), u8);
19
20         println!("Option<Option<bool>>:");
21         dbg_bits!(Some(Some(false)), u8);
22         dbg_bits!(Some(Some(true)), u8);
23         dbg_bits!(Some(None::<bool>), u8);
24         dbg_bits!(None::<Option<bool>>, u8);
25
26         println!("Option<&i32>:");
27         dbg_bits!(None::<&i32>, usize);
28         dbg_bits!(Some(&0i32), usize);
29     }
30 }
```



# Type Aliases

A type alias creates a name for another type. The two types can be used interchangeably.

```
1 enum CarryableConcreteItem {
2     Left,
3     Right,
4 }
5
6 type Item = CarryableConcreteItem;
7
8 // Aliases are more useful with long, complex types:
9 use std::cell::RefCell;
10 use std::sync::{Arc, RwLock};
11 type PlayerInventory = RwLock<Vec<Arc<RefCell<Item>>>>;
```

## ▼ Speaker Notes

This slide should take about 2 minutes.

- A `newtype` is often a better alternative since it creates a distinct type. Prefer `struct InventoryCount(usize) to type InventoryCount = usize`.
- C programmers will recognize this as similar to a `typedef`.

# const

Constants are evaluated at compile time and their values are inlined wherever they are used:

```
1 |const DIGEST_SIZE: usize = 3;
2 |const FILL_VALUE: u8 = calculate_fill_value();
3
4 |const fn calculate_fill_value() -> u8 {
5 |     if DIGEST_SIZE < 10 {
6 |         42
7 |     } else {
8 |         13
9 |     }
10 }
11
12 |fn compute_digest(text: &str) -> [u8; DIGEST_SIZE] {
13 |     let mut digest = [FILL_VALUE; DIGEST_SIZE];
14 |     for (idx, &b) in text.as_bytes().iter().enumerate() {
15 |         digest[idx % DIGEST_SIZE] = digest[idx % DIGEST_SIZE].wrapping_add(b);
16 |     }
17 |     digest
18 | }
19
20 |fn main() {
21 |     let digest = compute_digest("Hello");
22 |     println!("digest: {digest:?}");
23 | }
```

According to the [Rust RFC Book](#) these are inlined upon use.

Only functions marked `const` can be called at compile time to generate `const` values. `const` functions can however be called at runtime.

## ▼ *Speaker Notes*

This slide should take about 10 minutes.

- Mention that `const` behaves semantically similar to C++'s `constexpr`

# static

Static variables will live during the whole execution of the program, and therefore will not move:

```
1 static BANNER: &str = "Welcome to RustOS 3.14";
2
3 fn main() {
4     println!("{BANNER}");
5 }
```

As noted in the [Rust RFC Book](#), these are not inlined upon use and have an actual associated memory location. This is useful for unsafe and embedded code, and the variable lives through the entirety of the program execution. When a globally-scoped value does not have a reason to need object identity, `const` is generally preferred.

## ▼ Speaker Notes

This slide should take about 5 minutes.

- `static` is similar to mutable global variables in C++.
- `static` provides object identity: an address in memory and state as required by types with interior mutability such as `Mutex<T>`.

## More to Explore

Because `static` variables are accessible from any thread, they must be `Sync`. Interior mutability is possible through a `Mutex`, `atomic` or similar.

It is common to use `onceLock` in a `static` as a way to support initialization on first use. `onceCell` is not `sync` and thus cannot be used in this context.

Thread-local data can be created with the macro `std::thread_local`.

# Exercise: Elevator Events

We will create a data structure to represent an event in an elevator control system. It is up to you to define the types and functions to construct various events. Use `#[derive(Debug)]` to allow the types to be formatted with `{:?}`.

This exercise only requires creating and populating data structures so that `main` runs without errors. The next part of the course will cover getting data out of these structures.

```
1  #![allow(dead_code)]
2
3  #[derive(Debug)]
4  /// An event in the elevator system that the controller must react to.
5  enum Event {
6      // TODO: add required variants
7  }
8
9  /// A direction of travel.
10 #[derive(Debug)]
11 enum Direction {
12     Up,
13     Down,
14 }
15
16 /// The car has arrived on the given floor.
17 fn car_arrived(floor: i32) -> Event {
18     todo!()
19 }
20
21 /// The car doors have opened.
22 fn car_door_opened() -> Event {
23     todo!()
24 }
25
26 /// The car doors have closed.
27 fn car_door_closed() -> Event {
28     todo!()
29 }
30
31 /// A directional button was pressed in an elevator lobby on the given floor.
32 fn lobby_call_button_pressed(floor: i32, dir: Direction) -> Event {
33     todo!()
34 }
35
36 /// A floor button was pressed in the elevator car.
37 fn car_floor_button_pressed(floor: i32) -> Event {
38     todo!()
39 }
40
41 fn main() {
42     println!(
43         "A ground floor passenger has pressed the up button: {:?}",
44         lobby_call_button_pressed(0, Direction::Up)
45     );
46     println!("The car has arrived on the ground floor: {:?}", car_arrived(0));
47     println!("The car door opened: {:?}", car_door_opened());
48     println!(
49         "A passenger has pressed the 3rd floor button: {:?}",
50         car_floor_button_pressed(3)
51     );
52     println!("The car door closed: {:?}", car_door_closed());
53     println!("The car has arrived on the 3rd floor: {:?}", car_arrived(3));
54 }
```

### ▼ *Speaker Notes*

This slide and its sub-slides should take about 15 minutes.

- If students ask about `#![allow(dead_code)]` at the top of the exercise, it's necessary because the only thing we do with the `Event` type is print it out. Due to a nuance of how the compiler checks for dead code this causes it to think that the code is unused. They can ignore it for the purpose of this exercise.



# Solution

```
1  #![allow(dead_code)]
2
3  #[derive(Debug)]
4  /// An event in the elevator system that the controller must react to.
5  enum Event {
6      /// A button was pressed.
7      ButtonPressed(Button),
8
9      /// The car has arrived at the given floor.
10     CarArrived(Floor),
11
12     /// The car's doors have opened.
13     CarDoorOpened,
14
15     /// The car's doors have closed.
16     CarDoorClosed,
17 }
18
19 /// A floor is represented as an integer.
20 type Floor = i32;
21
22 /// A direction of travel.
23 #[derive(Debug)]
24 enum Direction {
25     Up,
26     Down,
27 }
28
29 /// A user-accessible button.
30 #[derive(Debug)]
31 enum Button {
32     /// A button in the elevator lobby on the given floor.
33     LobbyCall(Direction, Floor),
34
35     /// A floor button within the car.
36     CarFloor(Floor),
37 }
38
39 /// The car has arrived on the given floor.
40 fn car_arrived(floor: i32) -> Event {
41     Event::CarArrived(floor)
42 }
43
44 /// The car doors have opened.
45 fn car_door_opened() -> Event {
46     Event::CarDoorOpened
47 }
48
49 /// The car doors have closed.
50 fn car_door_closed() -> Event {
51     Event::CarDoorClosed
```



```
52 }
53
54 /// A directional button was pressed in an elevator lobby on the given floor.
55 fn lobby_call_button_pressed(floor: i32, dir: Direction) -> Event {
56     Event::ButtonPressed(Button::LobbyCall(dir, floor))
57 }
58
59 /// A floor button was pressed in the elevator car.
60 fn car_floor_button_pressed(floor: i32) -> Event {
61     Event::ButtonPressed(Button::CarFloor(floor))
62 }
63
64 fn main() {
65     println!(
66         "A ground floor passenger has pressed the up button: {:?}",
67         lobby_call_button_pressed(0, Direction::Up)
68     );
69     println!("The car has arrived on the ground floor: {:?}", car_arrived(0));
70     println!("The car door opened: {:?}", car_door_opened());
71     println!(
72         "A passenger has pressed the 3rd floor button: {:?}",
73         car_floor_button_pressed(3)
74     );
75     println!("The car door closed: {:?}", car_door_closed());
76     println!("The car has arrived on the 3rd floor: {:?}", car_arrived(3));
77 }
```

# Welcome to Day 2

Now that we have seen a fair amount of Rust, today will focus on Rust's type system:

- Pattern matching: extracting data from structures.
- Methods: associating functions with types.
- Traits: behaviors shared by multiple types.
- Generics: parameterizing types on other types.
- Standard library types and traits: a tour of Rust's rich standard library.
- Closures: function pointers with data.

## Schedule

Including 10 minute breaks, this session should take about 2 hours and 45 minutes. It contains:

Segment	Duration
Welcome	3 minutes
Pattern Matching	50 minutes
Methods and Traits	45 minutes
Generics	45 minutes

# Pattern Matching

This segment should take about 50 minutes. It contains:

Slide	Duration
Irrefutable Patterns	5 minutes
Matching Values	10 minutes
Destructuring Structs	4 minutes
Destructuring Enums	4 minutes
Let Control Flow	10 minutes
Exercise: Expression Evaluation	15 minutes

# Irrefutable Patterns

In day 1 we briefly saw how patterns can be used to *destructure* compound values. Let's review that and talk about a few other things patterns can express:

```
1 fn takes_tuple(tuple: (char, i32, bool)) {
2     let a = tuple.0;
3     let b = tuple.1;
4     let c = tuple.2;
5
6     // This does the same thing as above.
7     let (a, b, c) = tuple;
8
9     // Ignore the first element, only bind the second and third.
10    let (_, b, c) = tuple;
11
12    // Ignore everything but the last element.
13    let (.., c) = tuple;
14 }
15
16 fn main() {
17     takes_tuple(('a', 777, true));
18 }
```

## ▼ Speaker Notes

This slide should take about 5 minutes.

- All of the demonstrated patterns are *irrefutable*, meaning that they will always match the value on the right hand side.
- Patterns are type-specific, including irrefutable patterns. Try adding or removing an element to the tuple and look at the resulting compiler errors.
- Variable names are patterns that always match and which bind the matched value into a new variable with that name.
- `_` is a pattern that always matches any value, discarding the matched value.
- `..` allows you to ignore multiple values at once.

## More to Explore

- You can also demonstrate more advanced usages of `..`, such as ignoring the middle elements of a tuple.

```
fn takes_tuple(tuple: (char, i32, bool, u8)) {  
    let (first, .., last) = tuple;  
}
```

- All of these patterns work with arrays as well:

```
fn takes_array(array: [u8; 5]) {  
    let [first, .., last] = array;  
}
```

# Matching Values

The `match` keyword lets you match a value against one or more *patterns*. The patterns can be simple values, similarly to `switch` in C and C++, but they can also be used to express more complex conditions:

```

1  #[rustfmt::skip]
2  fn main() {
3      let input = 'x';
4      match input {
5          'q'                => println!("Quitting"),
6          'a' | 's' | 'w' | 'd' => println!("Moving around"),
7          '0'..='9'          => println!("Number input"),
8          key if key.is_lowercase() => println!("Lowercase: {key}"),
9          _                  => println!("Something else"),
10     }
11 }
```

A variable in the pattern ( `key` in this example) will create a binding that can be used within the match arm. We will learn more about this on the next slide.

A match guard causes the arm to match only if the condition is true. If the condition is false the match will continue checking later cases.

## ▼ Speaker Notes

This slide should take about 10 minutes.

Key Points:

- You might point out how some specific characters are being used when in a pattern
  - `|` as an `or`
  - `..` can expand as much as it needs to be
  - `1..=5` represents an inclusive range
  - `_` is a wild card
- Match guards as a separate syntax feature are important and necessary when we wish to concisely express more complex ideas than patterns alone would allow.
- They are not the same as separate `if` expression inside of the match arm. An `if` expression inside of the branch block (after `=>`) happens after the match arm is selected. Failing the `if` condition inside of that block won't result in other arms of the original `match` expression being considered.

- The condition defined in the guard applies to every expression in a pattern with an `|`.

## More To Explore

- Another piece of pattern syntax you can show students is the `@` syntax which binds a part of a pattern to a variable. For example:

```
let opt = Some(123);
match opt {
    outer @ Some(inner) => {
        println!("outer: {outer:?}, inner: {inner}");
    }
    None => {}
}
```

In this example `inner` has the value 123 which it pulled from the `option` via destructuring, `outer` captures the entire `Some(inner)` expression, so it contains the full `option::Some(123)`. This is rarely used but can be useful in more complex patterns.

# Structs

Like tuples, Struct can also be destructured by matching:

```
1 struct Foo {
2     x: (u32, u32),
3     y: u32,
4 }
5
6 #[rustfmt::skip]
7 fn main() {
8     let foo = Foo { x: (1, 2), y: 3 };
9     match foo {
10         Foo { x: (1, b), y } => println!("x.0 = 1, b = {b}, y = {y}"),
11         Foo { y: 2, x: i }   => println!("y = 2, x = {i:?}"),
12         Foo { y, .. }       => println!("y = {y}, other fields were ignored")
13     }
14 }
```

## ▼ Speaker Notes

This slide should take about 4 minutes.

- Change the literal values in `foo` to match with the other patterns.
- Add a new field to `Foo` and make changes to the pattern as needed.

## More to Explore

- Try `match &foo` and check the type of captures. The pattern syntax remains the same, but the captures become shared references. This is [match ergonomics](#) and is often useful with `match self` when implementing methods on an enum.
  - The same effect occurs with `match &mut foo`: the captures become exclusive references.
- The distinction between a capture and a constant expression can be hard to spot. Try changing the `2` in the second arm to a variable, and see that it subtly doesn't work. Change it to a `const` and see it working again.



# Enums

Like tuples, enums can also be destructured by matching:

Patterns can also be used to bind variables to parts of your values. This is how you inspect the structure of your types. Let us start with a simple `enum` type:

```
1 enum Result {
2     Ok(i32),
3     Err(String),
4 }
5
6 fn divide_in_two(n: i32) -> Result {
7     if n % 2 == 0 {
8         Result::Ok(n / 2)
9     } else {
10        Result::Err(format!("cannot divide {n} into two equal parts"))
11    }
12 }
13
14 fn main() {
15     let n = 100;
16     match divide_in_two(n) {
17         Result::Ok(half) => println!("{n} divided in two is {half}"),
18         Result::Err(msg) => println!("sorry, an error happened: {msg}"),
19     }
20 }
```

Here we have used the arms to *destructure* the `Result` value. In the first arm, `half` is bound to the value inside the `ok` variant. In the second arm, `msg` is bound to the error message.

## ▼ Speaker Notes

This slide should take about 4 minutes.

- The `if / else` expression is returning an enum that is later unpacked with a `match`.
- You can try adding a third variant to the enum definition and displaying the errors when running the code. Point out the places where your code is now inexhaustive and how the compiler tries to give you hints.
- The values in the enum variants can only be accessed after being pattern matched.
- Demonstrate what happens when the search is inexhaustive. Note the advantage the Rust compiler provides by confirming when all cases are handled.

# Let Control Flow

Rust has a few control flow constructs which differ from other languages. They are used for pattern matching:

- `if let` expressions
- `while let` expressions
- `let else` expressions

# if let Expressions

The `if let` expression lets you execute different code depending on whether a value matches a pattern:

```
1 use std::time::Duration;
2
3 fn sleep_for(secs: f32) {
4     if let Ok(duration) = Duration::try_from_secs_f32(secs) {
5         std::thread::sleep(duration);
6         println!("slept for {duration:?}");
7     }
8 }
9
10 fn main() {
11     sleep_for(-10.0);
12     sleep_for(0.8);
13 }
```

## ▼ Speaker Notes

- Unlike `match`, `if let` does not have to cover all branches. This can make it more concise than `match`.
- A common usage is handling `Some` values when working with `Option`.
- Unlike `match`, `if let` does not support guard clauses for pattern matching.
- With an `else` clause, this can be used as an expression.

# while let Statements

Like with `if let`, there is a `while let` variant which repeatedly tests a value against a pattern:

```
1 fn main() {
2     let mut name = String::from("Comprehensive Rust 🦀");
3     while let Some(c) = name.pop() {
4         dbg!(c);
5     }
6     // (There are more efficient ways to reverse a string!)
7 }
```

Here `String::pop` returns `Some(c)` until the string is empty, after which it will return `None`. The `while let` lets us keep iterating through all items.

## ▼ Speaker Notes

- Point out that the `while let` loop will keep going as long as the value matches the pattern.
- You could rewrite the `while let` loop as an infinite loop with an `if` statement that breaks when there is no value to unwrap for `name.pop()`. The `while let` provides syntactic sugar for the above scenario.
- This form cannot be used as an expression, because it may have no value if the condition is false.

# let else Statements

For the common case of matching a pattern and returning from the function, use `let else`. The “else” case must diverge ( `return`, `break`, or `panic` - anything but falling off the end of the block).

```
1 fn hex_or_die_trying(maybe_string: Option<String>) -> Result<u32, String> {
2     let s = if let Some(s) = maybe_string {
3         s
4     } else {
5         return Err(String::from("got None"));
6     };
7
8     let first_byte_char = if let Some(first) = s.chars().next() {
9         first
10    } else {
11        return Err(String::from("got empty string"));
12    };
13
14    let digit = if let Some(digit) = first_byte_char.to_digit(16) {
15        digit
16    } else {
17        return Err(String::from("not a hex digit"));
18    };
19
20    Ok(digit)
21 }
22
23 fn main() {
24     println!("result: {:?}", hex_or_die_trying(Some(String::from("foo"))));
25 }
```

## ▼ Speaker Notes

The rewritten version is:

```
fn hex_or_die_trying(maybe_string: Option<String>) -> Result<u32, String> {
    let Some(s) = maybe_string else {
        return Err(String::from("got None"));
    };

    let Some(first_byte_char) = s.chars().next() else {
        return Err(String::from("got empty string"));
    };

    let Some(digit) = first_byte_char.to_digit(16) else {
        return Err(String::from("not a hex digit"));
    };

    Ok(digit)
}
```

## More to Explore

- This early return-based control flow is common in Rust error handling code, where you try to get a value out of a `Result`, returning an error if the `Result` was `Err`.
- If students ask, you can also demonstrate how real error handling code would be written with `?`.

# Exercise: Expression Evaluation

Let's write a simple recursive evaluator for arithmetic expressions.

An example of a small arithmetic expression could be  $10 + 20$ , which evaluates to  $30$ . We can represent the expression as a tree:

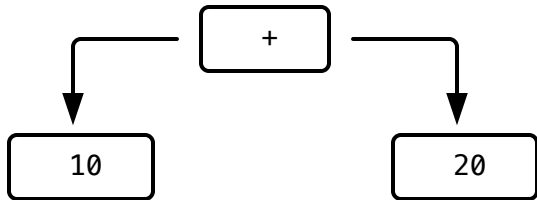

A bigger and more complex expression would be  $(10 * 9) + ((3 - 4) * 5)$ , which evaluates to  $85$ . We represent this as a much bigger tree:

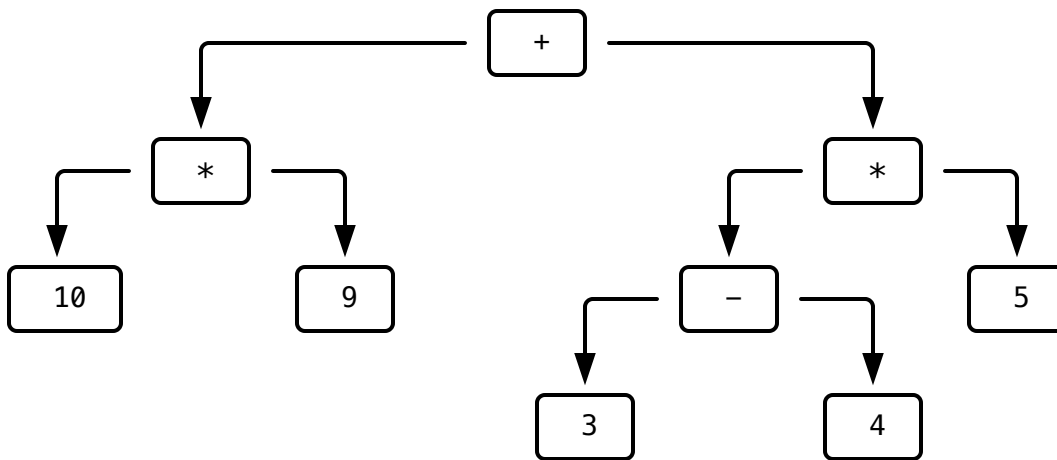

In code, we will represent the tree with two types:

```

/// An operation to perform on two subexpressions.
#[derive(Debug)]
enum Operation {
    Add,
    Sub,
    Mul,
    Div,
}

/// An expression, in tree form.
#[derive(Debug)]
enum Expression {
    /// An operation on two subexpressions.
    Op { op: Operation, left: Box<Expression>, right: Box<Expression> },

    /// A literal value
    Value(i64),
}

```

The `Box` type here is a smart pointer, and will be covered in detail later in the course. An expression can be “boxed” with `Box::new` as seen in the tests. To evaluate a boxed expression, use the deref operator (`*`) to “unbox” it: `eval(*boxed_expr)`.

Copy and paste the code into the Rust playground, and begin implementing `eval`. The final product should pass the tests. It may be helpful to use `todo!()` and get the tests to pass one-by-one. You can also skip a test temporarily with `#[ignore]`:

```

#[test]
#[ignore]
fn test_value() { .. }

```



```

1  /// An operation to perform on two subexpressions.
2  #[derive(Debug)]
3  enum Operation {
4      Add,
5      Sub,
6      Mul,
7      Div,
8  }
9
10 /// An expression, in tree form.
11 #[derive(Debug)]
12 enum Expression {
13     /// An operation on two subexpressions.
14     Op { op: Operation, left: Box<Expression>, right: Box<Expression> },
15
16     /// A literal value
17     Value(i64),
18 }
19
20 fn eval(e: Expression) -> i64 {
21     todo!()
22 }
23
24 #[test]
25 fn test_value() {
26     assert_eq!(eval(Expression::Value(19)), 19);
27 }
28
29 #[test]
30 fn test_sum() {
31     assert_eq!(
32         eval(Expression::Op {
33             op: Operation::Add,
34             left: Box::new(Expression::Value(10)),
35             right: Box::new(Expression::Value(20)),
36         }),
37         30
38     );
39 }
40
41 #[test]
42 fn test_recursion() {
43     let term1 = Expression::Op {
44         op: Operation::Mul,
45         left: Box::new(Expression::Value(10)),
46         right: Box::new(Expression::Value(9)),
47     };
48     let term2 = Expression::Op {
49         op: Operation::Mul,
50         left: Box::new(Expression::Op {
51             op: Operation::Sub,
52             left: Box::new(Expression::Value(3)),
53             right: Box::new(Expression::Value(4)),
54         }),
55         right: Box::new(Expression::Value(5))

```

```

55         right: Box::new(Expression::value(0)),
56     };
57     assert_eq!(
58         eval(Expression::Op {
59             op: Operation::Add,
60             left: Box::new(term1),
61             right: Box::new(term2),
62         }),
63         85
64     );
65 }
66
67 #[test]
68 fn test_zeros() {
69     assert_eq!(
70         eval(Expression::Op {
71             op: Operation::Add,
72             left: Box::new(Expression::Value(0)),
73             right: Box::new(Expression::Value(0))
74         }),
75         0
76     );
77     assert_eq!(
78         eval(Expression::Op {
79             op: Operation::Mul,
80             left: Box::new(Expression::Value(0)),
81             right: Box::new(Expression::Value(0))
82         }),
83         0
84     );
85     assert_eq!(
86         eval(Expression::Op {
87             op: Operation::Sub,
88             left: Box::new(Expression::Value(0)),
89             right: Box::new(Expression::Value(0))
90         }),
91         0
92     );
93 }
94
95 #[test]
96 fn test_div() {
97     assert_eq!(
98         eval(Expression::Op {
99             op: Operation::Div,
100            left: Box::new(Expression::Value(10)),
101            right: Box::new(Expression::Value(2)),
102        }),
103        5
104    )
105 }

```



# Solution

```

1  /// An operation to perform on two subexpressions.
2  #[derive(Debug)]
3  enum Operation {
4      Add,
5      Sub,
6      Mul,
7      Div,
8  }
9
10 /// An expression, in tree form.
11 #[derive(Debug)]
12 enum Expression {
13     /// An operation on two subexpressions.
14     Op { op: Operation, left: Box<Expression>, right: Box<Expression> },
15
16     /// A literal value
17     Value(i64),
18 }
19
20 fn eval(e: Expression) -> i64 {
21     match e {
22         Expression::Op { op, left, right } => {
23             let left = eval(*left);
24             let right = eval(*right);
25             match op {
26                 Operation::Add => left + right,
27                 Operation::Sub => left - right,
28                 Operation::Mul => left * right,
29                 Operation::Div => left / right,
30             }
31         }
32         Expression::Value(v) => v,
33     }
34 }
35
36 #[test]
37 fn test_value() {
38     assert_eq!(eval(Expression::Value(19)), 19);
39 }
40
41 #[test]
42 fn test_sum() {
43     assert_eq!(
44         eval(Expression::Op {
45             op: Operation::Add,
46             left: Box::new(Expression::Value(10)),
47             right: Box::new(Expression::Value(20)),
48         }),
49         30
50     );
51 }

```

```

52
53 #[test]
54 fn test_recursion() {
55     let term1 = Expression::Op {
56         op: Operation::Mul,
57         left: Box::new(Expression::Value(10)),
58         right: Box::new(Expression::Value(9)),
59     };
60     let term2 = Expression::Op {
61         op: Operation::Mul,
62         left: Box::new(Expression::Op {
63             op: Operation::Sub,
64             left: Box::new(Expression::Value(3)),
65             right: Box::new(Expression::Value(4)),
66         }),
67         right: Box::new(Expression::Value(5)),
68     };
69     assert_eq!(
70         eval(Expression::Op {
71             op: Operation::Add,
72             left: Box::new(term1),
73             right: Box::new(term2),
74         }),
75         85
76     );
77 }
78
79 #[test]
80 fn test_zeros() {
81     assert_eq!(
82         eval(Expression::Op {
83             op: Operation::Add,
84             left: Box::new(Expression::Value(0)),
85             right: Box::new(Expression::Value(0))
86         }),
87         0
88     );
89     assert_eq!(
90         eval(Expression::Op {
91             op: Operation::Mul,
92             left: Box::new(Expression::Value(0)),
93             right: Box::new(Expression::Value(0))
94         }),
95         0
96     );
97     assert_eq!(
98         eval(Expression::Op {
99             op: Operation::Sub,
100            left: Box::new(Expression::Value(0)),
101            right: Box::new(Expression::Value(0))
102        }),
103        0
104    );
105 }
106

```

```
100
107 #[test]
108 fn test_div() {
109     assert_eq!(
110         eval(Expression::Op {
111             op: Operation::Div,
112             left: Box::new(Expression::Value(10)),
113             right: Box::new(Expression::Value(2)),
114         }),
115         5
116     )
117 }
```

# Methods and Traits

This segment should take about 45 minutes. It contains:

Slide	Duration
Methods	10 minutes
Traits	15 minutes
Deriving	3 minutes
Exercise: Generic Logger	15 minutes

# Methods

Rust allows you to associate functions with your new types. You do this with an `impl` block:

```

1  #[derive(Debug)]
2  struct CarRace {
3      name: String,
4      laps: Vec<i32>,
5  }
6
7  impl CarRace {
8      // No receiver, a static method
9      fn new(name: &str) -> Self {
10         Self { name: String::from(name), laps: Vec::new() }
11     }
12
13     // Exclusive borrowed read-write access to self
14     fn add_lap(&mut self, lap: i32) {
15         self.laps.push(lap);
16     }
17
18     // Shared and read-only borrowed access to self
19     fn print_laps(&self) {
20         println!("Recorded {} laps for {}:", self.laps.len(), self.name);
21         for (idx, lap) in self.laps.iter().enumerate() {
22             println!("Lap {idx}: {lap} sec");
23         }
24     }
25
26     // Exclusive ownership of self (covered later)
27     fn finish(self) {
28         let total: i32 = self.laps.iter().sum();
29         println!("Race {} is finished, total lap time: {}", self.name, total);
30     }
31 }
32
33 fn main() {
34     let mut race = CarRace::new("Monaco Grand Prix");
35     race.add_lap(70);
36     race.add_lap(68);
37     race.print_laps();
38     race.add_lap(71);
39     race.print_laps();
40     race.finish();
41     // race.add_lap(42);
42 }

```

The `self` arguments specify the “receiver” - the object the method acts on. There are several common receivers for a method:



- `&self` : borrows the object from the caller using a shared and immutable reference. The object can be used again afterwards.
- `&mut self` : borrows the object from the caller using a unique and mutable reference. The object can be used again afterwards.
- `self` : takes ownership of the object and moves it away from the caller. The method becomes the owner of the object. The object will be dropped (deallocated) when the method returns, unless its ownership is explicitly transmitted. Complete ownership does not automatically mean mutability.
- `mut self` : same as above, but the method can mutate the object.
- No receiver: this becomes a static method on the struct. Typically used to create constructors which are called `new` by convention.

### ▼ *Speaker Notes*

This slide should take about 8 minutes.

#### Key Points:

- It can be helpful to introduce methods by comparing them to functions.
  - Methods are called on an instance of a type (such as a struct or enum), the first parameter represents the instance as `self`.
  - Developers may choose to use methods to take advantage of method receiver syntax and to help keep them more organized. By using methods we can keep all the implementation code in one predictable place.
  - Note that methods can also be called like associated functions by explicitly passing the receiver in, e.g. `CarRace::add_lap(&mut race, 20)`.
- Point out the use of the keyword `self`, a method receiver.
  - Show that it is an abbreviated term for `self: self` and perhaps show how the struct name could also be used.
  - Explain that `self` is a type alias for the type the `impl` block is in and can be used elsewhere in the block.
  - Note how `self` is used like other structs and dot notation can be used to refer to individual fields.
  - This might be a good time to demonstrate how the `&self` differs from `self` by trying to run `finish` twice.
  - Beyond variants on `self`, there are also [special wrapper types](#) allowed to be receiver types, such as `Box<Self>`.

# Traits

Rust lets you abstract over types with traits. They're similar to interfaces:

```
1 trait Pet {  
2     /// Return a sentence from this pet.  
3     fn talk(&self) -> String;  
4  
5     /// Print a string to the terminal greeting this pet.  
6     fn greet(&self);  
7 }
```

## ▼ Speaker Notes

This slide and its sub-slides should take about 15 minutes.

- A trait defines a number of methods that types must have in order to implement the trait.
- In the “Generics” segment, next, we will see how to build functionality that is generic over all types implementing a trait.

# Implementing Traits

```
1 trait Pet {
2     fn talk(&self) -> String;
3
4     fn greet(&self) {
5         println!("Oh you're a cutie! What's your name? {}", self.talk());
6     }
7 }
8
9 struct Dog {
10    name: String,
11    age: i8,
12 }
13
14 impl Pet for Dog {
15    fn talk(&self) -> String {
16        format!("Woof, my name is {}!", self.name)
17    }
18 }
19
20 fn main() {
21    let fido = Dog { name: String::from("Fido"), age: 5 };
22    fido.greet();
23 }
```

## ▼ Speaker Notes

- To implement Trait for Type, you use an `impl Trait for Type { .. }` block.
- Unlike Go interfaces, just having matching methods is not enough: a `cat` type with a `talk()` method would not automatically satisfy `Pet` unless it is in an `impl Pet` block.
- Traits may provide default implementations of some methods. Default implementations can rely on all the methods of the trait. In this case, `greet` is provided, and relies on `talk`.
- Multiple `impl` blocks are allowed for a given type. This includes both inherent `impl` blocks and trait `impl` blocks. Likewise multiple traits can be implemented for a given type (and often types implement many traits!). `impl` blocks can even be spread across multiple modules/files.

# Supertraits

A trait can require that types implementing it also implement other traits, called *supertraits*. Here, any type implementing `Pet` must implement `Animal`.

```
1 trait Animal {
2     fn leg_count(&self) -> u32;
3 }
4
5 trait Pet: Animal {
6     fn name(&self) -> String;
7 }
8
9 struct Dog(String);
10
11 impl Animal for Dog {
12     fn leg_count(&self) -> u32 {
13         4
14     }
15 }
16
17 impl Pet for Dog {
18     fn name(&self) -> String {
19         self.0.clone()
20     }
21 }
22
23 fn main() {
24     let puppy = Dog(String::from("Rex"));
25     println!("{}", puppy.name(), puppy.leg_count());
26 }
```

## ▼ Speaker Notes

This is sometimes called “trait inheritance” but students should not expect this to behave like OO inheritance. It just specifies an additional requirement on implementations of a trait.

# Associated Types

Associated types are placeholder types which are supplied by the trait implementation.

```
1  #[derive(Debug)]
2  struct Meters(i32);
3  #[derive(Debug)]
4  struct MetersSquared(i32);
5
6  trait Multiply {
7      type Output;
8      fn multiply(&self, other: &Self) -> Self::Output;
9  }
10
11 impl Multiply for Meters {
12     type Output = MetersSquared;
13     fn multiply(&self, other: &Self) -> Self::Output {
14         MetersSquared(self.0 * other.0)
15     }
16 }
17
18 fn main() {
19     println!("{:?}", Meters(10).multiply(&Meters(20)));
20 }
```

## ▼ Speaker Notes

- Associated types are sometimes also called “output types”. The key observation is that the implementer, not the caller, chooses this type.
- Many standard library traits have associated types, including arithmetic operators and `Iterator`.

# Deriving

Supported traits can be automatically implemented for your custom types, as follows:

```

1  #[derive(Debug, Clone, Default)]
2  struct Player {
3      name: String,
4      strength: u8,
5      hit_points: u8,
6  }
7
8  fn main() {
9      let p1 = Player::default(); // Default trait adds `default` constructor.
10     let mut p2 = p1.clone(); // Clone trait adds `clone` method.
11     p2.name = String::from("EldurScrollz");
12     // Debug trait adds support for printing with `{:?}`.
13     println!("{p1:?} vs. {p2:?}");
14 }
```

## ▼ Speaker Notes

This slide should take about 3 minutes.

- Derivation is implemented with macros, and many crates provide useful derive macros to add useful functionality. For example, `serde` can derive serialization support for a struct using `#[derive(Serialize)]`.
- Derivation is usually provided for traits that have a common boilerplate-y implementation that is correct for most cases. For example, demonstrate how a manual `clone impl` can be repetitive compared to deriving the trait:

```

impl Clone for Player {
    fn clone(&self) -> Self {
        Player {
            name: self.name.clone(),
            strength: self.strength.clone(),
            hit_points: self.hit_points.clone(),
        }
    }
}
```

Not all of the `.clone()` s in the above are necessary in this case, but this demonstrates the generally boilerplate-y pattern that manual impls would follow, which should help make the use of `derive` clear to students.

# Exercise: Logger Trait

Let's design a simple logging utility, using a trait `Logger` with a `log` method. Code which might log its progress can then take an `&impl Logger`. In testing, this might put messages in the test logfile, while in a production build it would send messages to a log server.

However, the `StderrLogger` given below logs all messages, regardless of verbosity. Your task is to write a `VerbosityFilter` type that will ignore messages above a maximum verbosity.

This is a common pattern: a struct wrapping a trait implementation and implementing that same trait, adding behavior in the process. In the "Generics" segment this afternoon, we will see how to make the wrapper generic over the wrapped type.

```
1 trait Logger {
2     /// Log a message at the given verbosity level.
3     fn log(&self, verbosity: u8, message: &str);
4 }
5
6 struct StderrLogger;
7
8 impl Logger for StderrLogger {
9     fn log(&self, verbosity: u8, message: &str) {
10         eprintln!("verbosity={verbosity}: {message}");
11     }
12 }
13
14 /// Only log messages up to the given verbosity level.
15 struct VerbosityFilter {
16     max_verbosity: u8,
17     inner: StderrLogger,
18 }
19
20 // TODO: Implement the `Logger` trait for `VerbosityFilter`.
21
22 fn main() {
23     let logger = VerbosityFilter { max_verbosity: 3, inner: StderrLogger };
24     logger.log(5, "FYI");
25     logger.log(2, "Uhoh");
26 }
```



# Solution

```
1 trait Logger {
2     /// Log a message at the given verbosity level.
3     fn log(&self, verbosity: u8, message: &str);
4 }
5
6 struct StderrLogger;
7
8 impl Logger for StderrLogger {
9     fn log(&self, verbosity: u8, message: &str) {
10         eprintln!("verbosity={verbosity}: {message}");
11     }
12 }
13
14 /// Only log messages up to the given verbosity level.
15 struct VerbosityFilter {
16     max_verbosity: u8,
17     inner: StderrLogger,
18 }
19
20 impl Logger for VerbosityFilter {
21     fn log(&self, verbosity: u8, message: &str) {
22         if verbosity <= self.max_verbosity {
23             self.inner.log(verbosity, message);
24         }
25     }
26 }
27
28 fn main() {
29     let logger = VerbosityFilter { max_verbosity: 3, inner: StderrLogger };
30     logger.log(5, "FYI");
31     logger.log(2, "Uhoh");
32 }
```

# Generics

This segment should take about 45 minutes. It contains:

Slide	Duration
Generic Functions	5 minutes
Trait Bounds	10 minutes
Generic Data Types	10 minutes
impl Trait	5 minutes
dyn Trait	5 minutes
Exercise: Generic min	10 minutes

# Generic Functions

Rust supports generics, which lets you abstract algorithms or data structures (such as sorting or a binary tree) over the types used or stored.

```
1 fn pick<T>(cond: bool, left: T, right: T) -> T {
2     if cond {
3         left
4     } else {
5         right
6     }
7 }
8
9 fn main() {
10    println!("picked a number: {:?}", pick(true, 222, 333));
11    println!("picked a string: {:?}", pick(false, 'L', 'R'));
12 }
```

## ▼ Speaker Notes

This slide should take about 5 minutes.

- It can be helpful to show the monomorphized versions of `pick`, either before talking about the generic `pick` in order to show how generics can reduce code duplication, or after talking about generics to show how monomorphization works.

```
fn pick_i32(cond: bool, left: i32, right: i32) -> i32 {
    if cond {
        left
    } else {
        right
    }
}
```

```
fn pick_char(cond: bool, left: char, right: char) -> char {
    if cond {
        left
    } else {
        right
    }
}
```

- Rust infers a type for `T` based on the types of the arguments and return value.

- In this example we only use the primitive types `i32` and `char` for  $\tau$ , but we can use any type here, including user-defined types:

```
struct Foo {  
    val: u8,  
}
```

```
pick(123, Foo { val: 7 }, Foo { val: 456 });
```

- This is similar to C++ templates, but Rust partially compiles the generic function immediately, so that function must be valid for all types matching the constraints. For example, try modifying `pick` to return `even + odd` if `n == 0`. Even if only the `pick` instantiation with integers is used, Rust still considers it invalid. C++ would let you do this.
- Generic code is turned into non-generic code based on the call sites. This is a zero-cost abstraction: you get exactly the same result as if you had hand-coded the data structures without the abstraction.

# Trait Bounds

When working with generics, you often want to require the types to implement some trait, so that you can call this trait's methods.

You can do this with `T: Trait`:

```

1  fn duplicate<T: Clone>(a: T) -> (T, T) {
2      (a.clone(), a.clone())
3  }
4
5  struct NotCloneable;
6
7  fn main() {
8      let foo = String::from("foo");
9      let pair = duplicate(foo);
10     println!("{pair:?}");
11 }
```

## ▼ Speaker Notes

This slide should take about 8 minutes.

- Try making a `NotCloneable` and passing it to `duplicate`.
- When multiple traits are necessary, use `+` to join them.
- Show a `where` clause, students will encounter it when reading code.

```

fn duplicate<T>(a: T) -> (T, T)
where
    T: Clone,
{
    (a.clone(), a.clone())
}
```

- It declutters the function signature if you have many parameters.
- It has additional features making it more powerful.
  - If someone asks, the extra feature is that the type on the left of ":" can be arbitrary, like `option<T>`.
- Note that Rust does not (yet) support specialization. For example, given the original `duplicate`, it is invalid to add a specialized `duplicate(a: u32)`.

# Generic Data Types

You can use generics to abstract over the concrete field type. Returning to the exercise for the previous segment:

```

1  pub trait Logger {
2      /// Log a message at the given verbosity level.
3      fn log(&self, verbosity: u8, message: &str);
4  }
5
6  struct StderrLogger;
7
8  impl Logger for StderrLogger {
9      fn log(&self, verbosity: u8, message: &str) {
10         eprintln!("verbosity={verbosity}: {message}");
11     }
12 }
13
14 /// Only log messages up to the given verbosity level.
15 struct VerbosityFilter<L> {
16     max_verbosity: u8,
17     inner: L,
18 }
19
20 impl<L: Logger> Logger for VerbosityFilter<L> {
21     fn log(&self, verbosity: u8, message: &str) {
22         if verbosity <= self.max_verbosity {
23             self.inner.log(verbosity, message);
24         }
25     }
26 }
27
28 fn main() {
29     let logger = VerbosityFilter { max_verbosity: 3, inner: StderrLogger };
30     logger.log(5, "FYI");
31     logger.log(2, "Uhoh");
32 }

```

## ▼ Speaker Notes

This slide should take about 10 minutes.

- Q: Why `L` is specified twice in `impl<L: Logger> .. VerbosityFilter<L>`? Isn't that redundant?
  - This is because it is a generic implementation section for generic type. They are independently generic.
  - It means these methods are defined for any `L`.
  - It is possible to write `impl VerbosityFilter<StderrLogger> { .. }`.

- `VerbosityFilter` is still generic and you can use `VerbosityFilter<f64>`, but methods in this block will only be available for `VerbosityFilter<StderrLogger>`.
- Note that we don't put a trait bound on the `VerbosityFilter` type itself. You can put bounds there as well, but generally in Rust we only put the trait bounds on the impl blocks.

# Generic Traits

Traits can also be generic, just like types and functions. A trait's parameters get concrete types when it is used. For example the `From<T>` trait is used to define type conversions:

```
pub trait From<T>: Sized {
    fn from(value: T) -> Self;
}

1  #[derive(Debug)]
2  struct Foo(String);
3
4  impl From<u32> for Foo {
5      fn from(from: u32) -> Foo {
6          Foo(format!("Converted from integer: {from}"))
7      }
8  }
9
10 impl From<bool> for Foo {
11     fn from(from: bool) -> Foo {
12         Foo(format!("Converted from bool: {from}"))
13     }
14 }
15
16 fn main() {
17     let from_int = Foo::from(123);
18     let from_bool = Foo::from(true);
19     dbg!(from_int);
20     dbg!(from_bool);
21 }
```

## ▼ Speaker Notes

- The `From` trait will be covered later in the course, but its [definition in the std docs](#) is simple, and copied here for reference.
- Implementations of the trait do not need to cover all possible type parameters. Here, `Foo::from("hello")` would not compile because there is no `From<&str>` implementation for `Foo`.
- Generic traits take types as “input”, while associated types are a kind of “output” type. A trait can have multiple implementations for different input types.



- In fact, Rust requires that at most one implementation of a trait match for any type T. Unlike some other languages, Rust has no heuristic for choosing the “most specific” match. There is work on adding this support, called [specialization](#).

# impl Trait

Similar to trait bounds, an `impl Trait` syntax can be used in function arguments and return values:

```

1  // Syntactic sugar for:
2  // fn add_42_millions<T: Into<i32>>(x: T) -> i32 {
3  fn add_42_millions(x: impl Into<i32>) -> i32 {
4      x.into() + 42_000_000
5  }
6
7  fn pair_of(x: u32) -> impl std::fmt::Debug {
8      (x + 1, x - 1)
9  }
10
11 fn main() {
12     let many = add_42_millions(42_i8);
13     dbg!(many);
14     let many_more = add_42_millions(10_000_000);
15     dbg!(many_more);
16     let debuggable = pair_of(27);
17     dbg!(debuggable);
18 }
```

## ▼ Speaker Notes

This slide should take about 5 minutes.

`impl Trait` allows you to work with types which you cannot name. The meaning of `impl Trait` is a bit different in the different positions.

- For a parameter, `impl Trait` is like an anonymous generic parameter with a trait bound.
- For a return type, it means that the return type is some concrete type that implements the trait, without naming the type. This can be useful when you don't want to expose the concrete type in a public API.

Inference is hard in return position. A function returning `impl Foo` picks the concrete type it returns, without writing it out in the source. A function returning a generic type like `collect<B>() -> B` can return any type satisfying `B`, and the caller may need to choose one, such as with `let x: Vec<_> = foo.collect()` or with the turbofish, `foo.collect::.`

What is the type of `debuggable`? Try `let debuggable: () = ..` to see what the error message shows.

# dyn Trait

In addition to using traits for static dispatch via generics, Rust also supports using them for type-erased, dynamic dispatch via trait objects:

```
1 struct Dog {
2     name: String,
3     age: i8,
4 }
5 struct Cat {
6     lives: i8,
7 }
8
9 trait Pet {
10     fn talk(&self) -> String;
11 }
12
13 impl Pet for Dog {
14     fn talk(&self) -> String {
15         format!("Woof, my name is {}!", self.name)
16     }
17 }
18
19 impl Pet for Cat {
20     fn talk(&self) -> String {
21         String::from("Miau!")
22     }
23 }
24
25 // Uses generics and static dispatch.
26 fn generic(pet: &impl Pet) {
27     println!("Hello, who are you? {}", pet.talk());
28 }
29
30 // Uses type-erasure and dynamic dispatch.
31 fn dynamic(pet: &dyn Pet) {
32     println!("Hello, who are you? {}", pet.talk());
33 }
34
35 fn main() {
36     let cat = Cat { lives: 9 };
37     let dog = Dog { name: String::from("Fido"), age: 5 };
38
39     generic(&cat);
40     generic(&dog);
41
42     dynamic(&cat);
43     dynamic(&dog);
44 }
```

## ▼ *Speaker Notes*

This slide should take about 5 minutes.

- Generics, including `impl Trait`, use monomorphization to create a specialized instance of the function for each different type that the generic is instantiated with. This means that calling a trait method from within a generic function still uses static dispatch, as the compiler has full type information and can resolve which type's trait implementation to use.
- When using `dyn Trait`, it instead uses dynamic dispatch through a [virtual method table](#) (vtable). This means that there's a single version of `fn dynamic` that is used regardless of what type of `Pet` is passed in.
- When using `dyn Trait`, the trait object needs to be behind some kind of indirection. In this case it's a reference, though smart pointer types like `Box` can also be used (this will be demonstrated on day 3).
- At runtime, a `&dyn Pet` is represented as a "fat pointer", i.e. a pair of two pointers: One pointer points to the concrete object that implements `Pet`, and the other points to the vtable for the trait implementation for that type. When calling the `talk` method on `&dyn Pet` the compiler looks up the function pointer for `talk` in the vtable and then invokes the function, passing the pointer to the `Dog` or `Cat` into that function. The compiler doesn't need to know the concrete type of the `Pet` in order to do this.
- A `dyn Trait` is considered to be "type-erased", because we no longer have compile-time knowledge of what the concrete type is.

# Exercise: Generic `min`

In this short exercise, you will implement a generic `min` function that determines the minimum of two values, using the `Ord` trait.

```
1 use std::cmp::Ordering;
2
3 // TODO: implement the `min` function used in the tests.
4
5 #[test]
6 fn integers() {
7     assert_eq!(min(0, 10), 0);
8     assert_eq!(min(500, 123), 123);
9 }
10
11 #[test]
12 fn chars() {
13     assert_eq!(min('a', 'z'), 'a');
14     assert_eq!(min('7', '1'), '1');
15 }
16
17 #[test]
18 fn strings() {
19     assert_eq!(min("hello", "goodbye"), "goodbye");
20     assert_eq!(min("bat", "armadillo"), "armadillo");
21 }
```

## ▼ Speaker Notes

This slide and its sub-slides should take about 10 minutes.

- Show students the `Ord` trait and `Ordering` enum.

# Solution

```
1 use std::cmp::Ordering;
2
3 fn min<T: Ord>(l: T, r: T) -> T {
4     match l.cmp(&r) {
5         Ordering::Less | Ordering::Equal => l,
6         Ordering::Greater => r,
7     }
8 }
9
10 #[test]
11 fn integers() {
12     assert_eq!(min(0, 10), 0);
13     assert_eq!(min(500, 123), 123);
14 }
15
16 #[test]
17 fn chars() {
18     assert_eq!(min('a', 'z'), 'a');
19     assert_eq!(min('7', '1'), '1');
20 }
21
22 #[test]
23 fn strings() {
24     assert_eq!(min("hello", "goodbye"), "goodbye");
25     assert_eq!(min("bat", "armadillo"), "armadillo");
26 }
```

# Welcome Back

Including 10 minute breaks, this session should take about 2 hours and 40 minutes. It contains:

Segment	Duration
Standard Library Types	1 hour
Standard Library Traits	1 hour
Closures	20 minutes



# Standard Library Types

This segment should take about 1 hour. It contains:

Slide	Duration
Standard Library	3 minutes
Documentation	5 minutes
Option	10 minutes
Result	5 minutes
String	5 minutes
Vec	5 minutes
HashMap	5 minutes
Exercise: Counter	20 minutes

## ▼ *Speaker Notes*

For each of the slides in this section, spend some time reviewing the documentation pages, highlighting some of the more common methods.

# Standard Library

Rust comes with a standard library which helps establish a set of common types used by Rust libraries and programs. This way, two libraries can work together smoothly because they both use the same `String` type.

In fact, Rust contains several layers of the Standard Library: `core`, `alloc` and `std`.

- `core` includes the most basic types and functions that don't depend on `libc`, allocator or even the presence of an operating system.
- `alloc` includes types which require a global heap allocator, such as `Vec`, `Box` and `Arc`.
- Embedded Rust applications often only use `core`, and sometimes `alloc`.

# Documentation

Rust comes with extensive documentation. For example:

- All of the details about [loops](#).
- Primitive types like [u8](#).
- Standard library types like [Option](#) or [BinaryHeap](#).

Use `rustup doc --std` or <https://std.rs> to view the documentation.

In fact, you can document your own code:

```
1 /// Determine whether the first argument is divisible by the second argument.
2 ///
3 /// If the second argument is zero, the result is false.
4 fn is_divisible_by(lhs: u32, rhs: u32) -> bool {
5     if rhs == 0 {
6         return false;
7     }
8     lhs % rhs == 0
9 }
```

The contents are treated as Markdown. All published Rust library crates are automatically documented at [docs.rs](https://docs.rs) using the [rustdoc](#) tool. It is idiomatic to document all public items in an API using this pattern.

To document an item from inside the item (such as inside a module), use `//!` or `/*! .. */`, called “inner doc comments”:

```
1 //! This module contains functionality relating to divisibility of integers.
```

## ▼ Speaker Notes

This slide should take about 5 minutes.

- Show students the generated docs for the `rand` crate at <https://docs.rs/rand>.

# Option

We have already seen some use of `Option<T>`. It stores either a value of type `T` or nothing. For example, `String::find` returns an `Option<usize>`.

```
1 fn main() {
2     let name = "Löwe 老虎 Léopard Gepardi";
3     let mut position: Option<usize> = name.find('é');
4     dbg!(position);
5     assert_eq!(position.unwrap(), 14);
6     position = name.find('Z');
7     dbg!(position);
8     assert_eq!(position.expect("Character not found"), 0);
9 }
```

## ▼ Speaker Notes

This slide should take about 10 minutes.

- `Option` is widely used, not just in the standard library.
- `unwrap` will return the value in an `Option`, or panic. `expect` is similar but takes an error message.
  - You can panic on `None`, but you can't "accidentally" forget to check for `None`.
  - It's common to `unwrap` / `expect` all over the place when hacking something together, but production code typically handles `None` in a nicer fashion.
- The "niche optimization" means that `Option<T>` often has the same size in memory as `T`, if there is some representation that is not a valid value of `T`. For example, a reference cannot be `NULL`, so `Option<&T>` automatically uses `NULL` to represent the `None` variant, and thus can be stored in the same memory as `&T`.

# Result

`Result` is similar to `Option`, but indicates the success or failure of an operation, each with a different enum variant. It is generic: `Result<T, E>` where `T` is used in the `Ok` variant and `E` appears in the `Err` variant.

```
1 use std::fs::File;
2 use std::io::Read;
3
4 fn main() {
5     let file: Result<File, std::io::Error> = File::open("diary.txt");
6     match file {
7         Ok(mut file) => {
8             let mut contents = String::new();
9             if let Ok(bytes) = file.read_to_string(&mut contents) {
10                println!("Dear diary: {contents} ({bytes} bytes)");
11            } else {
12                println!("Could not read file content");
13            }
14        }
15        Err(err) => {
16            println!("The diary could not be opened: {err}");
17        }
18    }
19 }
```

## ▼ Speaker Notes

This slide should take about 5 minutes.

- As with `Option`, the successful value sits inside of `Result`, forcing the developer to explicitly extract it. This encourages error checking. In the case where an error should never happen, `unwrap()` or `expect()` can be called, and this is a signal of the developer intent too.
- `Result` documentation is a recommended read. Not during the course, but it is worth mentioning. It contains a lot of convenience methods and functions that help functional-style programming.
- `Result` is the standard type to implement error handling as we will see on Day 4.

# String

`String` is a growable UTF-8 encoded string:

```

1 fn main() {
2     let mut s1 = String::new();
3     s1.push_str("Hello");
4     println!("s1: len = {}, capacity = {}", s1.len(), s1.capacity());
5
6     let mut s2 = String::with_capacity(s1.len() + 1);
7     s2.push_str(&s1);
8     s2.push('!');
9     println!("s2: len = {}, capacity = {}", s2.len(), s2.capacity());
10
11     let s3 = String::from("C H ");
12     println!("s3: len = {}, number of chars = {}", s3.len(), s3.chars().count());
13 }
```

`String` implements `Deref<Target = str>`, which means that you can call all `str` methods on a `String`.

## ▼ Speaker Notes

This slide should take about 5 minutes.

- `String::new` returns a new empty string, use `String::with_capacity` when you know how much data you want to push to the string.
- `String::len` returns the size of the `String` in bytes (which can be different from its length in characters).
- `String::chars` returns an iterator over the actual characters. Note that a `char` can be different from what a human will consider a “character” due to [grapheme clusters](#).
- When people refer to strings they could either be talking about `&str` or `String`.
- When a type implements `Deref<Target = T>`, the compiler will let you transparently call methods from `T`.
  - We haven’t discussed the `Deref` trait yet, so at this point this mostly explains the structure of the sidebar in the documentation.
  - `String` implements `Deref<Target = str>` which transparently gives it access to `str`’s methods.
  - Write and compare `let s3 = s1.deref();` and `let s3 = &*s1;`
- `String` is implemented as a wrapper around a vector of bytes, many of the operations you see supported on vectors are also supported on `String`, but with some extra guarantees.
- Compare the different ways to index a `String`:

- To a character by using `s3.chars().nth(i).unwrap()` where `i` is in-bound, out-of-bounds.
- To a substring by using `s3[0..4]`, where that slice is on character boundaries or not.
- Many types can be converted to a string with the `to_string` method. This trait is automatically implemented for all types that implement `Display`, so anything that can be formatted can also be converted to a string.

# Vec

`Vec` is the standard resizable heap-allocated buffer:

```

1  fn main() {
2      let mut v1 = Vec::new();
3      v1.push(42);
4      println!("v1: len = {}, capacity = {}", v1.len(), v1.capacity());
5
6      let mut v2 = Vec::with_capacity(v1.len() + 1);
7      v2.extend(v1.iter());
8      v2.push(9999);
9      println!("v2: len = {}, capacity = {}", v2.len(), v2.capacity());
10
11     // Canonical macro to initialize a vector with elements.
12     let mut v3 = vec![0, 0, 1, 2, 3, 4];
13
14     // Retain only the even elements.
15     v3.retain(|x| x % 2 == 0);
16     println!("{v3:?}");
17
18     // Remove consecutive duplicates.
19     v3.dedup();
20     println!("{v3:?}");
21 }

```

`Vec` implements `Deref<Target = [T]>`, which means that you can call slice methods on a `Vec`.

## ▼ Speaker Notes

This slide should take about 5 minutes.

- `Vec` is a type of collection, along with `String` and `HashMap`. The data it contains is stored on the heap. This means the amount of data doesn't need to be known at compile time. It can grow or shrink at runtime.
- Notice how `Vec<T>` is a generic type too, but you don't have to specify `T` explicitly. As always with Rust type inference, the `T` was established during the first `push` call.
- `vec![...]` is a canonical macro to use instead of `Vec::new()` and it supports adding initial elements to the vector.
- To index the vector you use `[ ]`, but they will panic if out of bounds. Alternatively, using `get` will return an `Option`. The `pop` function will remove the last element.
- Slices are covered on day 3. For now, students only need to know that a value of type `Vec` gives access to all of the documented slice methods, too.



# HashMap

Standard hash map with protection against HashDoS attacks:

```
1 use std::collections::HashMap;
2
3 fn main() {
4     let mut page_counts = HashMap::new();
5     page_counts.insert("Adventures of Huckleberry Finn", 207);
6     page_counts.insert("Grimms' Fairy Tales", 751);
7     page_counts.insert("Pride and Prejudice", 303);
8
9     if !page_counts.contains_key("Les Misérables") {
10        println!(
11            "We know about {} books, but not Les Misérables.",
12            page_counts.len()
13        );
14    }
15
16    for book in ["Pride and Prejudice", "Alice's Adventure in Wonderland"] {
17        match page_counts.get(book) {
18            Some(count) => println!("{}: {} pages"),
19            None => println!("{} is unknown."),
20        }
21    }
22
23    // Use the .entry() method to insert a value if nothing is found.
24    for book in ["Pride and Prejudice", "Alice's Adventure in Wonderland"] {
25        let page_count: &mut i32 = page_counts.entry(book).or_insert(0);
26        *page_count += 1;
27    }
28
29    dbg!(page_counts);
30 }
```

## ▼ Speaker Notes

This slide should take about 5 minutes.

- `HashMap` is not defined in the prelude and needs to be brought into scope.
- Try the following lines of code. The first line will see if a book is in the hashmap and if not return an alternative value. The second line will insert the alternative value in the hashmap if the book is not found.

```
let pc1 = page_counts
    .get("Harry Potter and the Sorcerer's Stone")
    .unwrap_or(&336);
let pc2 = page_counts
    .entry("The Hunger Games")
    .or_insert(374);
```

- Unlike `vec!`, there is unfortunately no standard `hashmap!` macro.
  - Although, since Rust 1.56, `HashMap` implements `From<[(K, V); N]>`, which allows us to easily initialize a hash map from a literal array:

```
let page_counts = HashMap::from([
    ("Harry Potter and the Sorcerer's Stone".to_string(), 336),
    ("The Hunger Games".to_string(), 374),
]);
```

- Alternatively `HashMap` can be built from any `Iterator` which yields key-value tuples.
- This type has several “method-specific” return types, such as `std::collections::hash_map::Keys`. These types often appear in searches of the Rust docs. Show students the docs for this type, and the helpful link back to the `keys` method.

# Exercise: Counter

In this exercise you will take a very simple data structure and make it generic. It uses a `std::collections::HashMap` to keep track of which values have been seen and how many times each one has appeared.

The initial version of `Counter` is hard coded to only work for `u32` values. Make the struct and its methods generic over the type of value being tracked, that way `Counter` can track any type of value.

If you finish early, try using the `entry` method to halve the number of hash lookups required to implement the `count` method.

```
1 use std::collections::HashMap;
2
3 /// Counter counts the number of times each value of type T has been seen.
4 struct Counter {
5     values: HashMap<u32, u64>,
6 }
7
8 impl Counter {
9     /// Create a new Counter.
10    fn new() -> Self {
11        Counter {
12            values: HashMap::new(),
13        }
14    }
15
16    /// Count an occurrence of the given value.
17    fn count(&mut self, value: u32) {
18        if self.values.contains_key(&value) {
19            *self.values.get_mut(&value).unwrap() += 1;
20        } else {
21            self.values.insert(value, 1);
22        }
23    }
24
25    /// Return the number of times the given value has been seen.
26    fn times_seen(&self, value: u32) -> u64 {
27        self.values.get(&value).copied().unwrap_or_default()
28    }
29 }
30
31 fn main() {
32     let mut ctr = Counter::new();
33     ctr.count(13);
34     ctr.count(14);
35     ctr.count(16);
36     ctr.count(14);
37     ctr.count(14);
38     ctr.count(11);
39
40     for i in 10..20 {
41         println!("saw {} values equal to {}", ctr.times_seen(i), i);
42     }
43
44     let mut strctr = Counter::new();
45     strctr.count("apple");
46     strctr.count("orange");
47     strctr.count("apple");
48     println!("got {} apples", strctr.times_seen("apple"));
49 }
```

# Solution

```
1 use std::collections::HashMap;
2 use std::hash::Hash;
3
4 /// Counter counts the number of times each value of type T has been seen.
5 struct Counter<T> {
6     values: HashMap<T, u64>,
7 }
8
9 impl<T: Eq + Hash> Counter<T> {
10     /// Create a new Counter.
11     fn new() -> Self {
12         Counter { values: HashMap::new() }
13     }
14
15     /// Count an occurrence of the given value.
16     fn count(&mut self, value: T) {
17         *self.values.entry(value).or_default() += 1;
18     }
19
20     /// Return the number of times the given value has been seen.
21     fn times_seen(&self, value: T) -> u64 {
22         self.values.get(&value).copied().unwrap_or_default()
23     }
24 }
25
26 fn main() {
27     let mut ctr = Counter::new();
28     ctr.count(13);
29     ctr.count(14);
30     ctr.count(16);
31     ctr.count(14);
32     ctr.count(14);
33     ctr.count(11);
34
35     for i in 10..20 {
36         println!("saw {} values equal to {}", ctr.times_seen(i), i);
37     }
38
39     let mut strctr = Counter::new();
40     strctr.count("apple");
41     strctr.count("orange");
42     strctr.count("apple");
43     println!("got {} apples", strctr.times_seen("apple"));
44 }
```

# Standard Library Traits

This segment should take about 1 hour. It contains:

Slide	Duration
Comparisons	5 minutes
Operators	5 minutes
From and Into	5 minutes
Casting	5 minutes
Read and Write	5 minutes
Default, struct update syntax	5 minutes
Exercise: ROT13	30 minutes

## ▼ *Speaker Notes*

As with the standard-library types, spend time reviewing the documentation for each trait.

This section is long. Take a break midway through.

# Comparisons

These traits support comparisons between values. All traits can be derived for types containing fields that implement these traits.

## PartialEq and Eq

`PartialEq` is a partial equivalence relation, with required method `eq` and provided method `ne`. The `==` and `!=` operators will call these methods.

```
1 struct Key {
2     id: u32,
3     metadata: Option<String>,
4 }
5 impl PartialEq for Key {
6     fn eq(&self, other: &Self) -> bool {
7         self.id == other.id
8     }
9 }
```

`Eq` is a full equivalence relation (reflexive, symmetric, and transitive) and implies `PartialEq`. Functions that require full equivalence will use `Eq` as a trait bound.

## PartialOrd and Ord

`PartialOrd` defines a partial ordering, with a `partial_cmp` method. It is used to implement the `<`, `<=`, `>=`, and `>` operators.

```
1 use std::cmp::Ordering;
2 #[derive(Eq, PartialEq)]
3 struct Citation {
4     author: String,
5     year: u32,
6 }
7 impl PartialOrd for Citation {
8     fn partial_cmp(&self, other: &Self) -> Option<Ordering> {
9         match self.author.partial_cmp(&other.author) {
10             Some(Ordering::Equal) => self.year.partial_cmp(&other.year),
11             author_ord => author_ord,
12         }
13     }
14 }
```

`Ord` is a total ordering, with `cmp` returning `Ordering`.

### ▼ *Speaker Notes*

This slide should take about 5 minutes.

- `PartialEq` can be implemented between different types, but `Eq` cannot, because it is reflexive:

```
1 struct Key {
2     id: u32,
3     metadata: Option<String>,
4 }
5 impl PartialEq<u32> for Key {
6     fn eq(&self, other: &u32) -> bool {
7         self.id == *other
8     }
9 }
```

- In practice, it's common to derive these traits, but uncommon to implement them.
- When comparing references in Rust, it will compare the value of the things pointed to, it will NOT compare the references themselves. That means that references to two different things can compare as equal if the values pointed to are the same:

```
1 fn main() {
2     let a = "Hello";
3     let b = String::from("Hello");
4     assert_eq!(a, b);
5 }
```



# Operators

Operator overloading is implemented via traits in `std::ops`:

```

1  #[derive(Debug, Copy, Clone)]
2  struct Point {
3      x: i32,
4      y: i32,
5  }
6
7  impl std::ops::Add for Point {
8      type Output = Self;
9
10     fn add(self, other: Self) -> Self {
11         Self { x: self.x + other.x, y: self.y + other.y }
12     }
13 }
14
15 fn main() {
16     let p1 = Point { x: 10, y: 20 };
17     let p2 = Point { x: 100, y: 200 };
18     println!("{p1:?} + {p2:?} = {:?}", p1 + p2);
19 }

```

## ▼ Speaker Notes

This slide should take about 5 minutes.

Discussion points:

- You could implement `Add` for `&Point`. In which situations is that useful?
  - Answer: `Add::add` consumes `self`. If type `T` for which you are overloading the operator is not `Copy`, you should consider overloading the operator for `&T` as well. This avoids unnecessary cloning on the call site.
- Why is `Output` an associated type? Could it be made a type parameter of the method?
  - Short answer: Function type parameters are controlled by the caller, but associated types (like `Output`) are controlled by the implementer of a trait.
- You could implement `Add` for two different types, e.g. `impl Add<(i32, i32)> for Point` would add a tuple to a `Point`.

The `Not` trait (`!` operator) is notable because it does not “boolify” like the same operator in C-family languages; instead, for integer types it negates each bit of the number, which arithmetically is equivalent to subtracting it from -1: `!5 == -6`.

# From and Into

Types implement `From` and `Into` to facilitate type conversions. Unlike `as`, these traits correspond to lossless, infallible conversions.

```
1 fn main() {
2     let s = String::from("hello");
3     let addr = std::net::Ipv4Addr::from([127, 0, 0, 1]);
4     let one = i16::from(true);
5     let bigger = i32::from(123_i16);
6     println!("{s}, {addr}, {one}, {bigger}");
7 }
```

`Into` is automatically implemented when `From` is implemented:

```
1 fn main() {
2     let s: String = "hello".into();
3     let addr: std::net::Ipv4Addr = [127, 0, 0, 1].into();
4     let one: i16 = true.into();
5     let bigger: i32 = 123_i16.into();
6     println!("{s}, {addr}, {one}, {bigger}");
7 }
```

## ▼ Speaker Notes

This slide should take about 5 minutes.

- That's why it is common to only implement `From`, as your type will get `Into` implementation too.
- When declaring a function argument input type like "anything that can be converted into a `String`", the rule is opposite, you should use `Into`. Your function will accept types that implement `From` and those that *only* implement `Into`.

# Casting

Rust has no *implicit* type conversions, but does support explicit casts with `as`. These generally follow C semantics where those are defined.

```
1 fn main() {
2     let value: i64 = 1000;
3     println!("as u16: {}", value as u16);
4     println!("as i16: {}", value as i16);
5     println!("as u8: {}", value as u8);
6 }
```

The results of `as` are *always* defined in Rust and consistent across platforms. This might not match your intuition for changing sign or casting to a smaller type – check the docs, and comment for clarity.

Casting with `as` is a relatively sharp tool that is easy to use incorrectly, and can be a source of subtle bugs as future maintenance work changes the types that are used or the ranges of values in types. Casts are best used only when the intent is to indicate unconditional truncation (e.g. selecting the bottom 32 bits of a `u64` with `as u32`, regardless of what was in the high bits).

For infallible casts (e.g. `u32` to `u64`), prefer using `From` or `Into` over `as` to confirm that the cast is in fact infallible. For fallible casts, `TryFrom` and `TryInto` are available when you want to handle casts that fit differently from those that don't.

## ▼ Speaker Notes

This slide should take about 5 minutes.

Consider taking a break after this slide.

`as` is similar to a C++ static cast. Use of `as` in cases where data might be lost is generally discouraged, or at least deserves an explanatory comment.

This is common in casting integers to `usize` for use as an index.

# Read and Write

Using `Read` and `BufRead`, you can abstract over `u8` sources:

```
1 use std::io::{BufRead, BufReader, Read, Result};
2
3 fn count_lines<R: Read>(reader: R) -> usize {
4     let buf_reader = BufReader::new(reader);
5     buf_reader.lines().count()
6 }
7
8 fn main() -> Result<()> {
9     let slice: &[u8] = b"foo\nbar\nbaz\n";
10    println!("lines in slice: {}", count_lines(slice));
11
12    let file = std::fs::File::open(std::env::current_exe())?;
13    println!("lines in file: {}", count_lines(file));
14    Ok(())
15 }
```

Similarly, `Write` lets you abstract over `u8` sinks:

```
1 use std::io::{Result, Write};
2
3 fn log<W: Write>(writer: &mut W, msg: &str) -> Result<()> {
4     writer.write_all(msg.as_bytes())?;
5     writer.write_all("\n".as_bytes())
6 }
7
8 fn main() -> Result<()> {
9     let mut buffer = Vec::new();
10    log(&mut buffer, "Hello");
11    log(&mut buffer, "World");
12    println!("Logged: {buffer:?}");
13    Ok(())
14 }
```

# The Default Trait

`Default` trait produces a default value for a type.

```
1  #[derive(Debug, Default)]
2  struct Derived {
3      x: u32,
4      y: String,
5      z: Implemented,
6  }
7
8  #[derive(Debug)]
9  struct Implemented(String);
10
11 impl Default for Implemented {
12     fn default() -> Self {
13         Self("John Smith".into())
14     }
15 }
16
17 fn main() {
18     let default_struct = Derived::default();
19     dbg!(default_struct);
20
21     let almost_default_struct =
22         Derived { y: "Y is set!".into(), ..Derived::default() };
23     dbg!(almost_default_struct);
24
25     let nothing: Option<Derived> = None;
26     dbg!(nothing.unwrap_or_default());
27 }
```

## ▼ Speaker Notes

This slide should take about 5 minutes.

- It can be implemented directly or it can be derived via `#[derive(Default)]`.
- A derived implementation will produce a value where all fields are set to their default values.
  - This means all types in the struct must implement `Default` too.
- Standard Rust types often implement `Default` with reasonable values (e.g. `0`, `""`, etc).
- The partial struct initialization works nicely with `default`.
- The Rust standard library is aware that types can implement `Default` and provides convenience methods that use it.
- The `..` syntax is called [struct update syntax](#).

# Exercise: ROT13

In this example, you will implement the classic “ROT13” cipher. Copy this code to the playground, and implement the missing bits. Only rotate ASCII alphabetic characters, to ensure the result is still valid UTF-8.

```

1  use std::io::Read;
2
3  struct RotDecoder<R: Read> {
4      input: R,
5      rot: u8,
6  }
7
8  // Implement the `Read` trait for `RotDecoder`.
9
10 #[cfg(test)]
11 mod test {
12     use super::*;
13
14     #[test]
15     fn joke() {
16         let mut rot =
17             RotDecoder { input: "Gb trg gb gur bgure fvqr!".as_bytes(), rot: 13 };
18         let mut result = String::new();
19         rot.read_to_string(&mut result).unwrap();
20         assert_eq!(&result, "To get to the other side!");
21     }
22
23     #[test]
24     fn binary() {
25         let input: Vec<u8> = (0..=255u8).collect();
26         let mut rot = RotDecoder:::<&[u8]> { input: input.as_ref(), rot: 13 };
27         let mut buf = [0u8; 256];
28         assert_eq!(rot.read(&mut buf).unwrap(), 256);
29         for i in 0..=255 {
30             if input[i] != buf[i] {
31                 assert!(input[i].is_ascii_alphabetic());
32                 assert!(buf[i].is_ascii_alphabetic());
33             }
34         }
35     }
36 }

```

What happens if you chain two `RotDecoder` instances together, each rotating by 13 characters?

# Solution

```

1 use std::io::Read;
2
3 struct RotDecoder<R: Read> {
4     input: R,
5     rot: u8,
6 }
7
8 impl<R: Read> Read for RotDecoder<R> {
9     fn read(&mut self, buf: &mut [u8]) -> std::io::Result<usize> {
10         let size = self.input.read(buf)?;
11         for b in &mut buf[..size] {
12             if b.is_ascii_alphabetic() {
13                 let base = if b.is_ascii_uppercase() { 'A' } else { 'a' } as u8;
14                 *b = (*b - base + self.rot) % 26 + base;
15             }
16         }
17         Ok(size)
18     }
19 }
20
21 #[cfg(test)]
22 mod test {
23     use super::*;
24
25     #[test]
26     fn joke() {
27         let mut rot =
28             RotDecoder { input: "Gb trg gb gur bgure fvqr!".as_bytes(), rot: 13 };
29         let mut result = String::new();
30         rot.read_to_string(&mut result).unwrap();
31         assert_eq!(&result, "To get to the other side!");
32     }
33
34     #[test]
35     fn binary() {
36         let input: Vec<u8> = (0..=255u8).collect();
37         let mut rot = RotDecoder:::<&[u8]> { input: input.as_ref(), rot: 13 };
38         let mut buf = [0u8; 256];
39         assert_eq!(rot.read(&mut buf).unwrap(), 256);
40         for i in 0..=255 {
41             if input[i] != buf[i] {
42                 assert!(input[i].is_ascii_alphabetic());
43                 assert!(buf[i].is_ascii_alphabetic());
44             }
45         }
46     }
47 }

```

# Closures

This segment should take about 20 minutes. It contains:

Slide	Duration
Closure Syntax	3 minutes
Capturing	5 minutes
Closure Traits	10 minutes



# Closure Syntax

Closures are created with vertical bars: `|..| ..`

```
1 fn main() {
2     // Argument and return type can be inferred for lightweight syntax:
3     let double_it = |n| n * 2;
4     dbg!(double_it(50));
5
6     // Or we can specify types and bracket the body to be fully explicit:
7     let add_1f32 = |x: f32| -> f32 { x + 1.0 };
8     dbg!(add_1f32(50.));
9 }
```

## ▼ Speaker Notes

This slide should take about 3 minutes.

- The arguments go between the `|..|`. The body can be surrounded by `{ .. }`, but if it is a single expression these can be omitted.
- Argument types are optional, and are inferred if not given. The return type is also optional, but can only be written if using `{ .. }` around the body.
- The examples can both be written as mere nested functions instead – they do not capture any variables from their lexical environment. We will see captures next.

## More to Explore

- The ability to store functions in variables doesn't just apply to closures, regular functions can be put in variables and then invoked the same way that closures can: [Example in the playground](#).
  - The linked example also demonstrates that closures that don't capture anything can also coerce to a regular function pointer.

# Capturing

A closure can capture variables from the environment where it was defined.

```
1 fn main() {
2     let max_value = 5;
3     let clamp = |v| {
4         if v > max_value {
5             max_value
6         } else {
7             v
8         }
9     };
10
11     dbg!(clamp(1));
12     dbg!(clamp(3));
13     dbg!(clamp(5));
14     dbg!(clamp(7));
15     dbg!(clamp(10));
16 }
```

## ▼ Speaker Notes

This slide should take about 5 minutes.

- By default, a closure captures values by reference. Here `max_value` is captured by `clamp`, but still available to `main` for printing. Try making `max_value` mutable, changing it, and printing the clamped values again. Why doesn't this work?
- If a closure mutates values, it will capture them by mutable reference. Try adding `max_value += 1` to `clamp`.
- You can force a closure to move values instead of referencing them with the `move` keyword. This can help with lifetimes, for example if the closure must outlive the captured values (more on lifetimes later).

This looks like `move |v| ...`. Try adding this keyword and see if `main` can still access `max_value` after defining `clamp`.

- By default, closures will capture each variable from an outer scope by the least demanding form of access they can (by shared reference if possible, then exclusive reference, then by move). The `move` keyword forces capture by value.

# Closure traits

Closures or lambda expressions have types which cannot be named. However, they implement special `Fn`, `FnMut`, and `FnOnce` traits:

The special type `fn` refers to function pointers - either the address of a function, or a closure that captures nothing.

```

1 | fn apply_and_log(func: impl FnOnce(String) -> String, func_name: &str, input: &str) {
2 |     println!("Calling {func_name}({input}): {}", func(input.to_string()))
3 | }
4 |
5 | fn main() {
6 |     let suffix = "-itis";
7 |     let add_suffix = |x| format!("{x}{suffix}");
8 |     apply_and_log(&add_suffix, "add_suffix", "senior");
9 |     apply_and_log(&add_suffix, "add_suffix", "appenix");
10 |
11 |     let mut v = Vec::new();
12 |     let mut accumulate = |x| {
13 |         v.push(x);
14 |         v.join("/")
15 |     };
16 |     apply_and_log(&mut accumulate, "accumulate", "red");
17 |     apply_and_log(&mut accumulate, "accumulate", "green");
18 |     apply_and_log(&mut accumulate, "accumulate", "blue");
19 |
20 |     let take_and_reverse = |mut prefix: String| {
21 |         prefix.push_str(&v.into_iter().rev().collect::<Vec<_>>().join("/"));
22 |         prefix
23 |     };
24 |     apply_and_log(take_and_reverse, "take_and_reverse", "reversed: ");
25 | }

```

## ▼ Speaker Notes

This slide should take about 10 minutes.

An `Fn` (e.g. `add_suffix`) neither consumes nor mutates captured values. It can be called needing only a shared reference to the closure, which means the closure can be executed repeatedly and even concurrently.

An `FnMut` (e.g. `accumulate`) might mutate captured values. The closure object is accessed via exclusive reference, so it can be called repeatedly but not concurrently.

If you have an `FnOnce` (e.g. `take_and_reverse`), you may only call it once. Doing so consumes the closure and any values captured by move.

`FnMut` is a subtype of `FnOnce`. `Fn` is a subtype of `FnMut` and `FnOnce`. I.e. you can use an `FnMut` wherever an `FnOnce` is called for, and you can use an `Fn` wherever an `FnMut` or `FnOnce` is called for.

When you define a function that takes a closure, you should take `FnOnce` if you can (i.e. you call it once), or `FnMut` else, and last `Fn`. This allows the most flexibility for the caller.

In contrast, when you have a closure, the most flexible you can have is `Fn` (which can be passed to a consumer of any of the 3 closure traits), then `FnMut`, and lastly `FnOnce`.

The compiler also infers `Copy` (e.g. for `add_suffix`) and `Clone` (e.g. `take_and_reverse`), depending on what the closure captures. Function pointers (references to `fn` items) implement `Copy` and `Fn`.

# Exercise: Log Filter

Building on the generic logger from this morning, implement a `Filter` which uses a closure to filter log messages, sending those which pass the filtering predicate to an inner logger.

```
1 pub trait Logger {
2     /// Log a message at the given verbosity level.
3     fn log(&self, verbosity: u8, message: &str);
4 }
5
6 struct StderrLogger;
7
8 impl Logger for StderrLogger {
9     fn log(&self, verbosity: u8, message: &str) {
10         eprintln!("verbosity={verbosity}: {message}");
11     }
12 }
13
14 // TODO: Define and implement `Filter`.
15
16 fn main() {
17     let logger = Filter::new(StderrLogger, |_verbosity, msg| msg.contains("yikes"));
18     logger.log(5, "FYI");
19     logger.log(1, "yikes, something went wrong");
20     logger.log(2, "uhoh");
21 }
```

# Solution

```

1  pub trait Logger {
2      /// Log a message at the given verbosity level.
3      fn log(&self, verbosity: u8, message: &str);
4  }
5
6  struct StderrLogger;
7
8  impl Logger for StderrLogger {
9      fn log(&self, verbosity: u8, message: &str) {
10         eprintln!("verbosity={verbosity}: {message}");
11     }
12 }
13
14 /// Only log messages matching a filtering predicate.
15 struct Filter<L, P> {
16     inner: L,
17     predicate: P,
18 }
19
20 impl<L, P> Filter<L, P>
21 where
22     L: Logger,
23     P: Fn(u8, &str) -> bool,
24 {
25     fn new(inner: L, predicate: P) -> Self {
26         Self { inner, predicate }
27     }
28 }
29 impl<L, P> Logger for Filter<L, P>
30 where
31     L: Logger,
32     P: Fn(u8, &str) -> bool,
33 {
34     fn log(&self, verbosity: u8, message: &str) {
35         if (self.predicate)(verbosity, message) {
36             self.inner.log(verbosity, message);
37         }
38     }
39 }
40
41 fn main() {
42     let logger = Filter::new(StderrLogger, |_verbosity, msg| msg.contains("yikes"));
43     logger.log(5, "FYI");
44     logger.log(1, "yikes, something went wrong");
45     logger.log(2, "uhoh");
46 }

```

# Welcome to Day 3

Today, we will cover:

- Memory management, lifetimes, and the borrow checker: how Rust ensures memory safety.
- Smart pointers: standard library pointer types.

## Schedule

Including 10 minute breaks, this session should take about 2 hours and 20 minutes. It contains:

Segment	Duration
Welcome	3 minutes
Memory Management	1 hour
Smart Pointers	55 minutes

# Memory Management

This segment should take about 1 hour. It contains:

Slide	Duration
Review of Program Memory	5 minutes
Approaches to Memory Management	10 minutes
Ownership	5 minutes
Move Semantics	5 minutes
Clone	2 minutes
Copy Types	5 minutes
Drop	10 minutes
Exercise: Builder Type	20 minutes



# Review of Program Memory

Programs allocate memory in two ways:

- Stack: Continuous area of memory for local variables.
  - Values have fixed sizes known at compile time.
  - Extremely fast: just move a stack pointer.
  - Easy to manage: follows function calls.
  - Great memory locality.
- Heap: Storage of values outside of function calls.
  - Values have dynamic sizes determined at runtime.
  - Slightly slower than the stack: some book-keeping needed.
  - No guarantee of memory locality.

## Example

Creating a `String` puts fixed-sized metadata on the stack and dynamically sized data, the actual string, on the heap:

```
1 fn main() {
2     let s1 = String::from("Hello");
3 }
```

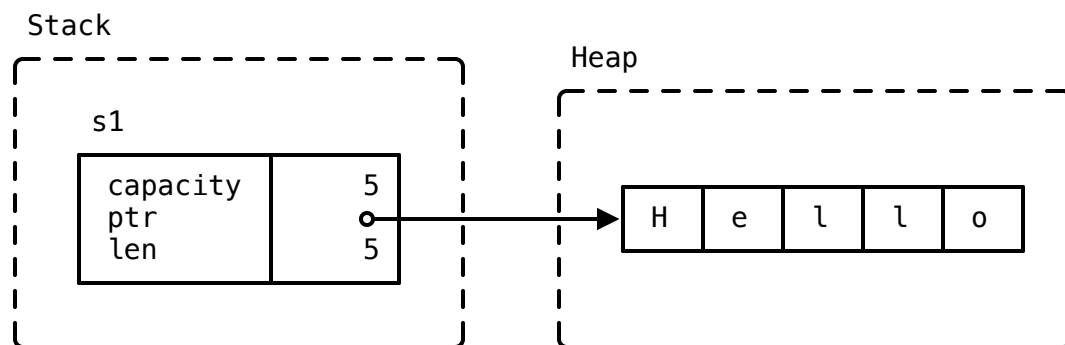

### ▼ Speaker Notes

This slide should take about 5 minutes.

- Mention that a `String` is backed by a `Vec`, so it has a capacity and length and can grow if mutable via reallocation on the heap.

- If students ask about it, you can mention that the underlying memory is heap allocated using the [System Allocator](#) and custom allocators can be implemented using the [Allocator API](#)

## More to Explore

We can inspect the memory layout with `unsafe` Rust. However, you should point out that this is rightfully unsafe!

```
1 fn main() {
2     let mut s1 = String::from("Hello");
3     s1.push(' ');
4     s1.push_str("world");
5     // DON'T DO THIS AT HOME! For educational purposes only.
6     // String provides no guarantees about its layout, so this could lead to
7     // undefined behavior.
8     unsafe {
9         let (capacity, ptr, len): (usize, usize, usize) = std::mem::transmute
10        println!("capacity = {capacity}, ptr = {ptr:#x}, len = {len}");
11    }
12 }
```

# Approaches to Memory Management

Traditionally, languages have fallen into two broad categories:

- Full control via manual memory management: C, C++, Pascal, ...
  - Programmer decides when to allocate or free heap memory.
  - Programmer must determine whether a pointer still points to valid memory.
  - Studies show, programmers make mistakes.
- Full safety via automatic memory management at runtime: Java, Python, Go, Haskell, ...
  - A runtime system ensures that memory is not freed until it can no longer be referenced.
  - Typically implemented with reference counting or garbage collection.

Rust offers a new mix:

---

Full control *and* safety via compile time enforcement of correct memory management.

---

It does this with an explicit ownership concept.

## ▼ *Speaker Notes*

This slide should take about 10 minutes.

This slide is intended to help students coming from other languages to put Rust in context.

- C must manage heap manually with `malloc` and `free`. Common errors include forgetting to call `free`, calling it multiple times for the same pointer, or dereferencing a pointer after the memory it points to has been freed.
- C++ has tools like smart pointers (`unique_ptr`, `shared_ptr`) that take advantage of language guarantees about calling destructors to ensure memory is freed when a function returns. It is still quite easy to mis-use these tools and create similar bugs to C.
- Java, Go, and Python rely on the garbage collector to identify memory that is no longer reachable and discard it. This guarantees that any pointer can be dereferenced, eliminating use-after-free and other classes of bugs. But, GC has a runtime cost and is difficult to tune properly.

Rust's ownership and borrowing model can, in many cases, get the performance of C, with `alloc` and `free` operations precisely where they are required – zero cost. It also provides tools similar to C++'s smart pointers. When required, other options such as reference counting are

available, and there are even crates available to support runtime garbage collection (not covered in this class).

# Ownership

All variable bindings have a *scope* where they are valid and it is an error to use a variable outside its scope:

```
1 struct Point(i32, i32);
2
3 fn main() {
4     {
5         let p = Point(3, 4);
6         dbg!(p.0);
7     }
8     dbg!(p.1);
9 }
```

We say that the variable *owns* the value. Every Rust value has precisely one owner at all times.

At the end of the scope, the variable is *dropped* and the data is freed. A destructor can run here to free up resources.

## ▼ Speaker Notes

This slide should take about 5 minutes.

Students familiar with garbage-collection implementations will know that a garbage collector starts with a set of “roots” to find all reachable memory. Rust’s “single owner” principle is a similar idea.

# Move Semantics

An assignment will transfer *ownership* between variables:

```

1 fn main() {
2     let s1: String = String::from("Hello!");
3     let s2: String = s1;
4     dbg!(s2);
5     // dbg!(s1);
6 }

```

- The assignment of `s1` to `s2` transfers ownership.
- When `s1` goes out of scope, nothing happens: it does not own anything.
- When `s2` goes out of scope, the string data is freed.

Before move to `s2` :

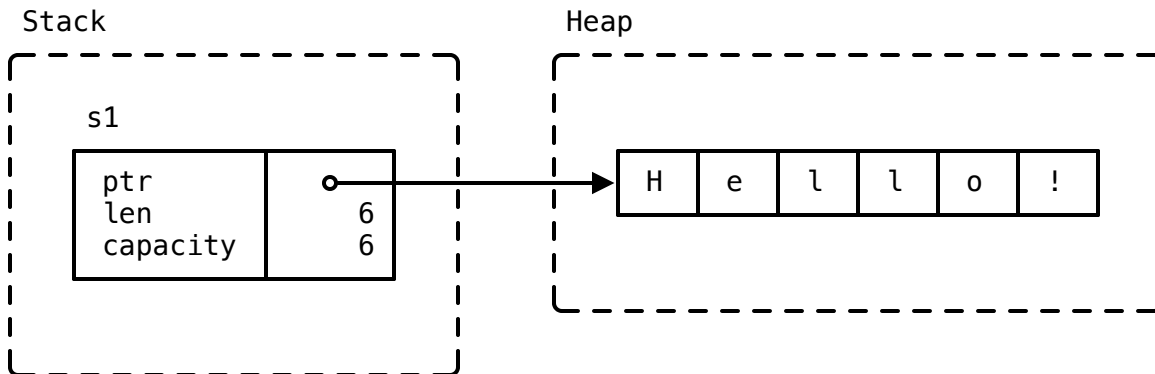

After move to `s2` :

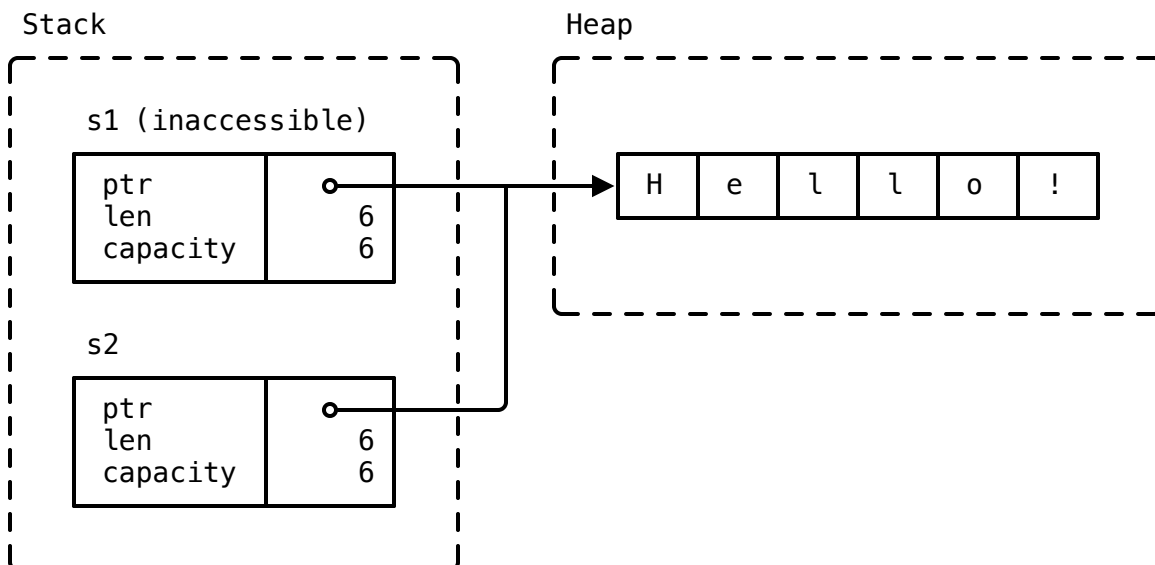

When you pass a value to a function, the value is assigned to the function parameter. This transfers ownership:

```
1 fn say_hello(name: String) {
2     println!("Hello {name}")
3 }
4
5 fn main() {
6     let name = String::from("Alice");
7     say_hello(name);
8     // say_hello(name);
9 }
```

### ▼ Speaker Notes

This slide should take about 5 minutes.

- Mention that this is the opposite of the defaults in C++, which copies by value unless you use `std::move` (and the move constructor is defined!).
- It is only the ownership that moves. Whether any machine code is generated to manipulate the data itself is a matter of optimization, and such copies are aggressively optimized away.
- Simple values (such as integers) can be marked `copy` (see later slides).
- In Rust, clones are explicit (by using `clone`).

In the `say_hello` example:

- With the first call to `say_hello`, `main` gives up ownership of `name`. Afterwards, `name` cannot be used anymore within `main`.
- The heap memory allocated for `name` will be freed at the end of the `say_hello` function.
- `main` can retain ownership if it passes `name` as a reference (`&name`) and if `say_hello` accepts a reference as a parameter.
- Alternatively, `main` can pass a clone of `name` in the first call (`name.clone()`).
- Rust makes it harder than C++ to inadvertently create copies by making move semantics the default, and by forcing programmers to make clones explicit.

## More to Explore

### Defensive Copies in Modern C++

Modern C++ solves this differently:

```
std::string s1 = "Cpp";
std::string s2 = s1; // Duplicate the data in s1.
```

- The heap data from `s1` is duplicated and `s2` gets its own independent copy.
- When `s1` and `s2` go out of scope, they each free their own memory.

Before copy-assignment:

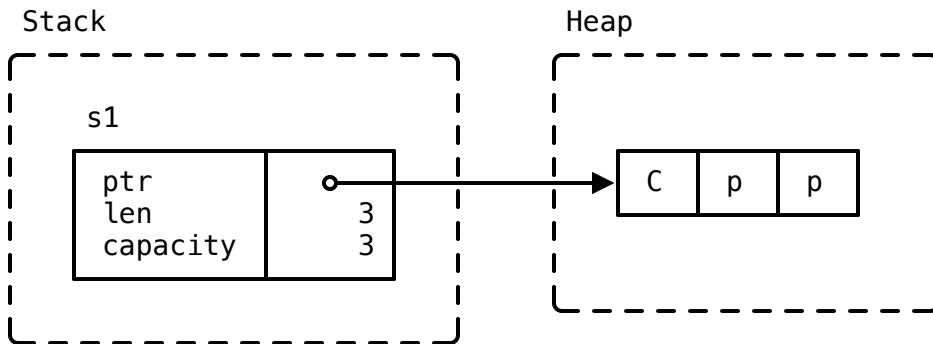

After copy-assignment:

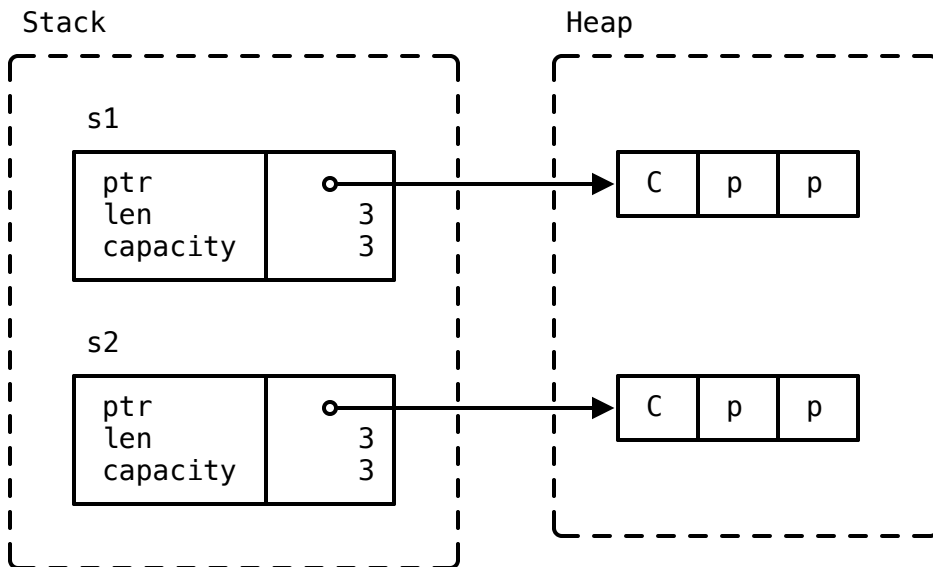

Key points:

- C++ has made a slightly different choice than Rust. Because `=` copies data, the string data has to be cloned. Otherwise we would get a double-free when either string goes out of scope.
- C++ also has `std::move`, which is used to indicate when a value may be moved from. If the example had been `s2 = std::move(s1)`, no heap allocation would take place. After the move, `s1` would be in a valid but unspecified state. Unlike Rust, the programmer is allowed to keep using `s1`.



- Unlike Rust, = in C++ can run arbitrary code as determined by the type which is being copied or moved.

# Clone

Sometimes you *want* to make a copy of a value. The `clone` trait accomplishes this.

```
1 fn say_hello(name: String) {
2     println!("Hello {name}")
3 }
4
5 fn main() {
6     let name = String::from("Alice");
7     say_hello(name.clone());
8     say_hello(name);
9 }
```

## ▼ Speaker Notes

This slide should take about 2 minutes.

- The idea of `clone` is to make it easy to spot where heap allocations are occurring. Look for `.clone()` and a few others like `vec!` or `Box::new`.
- It's common to "clone your way out" of problems with the borrow checker, and return later to try to optimize those clones away.
- `clone` generally performs a deep copy of the value, meaning that if you e.g. clone an array, all of the elements of the array are cloned as well.
- The behavior for `clone` is user-defined, so it can perform custom cloning logic if needed.

# Copy Types

While move semantics are the default, certain types are copied by default:

```

1 fn main() {
2     let x = 42;
3     let y = x;
4     dbg!(x); // would not be accessible if not Copy
5     dbg!(y);
6 }
```

These types implement the `Copy` trait.

You can opt-in your own types to use copy semantics:

```

1 #[derive(Copy, Clone, Debug)]
2 struct Point(i32, i32);
3
4 fn main() {
5     let p1 = Point(3, 4);
6     let p2 = p1;
7     println!("p1: {p1:?}");
8     println!("p2: {p2:?}");
9 }
```

- After the assignment, both `p1` and `p2` own their own data.
- We can also use `p1.clone()` to explicitly copy the data.

## ▼ Speaker Notes

This slide should take about 5 minutes.

Copying and cloning are not the same thing:

- Copying refers to bitwise copies of memory regions and does not work on arbitrary objects.
- Copying does not allow for custom logic (unlike copy constructors in C++).
- Cloning is a more general operation and also allows for custom behavior by implementing the `Clone` trait.
- Copying does not work on types that implement the `Drop` trait.

In the above example, try the following:

- Add a `String` field to `struct Point`. It will not compile because `String` is not a `Copy` type.

- Remove `copy` from the `derive` attribute. The compiler error is now in the `println!` for `p1`.
- Show that it works if you clone `p1` instead.

## More to Explore

- Shared references are `Copy / Clone`, mutable references are not. This is because Rust requires that mutable references be exclusive, so while it's valid to make a copy of a shared reference, creating a copy of a mutable reference would violate Rust's borrowing rules.

# The Drop Trait

Values which implement `Drop` can specify code to run when they go out of scope:

```

1  struct Droppable {
2      name: &'static str,
3  }
4
5  impl Drop for Droppable {
6      fn drop(&mut self) {
7          println!("Dropping {}", self.name);
8      }
9  }
10
11 fn main() {
12     let a = Droppable { name: "a" };
13     {
14         let b = Droppable { name: "b" };
15         {
16             let c = Droppable { name: "c" };
17             let d = Droppable { name: "d" };
18             println!("Exiting innermost block");
19         }
20         println!("Exiting next block");
21     }
22     drop(a);
23     println!("Exiting main");
24 }

```

## ▼ Speaker Notes

This slide should take about 8 minutes.

- Note that `std::mem::drop` is not the same as `std::ops::Drop::drop`.
- Values are automatically dropped when they go out of scope.
- When a value is dropped, if it implements `std::ops::Drop` then its `Drop::drop` implementation will be called.
- All its fields will then be dropped too, whether or not it implements `Drop`.
- `std::mem::drop` is just an empty function that takes any value. The significance is that it takes ownership of the value, so at the end of its scope it gets dropped. This makes it a convenient way to explicitly drop values earlier than they would otherwise go out of scope.
  - This can be useful for objects that do some work on `drop`: releasing locks, closing files, etc.

Discussion points:

- Why doesn't `Drop::drop` take `self`?
  - Short-answer: If it did, `std::mem::drop` would be called at the end of the block, resulting in another call to `Drop::drop`, and a stack overflow!
- Try replacing `drop(a)` with `a.drop()`.

# Exercise: Builder Type

In this example, we will implement a complex data type that owns all of its data. We will use the “builder pattern” to support building a new value piece-by-piece, using convenience functions.

Fill in the missing pieces.

```
1 #[derive(Debug)]
2 enum Language {
3     Rust,
4     Java,
5     Perl,
6 }
7
8 #[derive(Clone, Debug)]
9 struct Dependency {
10     name: String,
11     version_expression: String,
12 }
13
14 /// A representation of a software package.
15 #[derive(Debug)]
16 struct Package {
17     name: String,
18     version: String,
19     authors: Vec<String>,
20     dependencies: Vec<Dependency>,
21     language: Option<Language>,
22 }
23
24 impl Package {
25     /// Return a representation of this package as a dependency, for use in
26     /// building other packages.
27     fn as_dependency(&self) -> Dependency {
28         todo!("1")
29     }
30 }
31
32 /// A builder for a Package. Use `build()` to create the `Package` itself.
33 struct PackageBuilder(Package);
34
35 impl PackageBuilder {
36     fn new(name: impl Into<String>) -> Self {
37         todo!("2")
38     }
39
40     /// Set the package version.
41     fn version(mut self, version: impl Into<String>) -> Self {
42         self.0.version = version.into();
43         self
44     }
45
46     /// Set the package authors.
47     fn authors(mut self, authors: Vec<String>) -> Self {
48         todo!("3")
49     }
50
51     /// Add an additional dependency.
52     fn dependency(mut self, dependency: Dependency) -> Self {
53         todo!("4")
54     }
55 }
```



```
56     /// Set the language. If not set, language defaults to None.
57     fn language(mut self, language: Language) -> Self {
58         todo!("5")
59     }
60
61     fn build(self) -> Package {
62         self.0
63     }
64 }
65
66 fn main() {
67     let base64 = PackageBuilder::new("base64").version("0.13").build();
68     dbg!(&base64);
69     let log =
70         PackageBuilder::new("log").version("0.4").language(Language::Rust).bui
71     dbg!(&log);
72     let serde = PackageBuilder::new("serde")
73         .authors(vec!["djmitche".into()])
74         .version(String::from("4.0"))
75         .dependency(base64.as_dependency())
76         .dependency(log.as_dependency())
77         .build();
78     dbg!(serde);
79 }
```



# Solution

```

1  #[derive(Debug)]
2  enum Language {
3      Rust,
4      Java,
5      Perl,
6  }
7
8  #[derive(Clone, Debug)]
9  struct Dependency {
10     name: String,
11     version_expression: String,
12 }
13
14 /// A representation of a software package.
15 #[derive(Debug)]
16 struct Package {
17     name: String,
18     version: String,
19     authors: Vec<String>,
20     dependencies: Vec<Dependency>,
21     language: Option<Language>,
22 }
23
24 impl Package {
25     /// Return a representation of this package as a dependency, for use in
26     /// building other packages.
27     fn as_dependency(&self) -> Dependency {
28         Dependency {
29             name: self.name.clone(),
30             version_expression: self.version.clone(),
31         }
32     }
33 }
34
35 /// A builder for a Package. Use `build()` to create the `Package` itself.
36 struct PackageBuilder(Package);
37
38 impl PackageBuilder {
39     fn new(name: impl Into<String>) -> Self {
40         Self(Package {
41             name: name.into(),
42             version: "0.1".into(),
43             authors: vec![],
44             dependencies: vec![],
45             language: None,
46         })
47     }
48
49     /// Set the package version.
50     fn version(mut self, version: impl Into<String>) -> Self {
51         self.0.version = version.into();

```

```
52     self
53 }
54
55 /// Set the package authors.
56 fn authors(mut self, authors: Vec<String>) -> Self {
57     self.0.authors = authors;
58     self
59 }
60
61 /// Add an additional dependency.
62 fn dependency(mut self, dependency: Dependency) -> Self {
63     self.0.dependencies.push(dependency);
64     self
65 }
66
67 /// Set the language. If not set, language defaults to None.
68 fn language(mut self, language: Language) -> Self {
69     self.0.language = Some(language);
70     self
71 }
72
73 fn build(self) -> Package {
74     self.0
75 }
76 }
77
78 fn main() {
79     let base64 = PackageBuilder::new("base64").version("0.13").build();
80     dbg!(&base64);
81     let log =
82         PackageBuilder::new("log").version("0.4").language(Language::Rust).build();
83     dbg!(&log);
84     let serde = PackageBuilder::new("serde")
85         .authors(vec!["djmitche".into()])
86         .version(String::from("4.0"))
87         .dependency(base64.as_dependency())
88         .dependency(log.as_dependency())
89         .build();
90     dbg!(serde);
91 }
```

# Smart Pointers

This segment should take about 55 minutes. It contains:

Slide	Duration
Box	10 minutes
Rc	5 minutes
Owned Trait Objects	10 minutes
Exercise: Binary Tree	30 minutes

# Box<T>

`Box` is an owned pointer to data on the heap:

```
1 fn main() {
2     let five = Box::new(5);
3     println!("five: {}", *five);
4 }
```

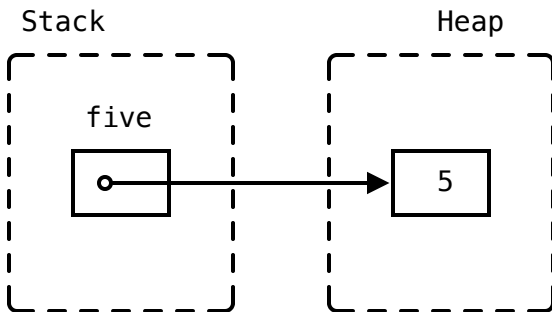

`Box<T>` implements `Deref<Target = T>`, which means that you can [call methods from `T` directly on a `Box<T>`](#).

Recursive data types or data types with dynamic sizes cannot be stored inline without a pointer indirection. `Box` accomplishes that indirection:

```
1 #[derive(Debug)]
2 enum List<T> {
3     /// A non-empty list: first element and the rest of the list.
4     Element(T, Box<List<T>>),
5     /// An empty list.
6     Nil,
7 }
8
9 fn main() {
10     let list: List<i32> =
11         List::Element(1, Box::new(List::Element(2, Box::new(List::Nil))));
12     println!("{list:?}");
13 }
```

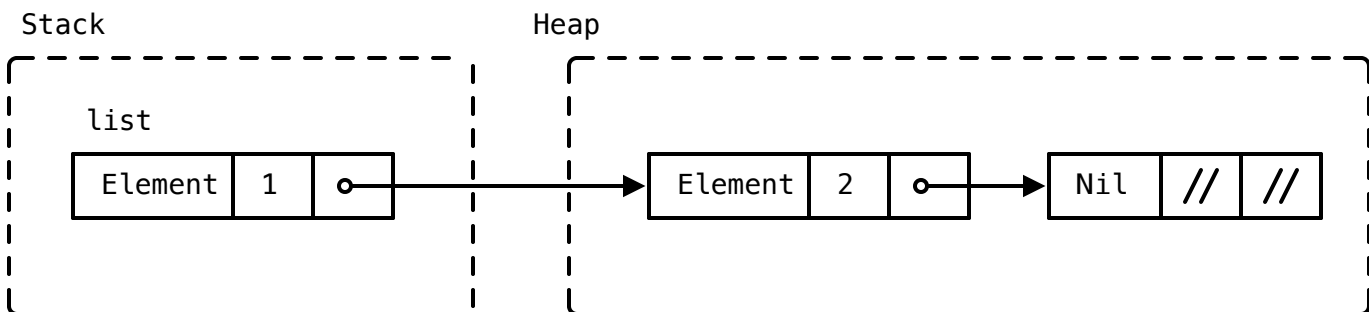

### ▼ *Speaker Notes*

This slide should take about 8 minutes.

- `Box` is like `std::unique_ptr` in C++, except that it's guaranteed to be not null.
- A `Box` can be useful when you:
  - have a type whose size can't be known at compile time, but the Rust compiler wants to know an exact size.
  - want to transfer ownership of a large amount of data. To avoid copying large amounts of data on the stack, instead store the data on the heap in a `Box` so only the pointer is moved.
- If `Box` was not used and we attempted to embed a `List` directly into the `List`, the compiler would not be able to compute a fixed size for the struct in memory (the `List` would be of infinite size).
- `Box` solves this problem as it has the same size as a regular pointer and just points at the next element of the `List` in the heap.
- Remove the `Box` in the `List` definition and show the compiler error. We get the message "recursive without indirection", because for data recursion, we have to use indirection, a `Box` or reference of some kind, instead of storing the value directly.
- Though `Box` looks like `std::unique_ptr` in C++, it cannot be empty/null. This makes `Box` one of the types that allow the compiler to optimize storage of some enums (the "niche optimization").

# Rc

`Rc` is a reference-counted shared pointer. Use this when you need to refer to the same data from multiple places:

```

1 use std::rc::Rc;
2
3 fn main() {
4     let a = Rc::new(10);
5     let b = Rc::clone(&a);
6
7     dbg!(a);
8     dbg!(b);
9 }
```

Each `Rc` points to the same shared data structure, containing strong and weak pointers and the value:

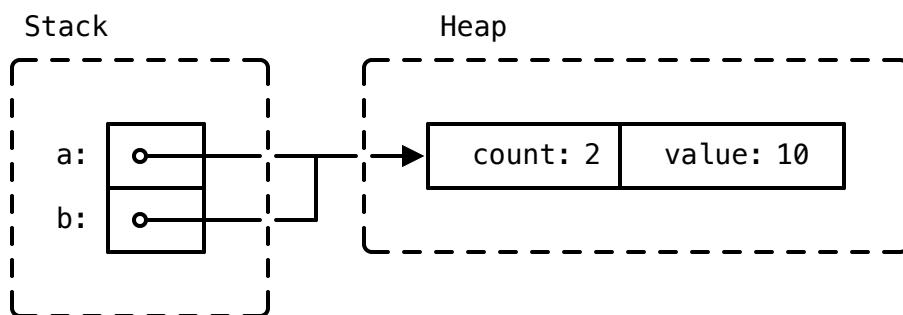

- See [Arc](#) and [Mutex](#) if you are in a multi-threaded context.
- You can *downgrade* a shared pointer into a [Weak](#) pointer to create cycles that will get dropped.

## ▼ Speaker Notes

This slide should take about 5 minutes.

- `Rc`'s count ensures that its contained value is valid for as long as there are references.
- `Rc` in Rust is like `std::shared_ptr` in C++.
- `Rc::clone` is cheap: it creates a pointer to the same allocation and increases the reference count. Does not make a deep clone and can generally be ignored when looking for performance issues in code.
- `make_mut` actually clones the inner value if necessary (“clone-on-write”) and returns a mutable reference.
- Use `Rc::strong_count` to check the reference count.



- `Rc::downgrade` gives you a *weakly reference-counted* object to create cycles that will be dropped properly (likely in combination with `RefCell`).

# Owned Trait Objects

We previously saw how trait objects can be used with references, e.g. `&dyn Pet`. However, we can also use trait objects with smart pointers like `Box` to create an owned trait object: `Box<dyn Pet>`.

```
1 struct Dog {
2     name: String,
3     age: i8,
4 }
5 struct Cat {
6     lives: i8,
7 }
8
9 trait Pet {
10     fn talk(&self) -> String;
11 }
12
13 impl Pet for Dog {
14     fn talk(&self) -> String {
15         format!("Woof, my name is {}!", self.name)
16     }
17 }
18
19 impl Pet for Cat {
20     fn talk(&self) -> String {
21         String::from("Miau!")
22     }
23 }
24
25 fn main() {
26     let pets: Vec<Box<dyn Pet>> = vec![
27         Box::new(Cat { lives: 9 }),
28         Box::new(Dog { name: String::from("Fido"), age: 5 }),
29     ];
30     for pet in pets {
31         println!("Hello, who are you? {}", pet.talk());
32     }
33 }
```

Memory layout after allocating `pets` :

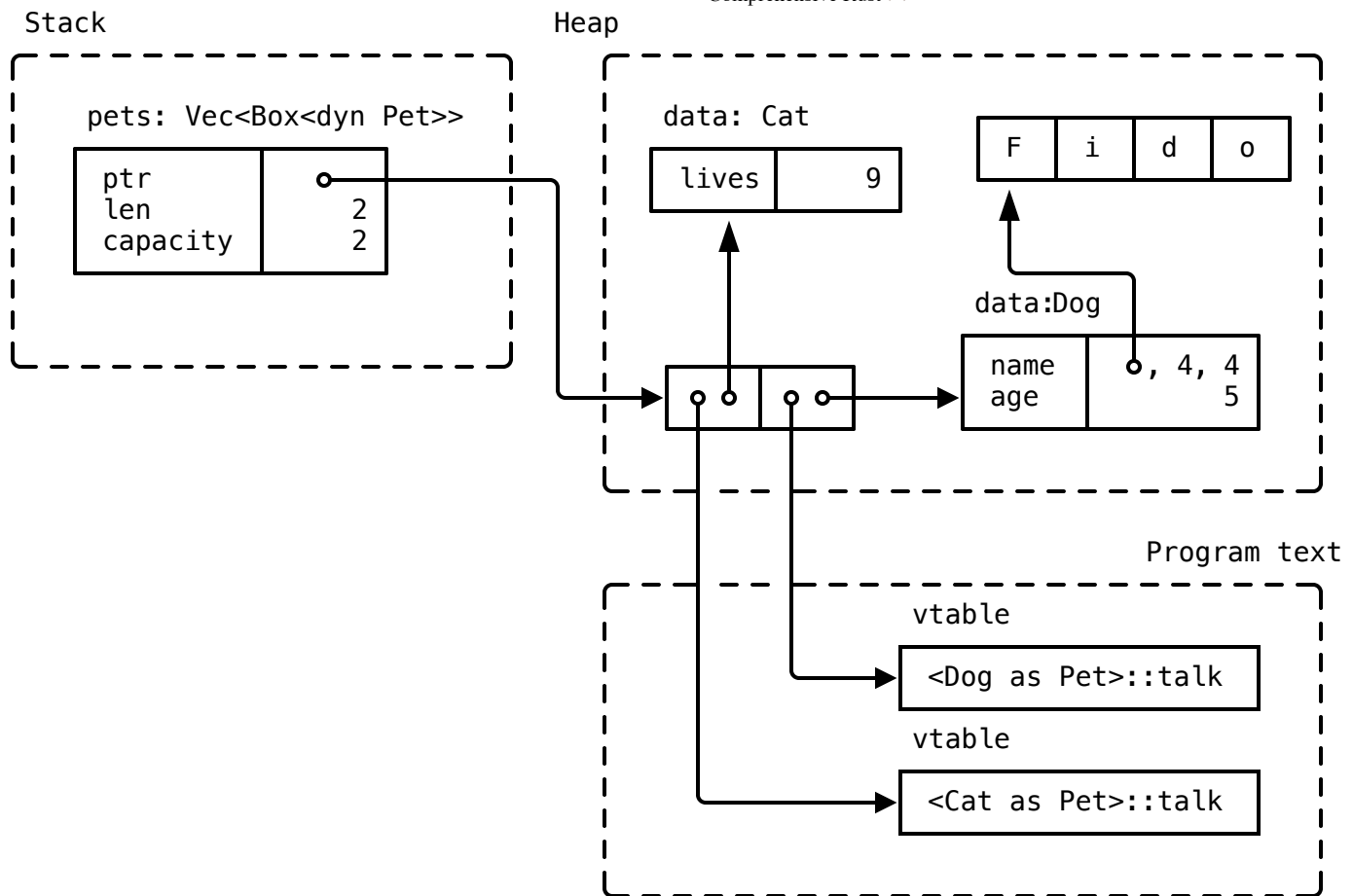

### ▼ Speaker Notes

This slide should take about 10 minutes.

- Types that implement a given trait may be of different sizes. This makes it impossible to have things like `Vec<dyn Pet>` in the example above.
- `dyn Pet` is a way to tell the compiler about a dynamically sized type that implements `Pet`.
- In the example, `pets` is allocated on the stack and the vector data is on the heap. The two vector elements are *fat pointers*:
  - A fat pointer is a double-width pointer. It has two components: a pointer to the actual object and a pointer to the [virtual method table](#) (vtable) for the `Pet` implementation of that particular object.
  - The data for the `Dog` named Fido is the `name` and `age` fields. The `Cat` has a `lives` field.
- Compare these outputs in the above example:

```
println!("{}", std::mem::size_of::<Dog>(), std::mem::size_of::<Cat>());  
println!("{}", std::mem::size_of::&<Dog>(), std::mem::size_of::&<Cat>());  
println!("{}", std::mem::size_of::<&dyn Pet>());  
println!("{}", std::mem::size_of::<Box<dyn Pet>>());
```

# Exercise: Binary Tree

A binary tree is a tree-type data structure where every node has two children (left and right). We will create a tree where each node stores a value. For a given node  $N$ , all nodes in a  $N$ 's left subtree contain smaller values, and all nodes in  $N$ 's right subtree will contain larger values.

Implement the following types, so that the given tests pass.

Extra Credit: implement an iterator over a binary tree that returns the values in order.

```

1  ///  
2  #[derive(Debug)]  
3  struct Node<T: Ord> {  
4      value: T,  
5      left: Subtree<T>,  
6      right: Subtree<T>,  
7  }  
8  
9  ///  
10 #[derive(Debug)]  
11 struct Subtree<T: Ord>(Option<Box<Node<T>>>);  
12  
13 ///  
14 ///  
15 ///  
16 #[derive(Debug)]  
17 pub struct BinaryTree<T: Ord> {  
18     root: Subtree<T>,  
19 }  
20  
21 impl<T: Ord> BinaryTree<T> {  
22     fn new() -> Self {  
23         Self { root: Subtree::new() }  
24     }  
25  
26     fn insert(&mut self, value: T) {  
27         self.root.insert(value);  
28     }  
29  
30     fn has(&self, value: &T) -> bool {  
31         self.root.has(value)  
32     }  
33  
34     fn len(&self) -> usize {  
35         self.root.len()  
36     }  
37 }  
38  
39 // Implement `new`, `insert`, `len`, and `has` for `Subtree`.  
40  
41 #[cfg(test)]  
42 mod tests {  
43     use super::*;  
44  
45     #[test]  
46     fn len() {  
47         let mut tree = BinaryTree::new();  
48         assert_eq!(tree.len(), 0);  
49         tree.insert(2);  
50         assert_eq!(tree.len(), 1);  
51         tree.insert(1);  
52         assert_eq!(tree.len(), 2);  
53         tree.insert(2); // not a unique item  
54         assert_eq!(tree.len(), 2);  
55         tree.insert(2);

```

```
55     tree.insert(0),
56     assert_eq!(tree.len(), 3);
57 }
58
59 #[test]
60 fn has() {
61     let mut tree = BinaryTree::new();
62     fn check_has(tree: &BinaryTree<i32>, exp: &[bool]) {
63         let got: Vec<bool> =
64             (0..exp.len()).map(|i| tree.has(&(i as i32))).collect();
65         assert_eq!(&got, exp);
66     }
67
68     check_has(&tree, &[false, false, false, false, false]);
69     tree.insert(0);
70     check_has(&tree, &[true, false, false, false, false]);
71     tree.insert(4);
72     check_has(&tree, &[true, false, false, false, true]);
73     tree.insert(4);
74     check_has(&tree, &[true, false, false, false, true]);
75     tree.insert(3);
76     check_has(&tree, &[true, false, false, true, true]);
77 }
78
79 #[test]
80 fn unbalanced() {
81     let mut tree = BinaryTree::new();
82     for i in 0..100 {
83         tree.insert(i);
84     }
85     assert_eq!(tree.len(), 100);
86     assert!(tree.has(&50));
87 }
88 }
```





# Solution

```

1 use std::cmp::Ordering;
2
3 /// A node in the binary tree.
4 #[derive(Debug)]
5 struct Node<T: Ord> {
6     value: T,
7     left: Subtree<T>,
8     right: Subtree<T>,
9 }
10
11 /// A possibly-empty subtree.
12 #[derive(Debug)]
13 struct Subtree<T: Ord>(Option<Box<Node<T>>>);
14
15 /// A container storing a set of values, using a binary tree.
16 ///
17 /// If the same value is added multiple times, it is only stored once.
18 #[derive(Debug)]
19 pub struct BinaryTree<T: Ord> {
20     root: Subtree<T>,
21 }
22
23 impl<T: Ord> BinaryTree<T> {
24     fn new() -> Self {
25         Self { root: Subtree::new() }
26     }
27
28     fn insert(&mut self, value: T) {
29         self.root.insert(value);
30     }
31
32     fn has(&self, value: &T) -> bool {
33         self.root.has(value)
34     }
35
36     fn len(&self) -> usize {
37         self.root.len()
38     }
39 }
40
41 impl<T: Ord> Subtree<T> {
42     fn new() -> Self {
43         Self(None)
44     }
45
46     fn insert(&mut self, value: T) {
47         match &mut self.0 {
48             None => self.0 = Some(Box::new(Node::new(value))),
49             Some(n) => match value.cmp(&n.value) {
50                 Ordering::Less => n.left.insert(value),
51                 Ordering::Equal => {}

```

```

52         Ordering::Greater => n.right.insert(value),
53     },
54 }
55 }
56
57 fn has(&self, value: &T) -> bool {
58     match &self.0 {
59         None => false,
60         Some(n) => match value.cmp(&n.value) {
61             Ordering::Less => n.left.has(value),
62             Ordering::Equal => true,
63             Ordering::Greater => n.right.has(value),
64         },
65     }
66 }
67
68 fn len(&self) -> usize {
69     match &self.0 {
70         None => 0,
71         Some(n) => 1 + n.left.len() + n.right.len(),
72     }
73 }
74 }
75
76 impl<T: Ord> Node<T> {
77     fn new(value: T) -> Self {
78         Self { value, left: Subtree::new(), right: Subtree::new() }
79     }
80 }
81
82 #[cfg(test)]
83 mod tests {
84     use super::*;
85
86     #[test]
87     fn len() {
88         let mut tree = BinaryTree::new();
89         assert_eq!(tree.len(), 0);
90         tree.insert(2);
91         assert_eq!(tree.len(), 1);
92         tree.insert(1);
93         assert_eq!(tree.len(), 2);
94         tree.insert(2); // not a unique item
95         assert_eq!(tree.len(), 2);
96         tree.insert(3);
97         assert_eq!(tree.len(), 3);
98     }
99
100     #[test]
101     fn has() {
102         let mut tree = BinaryTree::new();
103         fn check_has(tree: &BinaryTree<i32>, exp: &[bool]) {
104             let got: Vec<bool> =
105                 (0..exp.len()).map(|i| tree.has(&(i as i32))).collect();
106             assert_eq!(got, exp);

```

```
100         assert_eq!(actual, exp),
107     }
108
109     check_has(&tree, &[false, false, false, false, false]);
110     tree.insert(0);
111     check_has(&tree, &[true, false, false, false, false]);
112     tree.insert(4);
113     check_has(&tree, &[true, false, false, false, true]);
114     tree.insert(4);
115     check_has(&tree, &[true, false, false, false, true]);
116     tree.insert(3);
117     check_has(&tree, &[true, false, false, true, true]);
118 }
119
120 #[test]
121 fn unbalanced() {
122     let mut tree = BinaryTree::new();
123     for i in 0..100 {
124         tree.insert(i);
125     }
126     assert_eq!(tree.len(), 100);
127     assert!(tree.has(&50));
128 }
129 }
```

# Welcome Back

Including 10 minute breaks, this session should take about 1 hour and 55 minutes. It contains:

Segment	Duration
Borrowing	55 minutes
Lifetimes	50 minutes

# Borrowing

This segment should take about 55 minutes. It contains:

Slide	Duration
Borrowing a Value	10 minutes
Borrow Checking	10 minutes
Borrow Errors	3 minutes
Interior Mutability	10 minutes
Exercise: Health Statistics	20 minutes

# Borrowing a Value

As we saw before, instead of transferring ownership when calling a function, you can let a function *borrow* the value:

```
1 #[derive(Debug)]
2 struct Point(i32, i32);
3
4 fn add(p1: &Point, p2: &Point) -> Point {
5     Point(p1.0 + p2.0, p1.1 + p2.1)
6 }
7
8 fn main() {
9     let p1 = Point(3, 4);
10    let p2 = Point(10, 20);
11    let p3 = add(&p1, &p2);
12    println!("{p1:?} + {p2:?} = {p3:?}");
13 }
```

- The `add` function *borrow*s two points and returns a new point.
- The caller retains ownership of the inputs.

## ▼ Speaker Notes

This slide should take about 10 minutes.

This slide is a review of the material on references from day 1, expanding slightly to include function arguments and return values.

# More to Explore

Notes on stack returns and inlining:

- Demonstrate that the return from `add` is cheap because the compiler can eliminate the copy operation, by inlining the call to `add` into `main`. Change the above code to print stack addresses and run it on the [Playground](#) or look at the assembly in [Godbolt](#). In the “DEBUG” optimization level, the addresses should change, while they stay the same when changing to the “RELEASE” setting:

```
1 #[derive(Debug)]
2 struct Point(i32, i32);
3
4 fn add(p1: &Point, p2: &Point) -> Point {
5     let p = Point(p1.0 + p2.0, p1.1 + p2.1);
6     println!("&p.0: {:p}", &p.0);
7     p
8 }
9
10 pub fn main() {
11     let p1 = Point(3, 4);
12     let p2 = Point(10, 20);
13     let p3 = add(&p1, &p2);
14     println!("&p3.0: {:p}", &p3.0);
15     println!("{p1:?} + {p2:?} = {p3:?}");
16 }
```

- The Rust compiler can do automatic inlining, that can be disabled on a function level with `#[inline(never)]`.
- Once disabled, the printed address will change on all optimization levels. Looking at Godbolt or Playground, one can see that in this case, the return of the value depends on the ABI, e.g. on amd64 the two i32 that is making up the point will be returned in 2 registers (eax and edx).

# Borrow Checking

Rust's *borrow checker* puts constraints on the ways you can borrow values. We've already seen that a reference cannot *outlive* the value it borrows:

```

1 |fn main() {
2 |    let x_ref = {
3 |        let x = 10;
4 |        &x
5 |    };
6 |    dbg!(x_ref);
7 | }
```

There's also a second main rule that the borrow checker enforces: The *aliasing* rule. For a given value, at any time:

- You can have one or more shared references to the value, *or*
- You can have exactly one exclusive reference to the value.

```

1 |fn main() {
2 |    let mut a: i32 = 10;
3 |    let b: &i32 = &a;
4 |
5 |    {
6 |        let c: &mut i32 = &mut a;
7 |        *c = 20;
8 |    }
9 |
10 |    dbg!(a);
11 |    dbg!(b);
12 | }
```

## ▼ Speaker Notes

This slide should take about 10 minutes.

- The “outlives” rule was demonstrated previously when we first looked at references. We review it here to show students that the borrow checking is following a few different rules to validate borrowing.
- The above code does not compile because `a` is borrowed as mutable (through `c`) and as immutable (through `b`) at the same time.
  - Note that the requirement is that conflicting references not *exist* at the same point. It does not matter where the reference is dereferenced. Try commenting out `*c = 20` and show that the compiler error still occurs even if we never use `c`.
  - Note that the intermediate reference `c` isn't necessary to trigger a borrow conflict. Replace `c` with a direct mutation of `a` and demonstrate that this produces a



similar error. This is because direct mutation of a value effectively creates a temporary mutable reference.

- Move the `dbg!` statement for `b` before the scope that introduces `c` to make the code compile.
  - After that change, the compiler realizes that `b` is only ever used before the new mutable borrow of `a` through `c`. This is a feature of the borrow checker called “non-lexical lifetimes”.

## More to Explore

- Technically multiple mutable references to a piece of data can exist at the same time via re-borrowing. This is what allows you to pass a mutable reference into a function without invalidating the original reference. [This playground example](#) demonstrates that behavior.
- Rust uses the exclusive reference constraint to ensure that data races do not occur in multi-threaded code, since only one thread can have mutable access to a piece of data at a time.
- Rust also uses this constraint to optimize code. For example, a value behind a shared reference can be safely cached in a register for the lifetime of that reference.
- Fields of a struct can be borrowed independently of each other, but calling a method on a struct will borrow the whole struct, potentially invalidating references to individual fields. See [this playground snippet](#) for an example of this.

# Borrow Errors

As a concrete example of how these borrowing rules prevent memory errors, consider the case of modifying a collection while there are references to its elements:

```
1 fn main() {
2     let mut vec = vec![1, 2, 3, 4, 5];
3     let elem = &vec[2];
4     vec.push(6);
5     dbg!(elem);
6 }
```

Similarly, consider the case of iterator invalidation:

```
1 fn main() {
2     let mut vec = vec![1, 2, 3, 4, 5];
3     for elem in &vec {
4         vec.push(elem * 2);
5     }
6 }
```

## ▼ *Speaker Notes*

This slide should take about 3 minutes.

- In both of these cases, modifying the collection by pushing new elements into it can potentially invalidate existing references to the collection's elements if the collection has to reallocate.

# Interior Mutability

In some situations, it's necessary to modify data behind a shared (read-only) reference. For example, a shared data structure might have an internal cache, and wish to update that cache from read-only methods.

The “interior mutability” pattern allows exclusive (mutable) access behind a shared reference. The standard library provides several ways to do this, all while still ensuring safety, typically by performing a runtime check.

## ▼ *Speaker Notes*

This slide and its sub-slides should take about 10 minutes.

The main thing to take away from this slide is that Rust provides *safe* ways to modify data behind a shared reference. There are a variety of ways to ensure that safety, and the next sub-slides present a few of them.

# Cell

`Cell` wraps a value and allows getting or setting the value using only a shared reference to the `Cell`. However, it does not allow any references to the inner value. Since there are no references, borrowing rules cannot be broken.

```
1 use std::cell::Cell;
2
3 fn main() {
4     // Note that `cell` is NOT declared as mutable.
5     let cell = Cell::new(5);
6
7     cell.set(123);
8     dbg!(cell.get());
9 }
```

## ▼ Speaker Notes

- `Cell` is a simple means to ensure safety: it has a `set` method that takes `&self`. This needs no runtime check, but requires moving values, which can have its own cost.

# RefCell

`RefCell` allows accessing and mutating a wrapped value by providing alternative types `Ref` and `RefMut` that emulate `&T / &mut T` without actually being Rust references.

These types perform dynamic checks using a counter in the `RefCell` to prevent existence of a `RefMut` alongside another `Ref / RefMut`.

By implementing `Deref` (and `DerefMut` for `RefMut`), these types allow calling methods on the inner value without allowing references to escape.

```
1 use std::cell::RefCell;
2
3 fn main() {
4     // Note that `cell` is NOT declared as mutable.
5     let cell = RefCell::new(5);
6
7     {
8         let mut cell_ref = cell.borrow_mut();
9         *cell_ref = 123;
10
11         // This triggers an error at runtime.
12         // let other = cell.borrow();
13         // println!("{}", *other);
14     }
15
16     println!("{cell:?}");
17 }
```

## ▼ Speaker Notes

- `RefCell` enforces Rust's usual borrowing rules (either multiple shared references or a single exclusive reference) with a runtime check. In this case, all borrows are very short and never overlap, so the checks always succeed.
- The extra block in the example is to end the borrow created by the call to `borrow_mut` before we print the cell. Trying to print a borrowed `RefCell` just shows the message `"{borrowed}"`.

## More to Explore

There are also `onceCell` and `onceLock`, which allow initialization on first use. Making these useful requires some more knowledge than students have at this time.

# Exercise: Health Statistics

You're working on implementing a health-monitoring system. As part of that, you need to keep track of users' health statistics.

You'll start with a stubbed function in an `impl` block as well as a `User` struct definition. Your goal is to implement the stubbed out method on the `User` struct defined in the `impl` block.

Copy the code below to <https://play.rust-lang.org/> and fill in the missing method:

```

1 |
2 | #![allow(dead_code)]
3 | pub struct User {
4 |     name: String,
5 |     age: u32,
6 |     height: f32,
7 |     visit_count: u32,
8 |     last_blood_pressure: Option<(u32, u32)>,
9 | }
10 |
11 | pub struct Measurements {
12 |     height: f32,
13 |     blood_pressure: (u32, u32),
14 | }
15 |
16 | pub struct HealthReport<'a> {
17 |     patient_name: &'a str,
18 |     visit_count: u32,
19 |     height_change: f32,
20 |     blood_pressure_change: Option<(i32, i32)>,
21 | }
22 |
23 | impl User {
24 |     pub fn new(name: String, age: u32, height: f32) -> Self {
25 |         Self { name, age, height, visit_count: 0, last_blood_pressure: None }
26 |     }
27 |
28 |     pub fn visit_doctor(&mut self, measurements: Measurements) -> HealthReport
29 |         todo!("Update a user's statistics based on measurements from a visit to
30 |     }
31 | }
32 |
33 | #[test]
34 | fn test_visit() {
35 |     let mut bob = User::new(String::from("Bob"), 32, 155.2);
36 |     assert_eq!(bob.visit_count, 0);
37 |     let report =
38 |         bob.visit_doctor(Measurements { height: 156.1, blood_pressure: (120, 80) });
39 |     assert_eq!(report.patient_name, "Bob");
40 |     assert_eq!(report.visit_count, 1);
41 |     assert_eq!(report.blood_pressure_change, None);
42 |     assert!((report.height_change - 0.9).abs() < 0.00001);
43 |
44 |     let report =
45 |         bob.visit_doctor(Measurements { height: 156.1, blood_pressure: (115, 70) });
46 |
47 |     assert_eq!(report.visit_count, 2);
48 |     assert_eq!(report.blood_pressure_change, Some((-5, -4)));
49 |     assert_eq!(report.height_change, 0.0);
50 | }

```





# Solution

```

1 |
2 #![allow(dead_code)]
3 pub struct User {
4     name: String,
5     age: u32,
6     height: f32,
7     visit_count: u32,
8     last_blood_pressure: Option<(u32, u32)>,
9 }
10
11 pub struct Measurements {
12     height: f32,
13     blood_pressure: (u32, u32),
14 }
15
16 pub struct HealthReport<'a> {
17     patient_name: &'a str,
18     visit_count: u32,
19     height_change: f32,
20     blood_pressure_change: Option<(i32, i32)>,
21 }
22
23 impl User {
24     pub fn new(name: String, age: u32, height: f32) -> Self {
25         Self { name, age, height, visit_count: 0, last_blood_pressure: None }
26     }
27
28     pub fn visit_doctor(&mut self, measurements: Measurements) -> HealthReport
29     self.visit_count += 1;
30     let bp = measurements.blood_pressure;
31     let report = HealthReport {
32         patient_name: &self.name,
33         visit_count: self.visit_count,
34         height_change: measurements.height - self.height,
35         blood_pressure_change: match self.last_blood_pressure {
36             Some(lbp) => {
37                 Some((bp.0 as i32 - lbp.0 as i32, bp.1 as i32 - lbp.1 as i.
38             }
39             None => None,
40         },
41     };
42     self.height = measurements.height;
43     self.last_blood_pressure = Some(bp);
44     report
45 }
46 }
47
48 #[test]
49 fn test_visit() {
50     let mut bob = User::new(String::from("Bob"), 32, 155.2);
51     assert_eq!(bob.visit_count, 0);

```

```
52     let report =
53         bob.visit_doctor(Measurements { height: 156.1, blood_pressure: (120, 80) });
54     assert_eq!(report.patient_name, "Bob");
55     assert_eq!(report.visit_count, 1);
56     assert_eq!(report.blood_pressure_change, None);
57     assert!((report.height_change - 0.9).abs() < 0.00001);
58
59     let report =
60         bob.visit_doctor(Measurements { height: 156.1, blood_pressure: (115, 70) });
61
62     assert_eq!(report.visit_count, 2);
63     assert_eq!(report.blood_pressure_change, Some((-5, -4)));
64     assert_eq!(report.height_change, 0.0);
65 }
```

# Lifetimes

This segment should take about 50 minutes. It contains:

Slide	Duration
Lifetime Annotations	10 minutes
Lifetime Elision	5 minutes
Lifetimes in Data Structures	5 minutes
Exercise: Protobuf Parsing	30 minutes

# Lifetime Annotations

A reference has a *lifetime*, which must not “outlive” the value it refers to. This is verified by the borrow checker.

The lifetime can be implicit - this is what we have seen so far. Lifetimes can also be explicit: `&'a Point`, `&'document str`. Lifetimes start with `'` and `'a` is a typical default name. Read `&'a Point` as “a borrowed `Point` which is valid for at least the lifetime `a`”.

Only ownership, not lifetime annotations, control when values are destroyed and determine the concrete lifetime of a given value. The borrow checker just validates that borrows never extend beyond the concrete lifetime of the value.

Explicit lifetime annotations, like types, are required on function signatures (but can be elided in common cases). These provide information for inference at callsites and within the function body, helping the borrow checker to do its job.

```

1  #[derive(Debug)]
2  struct Point(i32, i32);
3
4  fn left_most(p1: &Point, p2: &Point) -> &Point {
5      if p1.0 < p2.0 {
6          p1
7      } else {
8          p2
9      }
10 }
11
12 fn main() {
13     let p1: Point = Point(10, 10);
14     let p2: Point = Point(20, 20);
15     let p3 = left_most(&p1, &p2); // What is the lifetime of p3?
16     dbg!(p3);
17 }

```

## ▼ Speaker Notes

This slide should take about 10 minutes.

In this example, the compiler does not know what lifetime to infer for `p3`. Looking inside the function body shows that it can only safely assume that `p3`'s lifetime is the shorter of `p1` and `p2`. But just like types, Rust requires explicit annotations of lifetimes on function arguments and return values.

Add `'a` appropriately to `left_most`:

```
fn left_most<'a>(p1: &'a Point, p2: &'a Point) -> &'a Point {
```

This says there is some lifetime 'a which both p1 and p2 outlive, and which outlives the return value. The borrow checker verifies this within the function body, and uses this information in main to determine a lifetime for p3 .

Try dropping p2 in main before printing p3 .

# Lifetimes in Function Calls

Lifetimes for function arguments and return values must be fully specified, but Rust allows lifetimes to be elided in most cases with [a few simple rules](#). This is not inference – it is just a syntactic shorthand.

- Each argument which does not have a lifetime annotation is given one.
- If there is only one argument lifetime, it is given to all un-annotated return values.
- If there are multiple argument lifetimes, but the first one is for `self`, that lifetime is given to all un-annotated return values.

```

1  #[derive(Debug)]
2  struct Point(i32, i32);
3
4  fn cab_distance(p1: &Point, p2: &Point) -> i32 {
5      (p1.0 - p2.0).abs() + (p1.1 - p2.1).abs()
6  }
7
8  fn find_nearest<'a>(points: &'a [Point], query: &Point) -> Option<&'a Point> {
9      let mut nearest = None;
10     for p in points {
11         if let Some((_, nearest_dist)) = nearest {
12             let dist = cab_distance(p, query);
13             if dist < nearest_dist {
14                 nearest = Some((p, dist));
15             }
16         } else {
17             nearest = Some((p, cab_distance(p, query)));
18         }
19     }
20     nearest.map(|(p, _)| p)
21 }
22
23 fn main() {
24     let points = &[Point(1, 0), Point(1, 0), Point(-1, 0), Point(0, -1)];
25     let nearest = {
26         let query = Point(0, 2);
27         find_nearest(points, &Point(0, 2))
28     };
29     println!("{:?}", nearest);
30 }

```

## ▼ Speaker Notes

This slide should take about 5 minutes.

In this example, `cab_distance` is trivially elided.

The `nearest` function provides another example of a function with multiple references in its arguments that requires explicit annotation. In `main`, the return value is allowed to outlive the query.

Try adjusting the signature to “lie” about the lifetimes returned:

```
fn find_nearest<'a, 'q>(points: &'a [Point], query: &'q Point) -> Option<&'q Point> {
```

This won't compile, demonstrating that the annotations are checked for validity by the compiler. Note that this is not the case for raw pointers (`unsafe`), and this is a common source of errors with `unsafe Rust`.

Students may ask when to use lifetimes. Rust borrows *always* have lifetimes. Most of the time, elision and type inference mean these don't need to be written out. In more complicated cases, lifetime annotations can help resolve ambiguity. Often, especially when prototyping, it's easier to just work with owned data by cloning values where necessary.



# Lifetimes in Data Structures

If a data type stores borrowed data, it must be annotated with a lifetime:

```
1  #[derive(Debug)]
2  enum HighlightColor {
3      Pink,
4      Yellow,
5  }
6
7  #[derive(Debug)]
8  struct Highlight<'document> {
9      slice: &'document str,
10     color: HighlightColor,
11 }
12
13 fn main() {
14     let doc = String::from("The quick brown fox jumps over the lazy dog.");
15     let noun = Highlight { slice: &doc[16..19], color: HighlightColor::Yellow };
16     let verb = Highlight { slice: &doc[20..25], color: HighlightColor::Pink };
17     // drop(doc);
18     dbg!(noun);
19     dbg!(verb);
20 }
```

## ▼ Speaker Notes

This slide should take about 5 minutes.

- In the above example, the annotation on `Highlight` enforces that the data underlying the contained `&str` lives at least as long as any instance of `Highlight` that uses that data. A struct cannot live longer than the data it references.
- If `doc` is dropped before the end of the lifetime of `noun` or `verb`, the borrow checker throws an error.
- Types with borrowed data force users to hold on to the original data. This can be useful for creating lightweight views, but it generally makes them somewhat harder to use.
- When possible, make data structures own their data directly.
- Some structs with multiple references inside can have more than one lifetime annotation. This can be necessary if there is a need to describe lifetime relationships between the references themselves, in addition to the lifetime of the struct itself. Those are very advanced use cases.

# Exercise: Protobuf Parsing

In this exercise, you will build a parser for the [protobuf binary encoding](#). Don't worry, it's simpler than it seems! This illustrates a common parsing pattern, passing slices of data. The underlying data itself is never copied.

Fully parsing a protobuf message requires knowing the types of the fields, indexed by their field numbers. That is typically provided in a `proto` file. In this exercise, we'll encode that information into `match` statements in functions that get called for each field.

We'll use the following proto:

```
message PhoneNumber {
  optional string number = 1;
  optional string type = 2;
}

message Person {
  optional string name = 1;
  optional int32 id = 2;
  repeated PhoneNumber phones = 3;
}
```

## Messages

A proto message is encoded as a series of fields, one after the next. Each is implemented as a “tag” followed by the value. The tag contains a field number (e.g., `2` for the `id` field of a `Person` message) and a wire type defining how the payload should be determined from the byte stream. These are combined into a single integer, as decoded in `unpack_tag` below.

## Varint

Integers, including the tag, are represented with a variable-length encoding called VARINT. Luckily, `parse_varint` is defined for you below.

## Wire Types

Proto defines several wire types, only two of which are used in this exercise.

The `Varint` wire type contains a single varint, and is used to encode proto values of type `int32` such as `Person.id`.

The `Len` wire type contains a length expressed as a varint, followed by a payload of that number of bytes. This is used to encode proto values of type `string` such as `Person.name`. It is also used to encode proto values containing sub-messages such as `Person.phones`, where the payload contains an encoding of the sub-message.

## Exercise

The given code also defines callbacks to handle `Person` and `PhoneNumber` fields, and to parse a message into a series of calls to those callbacks.

What remains for you is to implement the `parse_field` function and the `ProtoMessage` trait for `Person` and `PhoneNumber`.

```

1  /// A wire type as seen on the wire.
2  enum WireType {
3      /// The Varint WireType indicates the value is a single VARINT.
4      Varint,
5      // The I64 WireType indicates that the value is precisely 8 bytes in
6      // little-endian order containing a 64-bit signed integer or double type.
7      //I64, -- not needed for this exercise
8      /// The Len WireType indicates that the value is a length represented as
9      /// VARINT followed by exactly that number of bytes.
10     Len,
11     // The I32 WireType indicates that the value is precisely 4 bytes in
12     // little-endian order containing a 32-bit signed integer or float type.
13     //I32, -- not needed for this exercise
14 }
15
16 #[derive(Debug)]
17 /// A field's value, typed based on the wire type.
18 enum FieldValue<'a> {
19     Varint(u64),
20     //I64(i64), -- not needed for this exercise
21     Len(&'a [u8]),
22     //I32(i32), -- not needed for this exercise
23 }
24
25 #[derive(Debug)]
26 /// A field, containing the field number and its value.
27 struct Field<'a> {
28     field_num: u64,
29     value: FieldValue<'a>,
30 }
31
32 trait ProtoMessage<'a>: Default {
33     fn add_field(&mut self, field: Field<'a>);
34 }
35
36 impl From<u64> for WireType {
37     fn from(value: u64) -> Self {
38         match value {
39             0 => WireType::Varint,
40             //1 => WireType::I64, -- not needed for this exercise
41             2 => WireType::Len,
42             //5 => WireType::I32, -- not needed for this exercise
43             _ => panic!("Invalid wire type: {value}"),
44         }
45     }
46 }
47
48 impl<'a> FieldValue<'a> {
49     fn as_str(&self) -> &'a str {
50         let FieldValue::Len(data) = self else {
51             panic!("Expected string to be a `Len` field");
52         };
53         std::str::from_utf8(data).expect("Invalid string")
54     }
55 }

```

```

56     fn as_bytes(&self) -> &'a [u8] {
57         let FieldValue::Len(data) = self else {
58             panic!("Expected bytes to be a `Len` field");
59         };
60         data
61     }
62
63     fn as_u64(&self) -> u64 {
64         let FieldValue::Varint(value) = self else {
65             panic!("Expected `u64` to be a `Varint` field");
66         };
67         *value
68     }
69 }
70
71 /// Parse a VARINT, returning the parsed value and the remaining bytes.
72 fn parse_varint(data: &[u8]) -> (u64, &[u8]) {
73     for i in 0..7 {
74         let Some(b) = data.get(i) else {
75             panic!("Not enough bytes for varint");
76         };
77         if b & 0x80 == 0 {
78             // This is the last byte of the VARINT, so convert it to
79             // a u64 and return it.
80             let mut value = 0u64;
81             for b in data[..=i].iter().rev() {
82                 value = (value << 7) | (b & 0x7f) as u64;
83             }
84             return (value, &data[i + 1..]);
85         }
86     }
87
88     // More than 7 bytes is invalid.
89     panic!("Too many bytes for varint");
90 }
91
92 /// Convert a tag into a field number and a WireType.
93 fn unpack_tag(tag: u64) -> (u64, WireType) {
94     let field_num = tag >> 3;
95     let wire_type = WireType::from(tag & 0x7);
96     (field_num, wire_type)
97 }
98
99
100 /// Parse a field, returning the remaining bytes
101 fn parse_field(data: &[u8]) -> (Field, &[u8]) {
102     let (tag, remainder) = parse_varint(data);
103     let (field_num, wire_type) = unpack_tag(tag);
104     let (fieldvalue, remainder) = match wire_type {
105         _ => todo!("Based on the wire type, build a Field, consuming as many |
106     };
107     todo!("Return the field, and any un-consumed bytes.")
108 }
109

```

```

110 /// Parse a message in the given data, calling `T::add_field` for each field
111 /// the message.
112 ///
113 /// The entire input is consumed.
114 fn parse_message<'a, T: ProtoMessage<'a>>(mut data: &'a [u8]) -> T {
115     let mut result = T::default();
116     while !data.is_empty() {
117         let parsed = parse_field(data);
118         result.add_field(parsed.0);
119         data = parsed.1;
120     }
121     result
122 }
123
124 #[derive(Debug, Default)]
125 struct PhoneNumber<'a> {
126     number: &'a str,
127     type_: &'a str,
128 }
129
130 #[derive(Debug, Default)]
131 struct Person<'a> {
132     name: &'a str,
133     id: u64,
134     phone: Vec<PhoneNumber<'a>>,
135 }
136
137 // TODO: Implement ProtoMessage for Person and PhoneNumber.
138
139 #[test]
140 fn test_id() {
141     let person_id: Person = parse_message(&[0x10, 0x2a]);
142     assert_eq!(person_id, Person { name: "", id: 42, phone: vec![] });
143 }
144
145 #[test]
146 fn test_name() {
147     let person_name: Person = parse_message(&[
148         0x0a, 0x0e, 0x62, 0x65, 0x61, 0x75, 0x74, 0x69, 0x66, 0x75, 0x6c, 0x20,
149         0x6e, 0x61, 0x6d, 0x65,
150     ]);
151     assert_eq!(person_name, Person { name: "beautiful name", id: 0, phone: vec![] });
152 }
153
154 #[test]
155 fn test_just_person() {
156     let person_name_id: Person =
157         parse_message(&[0x0a, 0x04, 0x45, 0x76, 0x61, 0x6e, 0x10, 0x16]);
158     assert_eq!(person_name_id, Person { name: "Evan", id: 22, phone: vec![] });
159 }
160
161 #[test]
162 fn test_phone() {
163     let phone: Person = parse_message(&[
164         0x0a, 0x0a, 0x1a, 0x0a, 0x1a, 0x16, 0x0a, 0x0a, 0x2b, 0x31, 0x32, 0x31,

```

```

164         0x0a, 0x07, 0x6d, 0x61, 0x78, 0x77, 0x65, 0x6c, 0x6c, 0x10, 0x2a, 0x10,
165         0x34, 0x2d, 0x37, 0x37, 0x37, 0x2d, 0x39, 0x30, 0x39, 0x30, 0x12, 0x06,
166         0x68, 0x6f, 0x6d, 0x65,
167     ]);
168     assert_eq!(
169         phone,
170         Person {
171             name: "",
172             id: 0,
173             phone: vec![PhoneNumber { number: "+1234-777-9090", type_: "home"
174         }
175     ]);
176 }
177
178 // Put that all together into a single parse.
179 #[test]
180 fn test_full_person() {
181     let person: Person = parse_message(&[
182         0x0a, 0x07, 0x6d, 0x61, 0x78, 0x77, 0x65, 0x6c, 0x6c, 0x10, 0x2a, 0x10,
183         0x16, 0x0a, 0x0e, 0x2b, 0x31, 0x32, 0x30, 0x32, 0x2d, 0x35, 0x35, 0x30,
184         0x2d, 0x31, 0x32, 0x31, 0x32, 0x12, 0x04, 0x68, 0x6f, 0x6d, 0x65, 0x10,
185         0x18, 0x0a, 0x0e, 0x2b, 0x31, 0x38, 0x30, 0x30, 0x2d, 0x38, 0x36, 0x30,
186         0x2d, 0x35, 0x33, 0x30, 0x38, 0x12, 0x06, 0x6d, 0x6f, 0x62, 0x69, 0x6d,
187         0x65,
188     ]);
189     assert_eq!(
190         person,
191         Person {
192             name: "maxwell",
193             id: 42,
194             phone: vec![
195                 PhoneNumber { number: "+1202-555-1212", type_: "home" },
196                 PhoneNumber { number: "+1800-867-5308", type_: "mobile" },
197             ]
198         }
199     );
200 }

```

### ▼ Speaker Notes

This slide and its sub-slides should take about 30 minutes.

- In this exercise there are various cases where protobuf parsing might fail, e.g. if you try to parse an `i32` when there are fewer than 4 bytes left in the data buffer. In normal Rust code we'd handle this with the `Result` enum, but for simplicity in this exercise we panic if any errors are encountered. On day 4 we'll cover error handling in Rust in more detail.





# Solution

```

1  /// A wire type as seen on the wire.
2  enum WireType {
3      /// The Varint WireType indicates the value is a single VARINT.
4      Varint,
5      /// The I64 WireType indicates that the value is precisely 8 bytes in
6      /// little-endian order containing a 64-bit signed integer or double type.
7      ///I64, -- not needed for this exercise
8      /// The Len WireType indicates that the value is a length represented as
9      /// VARINT followed by exactly that number of bytes.
10     Len,
11     /// The I32 WireType indicates that the value is precisely 4 bytes in
12     /// little-endian order containing a 32-bit signed integer or float type.
13     ///I32, -- not needed for this exercise
14 }
15
16 #[derive(Debug)]
17 /// A field's value, typed based on the wire type.
18 enum FieldValue<'a> {
19     Varint(u64),
20     ///I64(i64), -- not needed for this exercise
21     Len(&'a [u8]),
22     ///I32(i32), -- not needed for this exercise
23 }
24
25 #[derive(Debug)]
26 /// A field, containing the field number and its value.
27 struct Field<'a> {
28     field_num: u64,
29     value: FieldValue<'a>,
30 }
31
32 trait ProtoMessage<'a>: Default {
33     fn add_field(&mut self, field: Field<'a>);
34 }
35
36 impl From<u64> for WireType {
37     fn from(value: u64) -> Self {
38         match value {
39             0 => WireType::Varint,
40             ///1 => WireType::I64, -- not needed for this exercise
41             2 => WireType::Len,
42             ///5 => WireType::I32, -- not needed for this exercise
43             _ => panic!("Invalid wire type: {value}"),
44         }
45     }
46 }
47
48 impl<'a> FieldValue<'a> {
49     fn as_str(&self) -> &'a str {
50         let FieldValue::Len(data) = self else {
51             panic!("Expected string to be a `Len` field");

```

```

52     };
53     std::str::from_utf8(data).expect("Invalid string")
54 }
55
56 fn as_bytes(&self) -> &'a [u8] {
57     let FieldValue::Len(data) = self else {
58         panic!("Expected bytes to be a `Len` field");
59     };
60     data
61 }
62
63 fn as_u64(&self) -> u64 {
64     let FieldValue::Varint(value) = self else {
65         panic!("Expected `u64` to be a `Varint` field");
66     };
67     *value
68 }
69 }
70
71 /// Parse a VARINT, returning the parsed value and the remaining bytes.
72 fn parse_varint(data: &[u8]) -> (u64, &[u8]) {
73     for i in 0..7 {
74         let Some(b) = data.get(i) else {
75             panic!("Not enough bytes for varint");
76         };
77         if b & 0x80 == 0 {
78             // This is the last byte of the VARINT, so convert it to
79             // a u64 and return it.
80             let mut value = 0u64;
81             for b in data[..=i].iter().rev() {
82                 value = (value << 7) | (b & 0x7f) as u64;
83             }
84             return (value, &data[i + 1..]);
85         }
86     }
87
88     // More than 7 bytes is invalid.
89     panic!("Too many bytes for varint");
90 }
91
92 /// Convert a tag into a field number and a WireType.
93 fn unpack_tag(tag: u64) -> (u64, WireType) {
94     let field_num = tag >> 3;
95     let wire_type = WireType::from(tag & 0x7);
96     (field_num, wire_type)
97 }
98
99 /// Parse a field, returning the remaining bytes
100 fn parse_field(data: &[u8]) -> (Field, &[u8]) {
101     let (tag, remainder) = parse_varint(data);
102     let (field_num, wire_type) = unpack_tag(tag);
103     let (fieldvalue, remainder) = match wire_type {
104         WireType::Varint => {
105             let (value, remainder) = parse_varint(remainder);
106             (FieldValue::Varint(value), remainder)

```

```

100         (FieldValue::VarInt(value), remainder)
107     }
108     WireType::Len => {
109         let (len, remainder) = parse_varint(remainder);
110         let len: usize = len.try_into().expect("len not a valid `usize`")
111         if remainder.len() < len {
112             panic!("Unexpected EOF");
113         }
114         let (value, remainder) = remainder.split_at(len);
115         (FieldValue::Len(value), remainder)
116     }
117 };
118 (Field { field_num, value: fieldvalue }, remainder)
119 }
120
121 /// Parse a message in the given data, calling `T::add_field` for each field
122 /// the message.
123 ///
124 /// The entire input is consumed.
125 fn parse_message<'a, T: ProtoMessage<'a>>(mut data: &'a [u8]) -> T {
126     let mut result = T::default();
127     while !data.is_empty() {
128         let parsed = parse_field(data);
129         result.add_field(parsed.0);
130         data = parsed.1;
131     }
132     result
133 }
134
135 #[derive(PartialEq)]
136 #[derive(Debug, Default)]
137 struct PhoneNumber<'a> {
138     number: &'a str,
139     type_: &'a str,
140 }
141
142 #[derive(PartialEq)]
143 #[derive(Debug, Default)]
144 struct Person<'a> {
145     name: &'a str,
146     id: u64,
147     phone: Vec<PhoneNumber<'a>>,
148 }
149
150 impl<'a> ProtoMessage<'a> for Person<'a> {
151     fn add_field(&mut self, field: Field<'a>) {
152         match field.field_num {
153             1 => self.name = field.value.as_str(),
154             2 => self.id = field.value.as_u64(),
155             3 => self.phone.push(parse_message(field.value.as_bytes())),
156             _ => {} // skip everything else
157         }
158     }
159 }
160

```

```

161 impl<'a> ProtoMessage<'a> for PhoneNumber<'a> {
162     fn add_field(&mut self, field: Field<'a>) {
163         match field.field_num {
164             1 => self.number = field.value.as_str(),
165             2 => self.type_ = field.value.as_str(),
166             _ => {} // skip everything else
167         }
168     }
169 }
170
171 #[test]
172 fn test_id() {
173     let person_id: Person = parse_message(&[0x10, 0x2a]);
174     assert_eq!(person_id, Person { name: "", id: 42, phone: vec![] });
175 }
176
177 #[test]
178 fn test_name() {
179     let person_name: Person = parse_message(&[
180         0x0a, 0x0e, 0x62, 0x65, 0x61, 0x75, 0x74, 0x69, 0x66, 0x75, 0x6c, 0x2d,
181         0x6e, 0x61, 0x6d, 0x65,
182     ]);
183     assert_eq!(person_name, Person { name: "beautiful name", id: 0, phone: vec![] });
184 }
185
186 #[test]
187 fn test_just_person() {
188     let person_name_id: Person =
189         parse_message(&[0x0a, 0x04, 0x45, 0x76, 0x61, 0x6e, 0x10, 0x16]);
190     assert_eq!(person_name_id, Person { name: "Evan", id: 22, phone: vec![] });
191 }
192
193 #[test]
194 fn test_phone() {
195     let phone: Person = parse_message(&[
196         0x0a, 0x00, 0x10, 0x00, 0x1a, 0x16, 0x0a, 0x0e, 0x2b, 0x31, 0x32, 0x33,
197         0x34, 0x2d, 0x37, 0x37, 0x37, 0x2d, 0x39, 0x30, 0x39, 0x30, 0x12, 0x00,
198         0x68, 0x6f, 0x6d, 0x65,
199     ]);
200     assert_eq!(
201         phone,
202         Person {
203             name: "",
204             id: 0,
205             phone: vec![PhoneNumber { number: "+1234-777-9090", type_: "home"
206         }
207     ];
208 }
209
210 // Put that all together into a single parse.
211 #[test]
212 fn test_full_person() {
213     let person: Person = parse_message(&[
214         0x0a, 0x07, 0x6d, 0x61, 0x78, 0x77, 0x65, 0x6c, 0x6c, 0x10, 0x2a, 0x10,
215         0x16, 0x0a, 0x0e, 0x2b, 0x31, 0x32, 0x33, 0x34, 0x2d, 0x37, 0x37, 0x37,

```

```
215         0x10, 0x0a, 0x0c, 0x2b, 0x01, 0x02, 0x00, 0x02, 0x2a, 0x00, 0x00, 0x00,
216         0x2d, 0x31, 0x32, 0x31, 0x32, 0x12, 0x04, 0x68, 0x6f, 0x6d, 0x65, 0x10,
217         0x18, 0x0a, 0x0e, 0x2b, 0x31, 0x38, 0x30, 0x30, 0x2d, 0x38, 0x36, 0x30,
218         0x2d, 0x35, 0x33, 0x30, 0x38, 0x12, 0x06, 0x6d, 0x6f, 0x62, 0x69, 0x60,
219         0x65,
220     ]);
221     assert_eq!(
222         person,
223         Person {
224             name: "maxwell",
225             id: 42,
226             phone: vec![
227                 PhoneNumber { number: "+1202-555-1212", type_: "home" },
228                 PhoneNumber { number: "+1800-867-5308", type_: "mobile" },
229             ]
230         }
231     );
232 }
```

# Welcome to Day 4

Today we will cover topics relating to building large-scale software in Rust:

- Iterators: a deep dive on the `Iterator` trait.
- Modules and visibility.
- Testing.
- Error handling: panics, `Result`, and the `try` operator `?`.
- Unsafe Rust: the escape hatch when you can't express yourself in safe Rust.

## Schedule

Including 10 minute breaks, this session should take about 2 hours and 50 minutes. It contains:

Segment	Duration
Welcome	3 minutes
Iterators	55 minutes
Modules	45 minutes
Testing	45 minutes

# Iterators

This segment should take about 55 minutes. It contains:

Slide	Duration
Motivation	3 minutes
Iterator Trait	5 minutes
Iterator Helper Methods	5 minutes
collect	5 minutes
Intolterator	5 minutes
Exercise: Iterator Method Chaining	30 minutes

# Motivating Iterators

If you want to iterate over the contents of an array, you'll need to define:

- Some state to keep track of where you are in the iteration process, e.g. an index.
- A condition to determine when iteration is done.
- Logic for updating the state of iteration each loop.
- Logic for fetching each element using that iteration state.

In a C-style for loop you declare these things directly:

```
1 for (int i = 0; i < array_len; i += 1) {  
2     int elem = array[i];  
3 }  
4
```

In Rust we bundle this state and logic together into an object known as an “iterator”.

## ▼ *Speaker Notes*

This slide should take about 3 minutes.

- This slide provides context for what Rust iterators do under the hood. We use the (hopefully) familiar construct of a C-style `for` loop to show how iteration requires some state and some logic, that way on the next slide we can show how an iterator bundles these together.
- Rust doesn't have a C-style `for` loop, but we can express the same thing with `while` :

```
1 let array = [2, 4, 6, 8];  
2 let mut i = 0;  
3 while i < array.len() {  
4     let elem = array[i];  
5     i += 1;  
6 }
```

## More to Explore

There's another way to express array iteration using `for` in C and C++: You can use a pointer to the front and a pointer to the end of the array and then compare those pointers to determine when the loop should end.



```
1 for (int *ptr = array; ptr < array + len; ptr += 1) {  
2     int elem = *ptr;  
3 }  
4
```

If students ask, you can point out that this is how Rust's slice and array iterators work under the hood (though implemented as a Rust iterator).

# Iterator Trait

The `Iterator` trait defines how an object can be used to produce a sequence of values. For example, if we wanted to create an iterator that can produce the elements of a slice it might look something like this:

```
1 struct SliceIter<'s> {
2     slice: &'s [i32],
3     i: usize,
4 }
5
6 impl<'s> Iterator for SliceIter<'s> {
7     type Item = &'s i32;
8
9     fn next(&mut self) -> Option<Self::Item> {
10        if self.i == self.slice.len() {
11            None
12        } else {
13            let next = &self.slice[self.i];
14            self.i += 1;
15            Some(next)
16        }
17    }
18 }
19
20 fn main() {
21     let slice = &[2, 4, 6, 8];
22     let iter = SliceIter { slice, i: 0 };
23     for elem in iter {
24         dbg!(elem);
25     }
26 }
```

## ▼ Speaker Notes

This slide should take about 5 minutes.

- The `sliceIter` example implements the same logic as the C-style `for` loop demonstrated on the last slide.
- Point out to the students that iterators are lazy: Creating the iterator just initializes the struct but does not otherwise do any work. No work happens until the `next` method is called.
- Iterators don't need to be finite! It's entirely valid to have an iterator that will produce values forever. For example, a half open range like `0..` will keep going until integer overflow occurs.

## More to Explore

- The “real” version of `sliceIter` is the `slice::Iter` type in the standard library, however the real version uses pointers under the hood instead of an index in order to eliminate bounds checks.
- The `sliceIter` example is a good example of a struct that contains a reference and therefore uses lifetime annotations.
- You can also demonstrate adding a generic parameter to `sliceIter` to allow it to work with any kind of slice (not just `&[i32]` ).

# Iterator Helper Methods

In addition to the `next` method that defines how an iterator behaves, the `Iterator` trait provides 70+ helper methods that can be used to build customized iterators.

```
1 fn main() {
2     let result: i32 = (1..=10) // Create a range from 1 to 10
3         .filter(|x| x % 2 == 0) // Keep only even numbers
4         .map(|x| x * x) // Square each number
5         .sum(); // Sum up all the squared numbers
6
7     println!("The sum of squares of even numbers from 1 to 10 is: {}", result);
8 }
```

## ▼ Speaker Notes

This slide should take about 5 minutes.

- The `Iterator` trait implements many common functional programming operations over collections (e.g. `map`, `filter`, `reduce`, etc). This is the trait where you can find all the documentation about them.
- Many of these helper methods take the original iterator and produce a new iterator with different behavior. These are known as “iterator adapter methods”.
- Some methods, like `sum` and `count`, consume the iterator and pull all of the elements out of it.
- These methods are designed to be chained together so that it’s easy to build a custom iterator that does exactly what you need.

## More to Explore

- Rust’s iterators are extremely efficient and highly optimizable. Even complex iterators made by combining many adapter methods will still result in code as efficient as equivalent imperative implementations.

# collect

The `collect` method lets you build a collection from an `Iterator`.

```
1 fn main() {
2     let primes = vec![2, 3, 5, 7];
3     let prime_squares = primes.into_iter().map(|p| p * p).collect::<Vec<_>>();
4     println!("prime_squares: {prime_squares:?}");
5 }
```

## ▼ Speaker Notes

This slide should take about 5 minutes.

- Any iterator can be collected in to a `Vec`, `VecDeque`, or `HashSet`. Iterators that produce key-value pairs (i.e. a two-element tuple) can also be collected into `HashMap` and `BTreeMap`.

Show the students the definition for `collect` in the standard library docs. There are two ways to specify the generic type `B` for this method:

- With the “turbofish”: `some_iterator.collect::<COLLECTION_TYPE>()`, as shown. The `_` shorthand used here lets Rust infer the type of the `vec` elements.
- With type inference: `let prime_squares: Vec<_> = some_iterator.collect()`. Rewrite the example to use this form.

## More to Explore

- If students are curious about how this works, you can bring up the `FromIterator` trait, which defines how each type of collection gets built from an iterator.
- In addition to the basic implementations of `FromIterator` for `Vec`, `HashMap`, etc., there are also more specialized implementations which let you do cool things like convert an `Iterator<Item = Result<V, E>>` into a `Result<Vec<V>, E>`.
- The reason type annotations are often needed with `collect` is because it's generic over its return type. This makes it harder for the compiler to infer the correct type in a lot of cases.

# IntoIterator

The `Iterator` trait tells you how to *iterate* once you have created an iterator. The related trait `IntoIterator` defines how to create an iterator for a type. It is used automatically by the `for` loop.

```

1  struct Grid {
2      x_coords: Vec<u32>,
3      y_coords: Vec<u32>,
4  }
5
6  impl IntoIterator for Grid {
7      type Item = (u32, u32);
8      type IntoIter = GridIter;
9      fn into_iter(self) -> GridIter {
10         GridIter { grid: self, i: 0, j: 0 }
11     }
12 }
13
14 struct GridIter {
15     grid: Grid,
16     i: usize,
17     j: usize,
18 }
19
20 impl Iterator for GridIter {
21     type Item = (u32, u32);
22
23     fn next(&mut self) -> Option<(u32, u32)> {
24         if self.i >= self.grid.x_coords.len() {
25             self.i = 0;
26             self.j += 1;
27             if self.j >= self.grid.y_coords.len() {
28                 return None;
29             }
30         }
31         let res = Some((self.grid.x_coords[self.i], self.grid.y_coords[self.j]));
32         self.i += 1;
33         res
34     }
35 }
36
37 fn main() {
38     let grid = Grid { x_coords: vec![3, 5, 7, 9], y_coords: vec![10, 20, 30, 40] };
39     for (x, y) in grid {
40         println!("point = {x}, {y}");
41     }
42 }

```

### ▼ *Speaker Notes*

This slide should take about 5 minutes.

- `IntoIterator` is the trait that makes for loops work. It is implemented by collection types such as `Vec<T>` and references to them such as `&Vec<T>` and `&[T]`. Ranges also implement it. This is why you can iterate over a vector with `for i in some_vec { .. }` but `some_vec.next()` doesn't exist.

Click through to the docs for `IntoIterator`. Every implementation of `IntoIterator` must declare two types:

- `Item`: the type to iterate over, such as `i8`,
- `IntoIter`: the `Iterator` type returned by the `into_iter` method.

Note that `IntoIter` and `Item` are linked: the iterator must have the same `Item` type, which means that it returns `Option<Item>`

The example iterates over all combinations of x and y coordinates.

Try iterating over the grid twice in `main`. Why does this fail? Note that `IntoIterator::into_iter` takes ownership of `self`.

Fix this issue by implementing `IntoIterator` for `&Grid` and creating a `GridRefIter` that iterates by reference. A version with both `GridIter` and `GridRefIter` is available [in this playground](#).

The same problem can occur for standard library types: `for e in some_vector` will take ownership of `some_vector` and iterate over owned elements from that vector. Use `for e in &some_vector` instead, to iterate over references to elements of `some_vector`.

# Exercise: Iterator Method Chaining

In this exercise, you will need to find and use some of the provided methods in the `Iterator` trait to implement a complex calculation.

Copy the following code to <https://play.rust-lang.org/> and make the tests pass. Use an iterator expression and `collect` the result to construct the return value.

```
1  /// Calculate the differences between elements of `values` offset by `offset`,
2  /// wrapping around from the end of `values` to the beginning.
3  ///
4  /// Element `n` of the result is `values[(n+offset)%len] - values[n]`.
5  fn offset_differences(offset: usize, values: Vec<i32>) -> Vec<i32> {
6      todo!()
7  }
8
9  #[test]
10 fn test_offset_one() {
11     assert_eq!(offset_differences(1, vec![1, 3, 5, 7]), vec![2, 2, 2, -6]);
12     assert_eq!(offset_differences(1, vec![1, 3, 5]), vec![2, 2, -4]);
13     assert_eq!(offset_differences(1, vec![1, 3]), vec![2, -2]);
14 }
15
16 #[test]
17 fn test_larger_offsets() {
18     assert_eq!(offset_differences(2, vec![1, 3, 5, 7]), vec![4, 4, -4, -4]);
19     assert_eq!(offset_differences(3, vec![1, 3, 5, 7]), vec![6, -2, -2, -2]);
20     assert_eq!(offset_differences(4, vec![1, 3, 5, 7]), vec![0, 0, 0, 0]);
21     assert_eq!(offset_differences(5, vec![1, 3, 5, 7]), vec![2, 2, 2, -6]);
22 }
23
24 #[test]
25 fn test_degenerate_cases() {
26     assert_eq!(offset_differences(1, vec![0]), vec![0]);
27     assert_eq!(offset_differences(1, vec![1]), vec![0]);
28     let empty: Vec<i32> = vec![];
29     assert_eq!(offset_differences(1, empty), vec![]);
30 }
```



# Solution

```
1  /// Calculate the differences between elements of `values` offset by `offset`,
2  /// wrapping around from the end of `values` to the beginning.
3  ///
4  /// Element `n` of the result is `values[(n+offset)%len] - values[n]`.
5  fn offset_differences(offset: usize, values: Vec<i32>) -> Vec<i32> {
6      let a = values.iter();
7      let b = values.iter().cycle().skip(offset);
8      a.zip(b).map(|(a, b)| *b - *a).collect()
9  }
10
11 #[test]
12 fn test_offset_one() {
13     assert_eq!(offset_differences(1, vec![1, 3, 5, 7]), vec![2, 2, 2, -6]);
14     assert_eq!(offset_differences(1, vec![1, 3, 5]), vec![2, 2, -4]);
15     assert_eq!(offset_differences(1, vec![1, 3]), vec![2, -2]);
16 }
17
18 #[test]
19 fn test_larger_offsets() {
20     assert_eq!(offset_differences(2, vec![1, 3, 5, 7]), vec![4, 4, -4, -4]);
21     assert_eq!(offset_differences(3, vec![1, 3, 5, 7]), vec![6, -2, -2, -2]);
22     assert_eq!(offset_differences(4, vec![1, 3, 5, 7]), vec![0, 0, 0, 0]);
23     assert_eq!(offset_differences(5, vec![1, 3, 5, 7]), vec![2, 2, 2, -6]);
24 }
25
26 #[test]
27 fn test_degenerate_cases() {
28     assert_eq!(offset_differences(1, vec![0]), vec![0]);
29     assert_eq!(offset_differences(1, vec![1]), vec![0]);
30     let empty: Vec<i32> = vec![];
31     assert_eq!(offset_differences(1, empty), vec![]);
32 }
```

# Modules

This segment should take about 45 minutes. It contains:

Slide	Duration
Modules	3 minutes
Filesystem Hierarchy	5 minutes
Visibility	5 minutes
Encapsulation	5 minutes
use, super, self	10 minutes
Exercise: Modules for a GUI Library	15 minutes

# Modules

We have seen how `impl` blocks let us namespace functions to a type.

Similarly, `mod` lets us namespace types and functions:

```
1 mod foo {
2     pub fn do_something() {
3         println!("In the foo module");
4     }
5 }
6
7 mod bar {
8     pub fn do_something() {
9         println!("In the bar module");
10    }
11 }
12
13 fn main() {
14     foo::do_something();
15     bar::do_something();
16 }
```

## ▼ Speaker Notes

This slide should take about 3 minutes.

- Packages provide functionality and include a `Cargo.toml` file that describes how to build a bundle of 1+ crates.
- Crates are a tree of modules, where a binary crate creates an executable and a library crate compiles to a library.
- Modules define organization, scope, and are the focus of this section.

# Filesystem Hierarchy

Omitting the module content will tell Rust to look for it in another file:

```
1 mod garden;
```

This tells Rust that the `garden` module content is found at `src/garden.rs`. Similarly, a `garden::vegetables` module can be found at `src/garden/vegetables.rs`.

The `crate` root is in:

- `src/lib.rs` (for a library crate)
- `src/main.rs` (for a binary crate)

Modules defined in files can be documented, too, using “inner doc comments”. These document the item that contains them – in this case, a module.

```
1 /// This module implements the garden, including a highly performant germinati
2 /// implementation.
3
4 // Re-export types from this module.
5 pub use garden::Garden;
6 pub use seeds::SeedPacket;
7
8 /// Sow the given seed packets.
9 pub fn sow(seeds: Vec<SeedPacket>) {
10     todo!()
11 }
12
13 /// Harvest the produce in the garden that is ready.
14 pub fn harvest(garden: &mut Garden) {
15     todo!()
16 }
```

## ▼ Speaker Notes

This slide should take about 5 minutes.

- Before Rust 2018, modules needed to be located at `module/mod.rs` instead of `module.rs`, and this is still a working alternative for editions after 2018.
- The main reason to introduce `filename.rs` as alternative to `filename/mod.rs` was because many files named `mod.rs` can be hard to distinguish in IDEs.
- Deeper nesting can use folders, even if the main module is a file:

```
src/  
├─ main.rs  
├─ top_module.rs  
└─ top_module/  
    └─ sub_module.rs
```

- The place rust will look for modules can be changed with a compiler directive:

```
#[path = "some/path.rs"]  
mod some_module;
```

This is useful, for example, if you would like to place tests for a module in a file named `some_module_test.rs`, similar to the convention in Go.

# Visibility

Modules are a privacy boundary:

- Module items are private by default (hides implementation details).
- Parent and sibling items are always visible.
- In other words, if an item is visible in module `foo`, it's visible in all the descendants of `foo`.

```
1  mod outer {
2      fn private() {
3          println!("outer::private");
4      }
5
6      pub fn public() {
7          println!("outer::public");
8      }
9
10     mod inner {
11         fn private() {
12             println!("outer::inner::private");
13         }
14
15         pub fn public() {
16             println!("outer::inner::public");
17             super::private();
18         }
19     }
20 }
21
22 fn main() {
23     outer::public();
24 }
```

## ▼ Speaker Notes

This slide should take about 5 minutes.

- Use the `pub` keyword to make modules public.

Additionally, there are advanced `pub(...)` specifiers to restrict the scope of public visibility.

- See the [Rust Reference](#).
- Configuring `pub(crate)` visibility is a common pattern.
- Less commonly, you can give visibility to a specific path.
- In any case, visibility must be granted to an ancestor module (and all of its descendants).

# Visibility and Encapsulation

Like with items in a module, struct fields are also private by default. Private fields are likewise visible within the rest of the module (including child modules). This allows us to encapsulate implementation details of struct, controlling what data and functionality is visible externally.

```
1 use outer::Foo;
2
3 mod outer {
4     pub struct Foo {
5         pub val: i32,
6         is_big: bool,
7     }
8
9     impl Foo {
10        pub fn new(val: i32) -> Self {
11            Self { val, is_big: val > 100 }
12        }
13    }
14
15    pub mod inner {
16        use super::Foo;
17
18        pub fn print_foo(foo: &Foo) {
19            println!("Is {} big? {}", foo.val, foo.is_big);
20        }
21    }
22 }
23
24 fn main() {
25     let foo = Foo::new(42);
26     println!("foo.val = {}", foo.val);
27     // let foo = Foo { val: 42, is_big: true };
28
29     outer::inner::print_foo(&foo);
30     // println!("Is {} big? {}", foo.val, foo.is_big);
31 }
```

## ▼ Speaker Notes

This slide should take about 5 minutes.

- This slide demonstrates how privacy in structs is module-based. Students coming from object oriented languages may be used to types being the encapsulation boundary, so this demonstrates how Rust behaves differently while showing how we can still achieve encapsulation.

- Note how the `is_big` field is fully controlled by `Foo`, allowing `Foo` to control how it's initialized and enforce any invariants it needs to (e.g. that `is_big` is only `true` if `val > 100`).
- Point out how helper functions can be defined in the same module (including child modules) in order to get access to the type's private fields/methods.
- The first commented out line demonstrates that you cannot initialize a struct with private fields. The second one demonstrates that you also can't directly access private fields.
- Enums do not support privacy: Variants and data within those variants is always public.

## More to Explore

- If students want more information about privacy (or lack thereof) in enums, you can bring up `#[doc_hidden]` and `#[non_exhaustive]` and show how they're used to limit what can be done with an enum.
- Module privacy still applies when there are `impl` blocks in other modules ([example in the playground](#)).



# use, super, self

A module can bring symbols from another module into scope with `use`. You will typically see something like this at the top of each module:

```
1 use std::collections::HashSet;
2 use std::process::abort;
```

## Paths

Paths are resolved as follows:

### 1. As a relative path:

- `foo` or `self::foo` refers to `foo` in the current module,
- `super::foo` refers to `foo` in the parent module.

### 2. As an absolute path:

- `crate::foo` refers to `foo` in the root of the current crate,
- `bar::foo` refers to `foo` in the `bar` crate.

### ▼ *Speaker Notes*

This slide should take about 8 minutes.

- It is common to “re-export” symbols at a shorter path. For example, the top-level `lib.rs` in a crate might have

```
mod storage;

pub use storage::disk::DiskStorage;
pub use storage::network::NetworkStorage;
```

making `DiskStorage` and `NetworkStorage` available to other crates with a convenient, short path.

- For the most part, only items that appear in a module need to be `use` 'd. However, a trait must be in scope to call any methods on that trait, even if a type implementing that trait is already in scope. For example, to use the `read_to_string` method on a type implementing the `Read` trait, you need to `use std::io::Read`.

- The `use` statement can have a wildcard: `use std::io::*`. This is discouraged because it is not clear which items are imported, and those might change over time.

# Exercise: Modules for a GUI Library

In this exercise, you will reorganize a small GUI Library implementation. This library defines a `Widget` trait and a few implementations of that trait, as well as a `main` function.

It is typical to put each type or set of closely-related types into its own module, so each widget type should get its own module.

## Cargo Setup

The Rust playground only supports one file, so you will need to make a Cargo project on your local filesystem:

```
cargo init gui-modules
cd gui-modules
cargo run
```

Edit the resulting `src/main.rs` to add `mod` statements, and add additional files in the `src` directory.

## Source

Here's the single-module implementation of the GUI library:

```
1 pub trait Widget {
2     /// Natural width of `self`.
3     fn width(&self) -> usize;
4
5     /// Draw the widget into a buffer.
6     fn draw_into(&self, buffer: &mut dyn std::fmt::Write);
7
8     /// Draw the widget on standard output.
9     fn draw(&self) {
10         let mut buffer = String::new();
11         self.draw_into(&mut buffer);
12         println!("{buffer}");
13     }
14 }
15
16 pub struct Label {
17     label: String,
18 }
19
20 impl Label {
21     fn new(label: &str) -> Label {
22         Label { label: label.to_owned() }
23     }
24 }
25
26 pub struct Button {
27     label: Label,
28 }
29
30 impl Button {
31     fn new(label: &str) -> Button {
32         Button { label: Label::new(label) }
33     }
34 }
35
36 pub struct Window {
37     title: String,
38     widgets: Vec<Box<dyn Widget>>,
39 }
40
41 impl Window {
42     fn new(title: &str) -> Window {
43         Window { title: title.to_owned(), widgets: Vec::new() }
44     }
45
46     fn add_widget(&mut self, widget: Box<dyn Widget>) {
47         self.widgets.push(widget);
48     }
49
50     fn inner_width(&self) -> usize {
51         std::cmp::max(
52             self.title.chars().count(),
53             self.widgets.iter().map(|w| w.width()).max().unwrap_or(0),
54         )
55     }
56 }
```

```

56 }
57
58 impl Widget for Window {
59     fn width(&self) -> usize {
60         // Add 4 paddings for borders
61         self.inner_width() + 4
62     }
63
64     fn draw_into(&self, buffer: &mut dyn std::fmt::Write) {
65         let mut inner = String::new();
66         for widget in &self.widgets {
67             widget.draw_into(&mut inner);
68         }
69
70         let inner_width = self.inner_width();
71
72         // TODO: Change draw_into to return Result<(), std::fmt::Error>. Then
73         // ?-operator here instead of .unwrap().
74         writeln!(buffer, "+-{:<inner_width$}-+", "").unwrap();
75         writeln!(buffer, "| {:^inner_width$} |", &self.title).unwrap();
76         writeln!(buffer, "+={:=<inner_width$}=+", "").unwrap();
77         for line in inner.lines() {
78             writeln!(buffer, "| {:inner_width$} |", line).unwrap();
79         }
80         writeln!(buffer, "+-{:<inner_width$}-+", "").unwrap();
81     }
82 }
83
84 impl Widget for Button {
85     fn width(&self) -> usize {
86         self.label.width() + 8 // add a bit of padding
87     }
88
89     fn draw_into(&self, buffer: &mut dyn std::fmt::Write) {
90         let width = self.width();
91         let mut label = String::new();
92         self.label.draw_into(&mut label);
93
94         writeln!(buffer, "+{:<width$}+", "").unwrap();
95         for line in label.lines() {
96             writeln!(buffer, "|{:^width$}|", &line).unwrap();
97         }
98         writeln!(buffer, "+{:<width$}+", "").unwrap();
99     }
100 }
101
102 impl Widget for Label {
103     fn width(&self) -> usize {
104         self.label.lines().map(|line| line.chars().count()).max().unwrap_or(0)
105     }
106
107     fn draw_into(&self, buffer: &mut dyn std::fmt::Write) {
108         writeln!(buffer, "{}", &self.label).unwrap();
109     }

```

```
110 }
111
112 fn main() {
113     let mut window = Window::new("Rust GUI Demo 1.23");
114     window.add_widget(Box::new(Label::new("This is a small text GUI demo.)))
115     window.add_widget(Box::new(Button::new("Click me!")));
116     window.draw();
117 }
```

### ▼ *Speaker Notes*

This slide and its sub-slides should take about 15 minutes.

Encourage students to divide the code in a way that feels natural for them, and get accustomed to the required `mod`, `use`, and `pub` declarations. Afterward, discuss what organizations are most idiomatic.

# Solution

```
src
├── main.rs
├── widgets
│   ├── button.rs
│   ├── label.rs
│   └── window.rs
└── widgets.rs
```

```
// ---- src/widgets.rs ----
pub use button::Button;
pub use label::Label;
pub use window::Window;

mod button;
mod label;
mod window;

pub trait Widget {
    /// Natural width of `self`.
    fn width(&self) -> usize;

    /// Draw the widget into a buffer.
    fn draw_into(&self, buffer: &mut dyn std::fmt::Write);

    /// Draw the widget on standard output.
    fn draw(&self) {
        let mut buffer = String::new();
        self.draw_into(&mut buffer);
        println!("{}", buffer);
    }
}
```

```
// ---- src/widgets/label.rs ----
use super::Widget;

pub struct Label {
    label: String,
}

impl Label {
    pub fn new(label: &str) -> Label {
        Label { label: label.to_owned() }
    }
}

impl Widget for Label {
    fn width(&self) -> usize {
        // ANCHOR_END: Label-width
        self.label.lines().map(|line| line.chars().count()).max().unwrap_or(0)
    }

    // ANCHOR: Label-draw_into
    fn draw_into(&self, buffer: &mut dyn std::fmt::Write) {
        // ANCHOR_END: Label-draw_into
        writeln!(buffer, "{}", &self.label).unwrap();
    }
}
```



```
// ---- src/widgets/button.rs ----
use super::{Label, Widget};

pub struct Button {
    label: Label,
}

impl Button {
    pub fn new(label: &str) -> Button {
        Button { label: Label::new(label) }
    }
}

impl Widget for Button {
    fn width(&self) -> usize {
        // ANCHOR_END: Button-width
        self.label.width() + 8 // add a bit of padding
    }

    // ANCHOR: Button-draw_into
    fn draw_into(&self, buffer: &mut dyn std::fmt::Write) {
        // ANCHOR_END: Button-draw_into
        let width = self.width();
        let mut label = String::new();
        self.label.draw_into(&mut label);

        writeln!(buffer, "+{:<width$}+", "").unwrap();
        for line in label.lines() {
            writeln!(buffer, "|{: ^width$}|", &line).unwrap();
        }
        writeln!(buffer, "+{:<width$}+", "").unwrap();
    }
}
```

```

// ---- src/widgets/window.rs ----
use super::Widget;

pub struct Window {
    title: String,
    widgets: Vec<Box<dyn Widget>>,
}

impl Window {
    pub fn new(title: &str) -> Window {
        Window { title: title.to_owned(), widgets: Vec::new() }
    }

    pub fn add_widget(&mut self, widget: Box<dyn Widget>) {
        self.widgets.push(widget);
    }

    fn inner_width(&self) -> usize {
        std::cmp::max(
            self.title.chars().count(),
            self.widgets.iter().map(|w| w.width()).max().unwrap_or(0),
        )
    }
}

impl Widget for Window {
    fn width(&self) -> usize {
        // ANCHOR_END: Window-width
        // Add 4 paddings for borders
        self.inner_width() + 4
    }
}

// ANCHOR: Window-draw_into
fn draw_into(&self, buffer: &mut dyn std::fmt::Write) {
    // ANCHOR_END: Window-draw_into
    let mut inner = String::new();
    for widget in &self.widgets {
        widget.draw_into(&mut inner);
    }

    let inner_width = self.inner_width();

    // TODO: after learning about error handling, you can change
    // draw_into to return Result<>, std::fmt::Error>. Then use
    // the ?-operator here instead of .unwrap().
    writeln!(buffer, "+-{:<inner_width$}-+", "").unwrap();
    writeln!(buffer, "| {:^inner_width$} |", &self.title).unwrap();
    writeln!(buffer, "+={:=<inner_width$}=+", "").unwrap();
    for line in inner.lines() {
        writeln!(buffer, "| {:inner_width$} |", line).unwrap();
    }
    writeln!(buffer, "+-{:<inner_width$}-+", "").unwrap();
}

```

```
    }  
}  
  
// ---- src/main.rs ----  
mod widgets;  
  
use widgets::{Button, Label, Widget, Window};  
  
fn main() {  
    let mut window = Window::new("Rust GUI Demo 1.23");  
    window.add_widget(Box::new(Label::new("This is a small text GUI demo.")));  
    window.add_widget(Box::new(Button::new("Click me!")));  
    window.draw();  
}
```

# Testing

This segment should take about 45 minutes. It contains:

Slide	Duration
Unit Tests	5 minutes
Other Types of Tests	5 minutes
Compiler Lints and Clippy	3 minutes
Exercise: Luhn Algorithm	30 minutes

# Unit Tests

Rust and Cargo come with a simple unit test framework. Tests are marked with `#[test]`. Unit tests are often put in a nested `tests` module, using `#[cfg(test)]` to conditionally compile them only when building tests.

```
1 fn first_word(text: &str) -> &str {
2     match text.find(' ') {
3         Some(idx) => &text[..idx],
4         None => &text,
5     }
6 }
7
8 #[cfg(test)]
9 mod tests {
10     use super::*;
11
12     #[test]
13     fn test_empty() {
14         assert_eq!(first_word(""), "");
15     }
16
17     #[test]
18     fn test_single_word() {
19         assert_eq!(first_word("Hello"), "Hello");
20     }
21
22     #[test]
23     fn test_multiple_words() {
24         assert_eq!(first_word("Hello World"), "Hello");
25     }
26 }
```

- This lets you unit test private helpers.
- The `#[cfg(test)]` attribute is only active when you run `cargo test`.

# Other Types of Tests

## Integration Tests

If you want to test your library as a client, use an integration test.

Create a `.rs` file under `tests/`:

```
// tests/my_library.rs
use my_library::init;

#[test]
fn test_init() {
    assert!(init().is_ok());
}
```

These tests only have access to the public API of your crate.

## Documentation Tests

Rust has built-in support for documentation tests:

```
/// Shortens a string to the given length.
///
/// ```
/// # use playground::shorten_string;
/// assert_eq!(shorten_string("Hello World", 5), "Hello");
/// assert_eq!(shorten_string("Hello World", 20), "Hello World");
/// ```
pub fn shorten_string(s: &str, length: usize) -> &str {
    &s[..std::cmp::min(length, s.len())]
}
```

- Code blocks in `///` comments are automatically seen as Rust code.
- The code will be compiled and executed as part of `cargo test`.
- Adding `#` in the code will hide it from the docs, but will still compile/run it.
- Test the above code on the [Rust Playground](#).

# Compiler Lints and Clippy

The Rust compiler produces fantastic error messages, as well as helpful built-in lints. [Clippy](#) provides even more lints, organized into groups that can be enabled per-project.

```
1 #[deny(clippy::cast_possible_truncation)]
2 fn main() {
3     let mut x = 3;
4     while (x < 70000) {
5         x *= 2;
6     }
7     println!("X probably fits in a u16, right? {}", x as u16);
8 }
```

## ▼ *Speaker Notes*

This slide should take about 3 minutes.

There are compiler lints visible here, but not clippy lints. Run `clippy` on the playground site to show clippy warnings. Clippy has extensive documentation of its lints, and adds new lints (including default-deny lints) all the time.

Note that errors or warnings with `help: ...` can be fixed with `cargo fix` or via your editor.

# Exercise: Luhn Algorithm

The [Luhn algorithm](#) is used to validate credit card numbers. The algorithm takes a string as input and does the following to validate the credit card number:

- Ignore all spaces. Reject numbers with fewer than two digits.
- Moving from **right to left**, double every second digit: for the number `1234`, we double `3` and `1`. For the number `98765`, we double `6` and `8`.
- After doubling a digit, sum the digits if the result is greater than 9. So doubling `7` becomes `14` which becomes `1 + 4 = 5`.
- Sum all the undoubled and doubled digits.
- The credit card number is valid if the sum ends with `0`.

The provided code provides a buggy implementation of the luhn algorithm, along with two basic unit tests that confirm that most of the algorithm is implemented correctly.

Copy the code below to <https://play.rust-lang.org/> and write additional tests to uncover bugs in the provided implementation, fixing any bugs you find.



```
1 pub fn luhn(cc_number: &str) -> bool {
2     let mut sum = 0;
3     let mut double = false;
4
5     for c in cc_number.chars().rev() {
6         if let Some(digit) = c.to_digit(10) {
7             if double {
8                 let double_digit = digit * 2;
9                 sum +=
10                    if double_digit > 9 { double_digit - 9 } else { double_dig
11                } else {
12                    sum += digit;
13                }
14                double = !double;
15            } else {
16                continue;
17            }
18        }
19
20        sum % 10 == 0
21    }
22
23    #[cfg(test)]
24    mod test {
25        use super::*;
26
27        #[test]
28        fn test_valid_cc_number() {
29            assert!(luhn("4263 9826 4026 9299"));
30            assert!(luhn("4539 3195 0343 6467"));
31            assert!(luhn("7992 7398 713"));
32        }
33
34        #[test]
35        fn test_invalid_cc_number() {
36            assert!(!luhn("4223 9826 4026 9299"));
37            assert!(!luhn("4539 3195 0343 6476"));
38            assert!(!luhn("8273 1232 7352 0569"));
39        }
40    }
```



# Solution

```

1 pub fn luhn(cc_number: &str) -> bool {
2     let mut sum = 0;
3     let mut double = false;
4     let mut digits = 0;
5
6     for c in cc_number.chars().rev() {
7         if let Some(digit) = c.to_digit(10) {
8             digits += 1;
9             if double {
10                let double_digit = digit * 2;
11                sum +=
12                    if double_digit > 9 { double_digit - 9 } else { double_dig
13            } else {
14                sum += digit;
15            }
16            double = !double;
17        } else if c.is_whitespace() {
18            // New: accept whitespace.
19            continue;
20        } else {
21            // New: reject all other characters.
22            return false;
23        }
24    }
25
26    // New: check that we have at least two digits
27    digits >= 2 && sum % 10 == 0
28 }
29
30 #[cfg(test)]
31 mod test {
32     use super::*;
33
34     #[test]
35     fn test_valid_cc_number() {
36         assert!(luhn("4263 9826 4026 9299"));
37         assert!(luhn("4539 3195 0343 6467"));
38         assert!(luhn("7992 7398 713"));
39     }
40
41     #[test]
42     fn test_invalid_cc_number() {
43         assert!(!luhn("4223 9826 4026 9299"));
44         assert!(!luhn("4539 3195 0343 6476"));
45         assert!(!luhn("8273 1232 7352 0569"));
46     }
47
48     #[test]
49     fn test_non_digit_cc_number() {
50         assert!(!luhn("foo"));
51         assert!(!luhn("foo 0 0"));

```

```
52     }
53
54     #[test]
55     fn test_empty_cc_number() {
56         assert!(!luhn(""));
57         assert!(!luhn(" "));
58         assert!(!luhn("  "));
59         assert!(!luhn("   "));
60     }
61
62     #[test]
63     fn test_single_digit_cc_number() {
64         assert!(!luhn("0"));
65     }
66
67     #[test]
68     fn test_two_digit_cc_number() {
69         assert!(luhn("0 0 "));
70     }
71 }
```

# Welcome Back

Including 10 minute breaks, this session should take about 2 hours and 20 minutes. It contains:

Segment	Duration
Error Handling	55 minutes
Unsafe Rust	1 hour and 15 minutes

# Error Handling

This segment should take about 55 minutes. It contains:

Slide	Duration
Panics	3 minutes
Result	5 minutes
Try Operator	5 minutes
Try Conversions	5 minutes
Error Trait	5 minutes
thiserror	5 minutes
anyhow	5 minutes
Exercise: Rewriting with Result	20 minutes

# Panics

Rust handles fatal errors with a “panic”.

Rust will trigger a panic if a fatal error happens at runtime:

```
1 fn main() {
2     let v = vec![10, 20, 30];
3     dbg!(v[100]);
4 }
```

- Panics are for unrecoverable and unexpected errors.
  - Panics are symptoms of bugs in the program.
  - Runtime failures like failed bounds checks can panic
  - Assertions (such as `assert!`) panic on failure
  - Purpose-specific panics can use the `panic!` macro.
- A panic will “unwind” the stack, dropping values just as if the functions had returned.
- Use non-panicking APIs (such as `Vec::get`) if crashing is not acceptable.

## ▼ Speaker Notes

This slide should take about 3 minutes.

By default, a panic will cause the stack to unwind. The unwinding can be caught:

```
1 use std::panic;
2
3 fn main() {
4     let result = panic::catch_unwind(|| "No problem here!");
5     dbg!(result);
6
7     let result = panic::catch_unwind(|| {
8         panic!("oh no!");
9     });
10    dbg!(result);
11 }
```

- Catching is unusual; do not attempt to implement exceptions with `catch_unwind!`
- This can be useful in servers which should keep running even if a single request crashes.
- This does not work if `panic = 'abort'` is set in your `Cargo.toml`.

# Result

Our primary mechanism for error handling in Rust is the `Result` enum, which we briefly saw when discussing standard library types.

```
1 use std::fs::File;
2 use std::io::Read;
3
4 fn main() {
5     let file: Result<File, std::io::Error> = File::open("diary.txt");
6     match file {
7         Ok(mut file) => {
8             let mut contents = String::new();
9             if let Ok(bytes) = file.read_to_string(&mut contents) {
10                println!("Dear diary: {contents} ({bytes} bytes)");
11            } else {
12                println!("Could not read file content");
13            }
14        }
15        Err(err) => {
16            println!("The diary could not be opened: {err}");
17        }
18    }
19 }
```

## ▼ Speaker Notes

This slide should take about 5 minutes.

- `Result` has two variants: `Ok` which contains the success value, and `Err` which contains an error value of some kind.
- Whether or not a function can produce an error is encoded in the function's type signature by having the function return a `Result` value.
- Like with `Option`, there is no way to forget to handle an error: You cannot access either the success value or the error value without first pattern matching on the `Result` to check which variant you have. Methods like `unwrap` make it easier to write quick-and-dirty code that doesn't do robust error handling, but means that you can always see in your source code where proper error handling is being skipped.

## More to Explore

It may be helpful to compare error handling in Rust to error handling conventions that students may be familiar with from other programming languages.



# Exceptions

- Many languages use exceptions, e.g. C++, Java, Python.
- In most languages with exceptions, whether or not a function can throw an exception is not visible as part of its type signature. This generally means that you can't tell when calling a function if it may throw an exception or not.
- Exceptions generally unwind the call stack, propagating upward until a `try` block is reached. An error originating deep in the call stack may impact an unrelated function further up.

# Error Numbers

- Some languages have functions return an error number (or some other error value) separately from the successful return value of the function. Examples include C and Go.
- Depending on the language it may be possible to forget to check the error value, in which case you may be accessing an uninitialized or otherwise invalid success value.

# Try Operator

Runtime errors like connection-refused or file-not-found are handled with the `Result` type, but matching this type on every call can be cumbersome. The try-operator `?` is used to return errors to the caller. It lets you turn the common

```
match some_expression {
    Ok(value) => value,
    Err(err) => return Err(err),
}
```

into the much simpler

```
some_expression?
```

We can use this to simplify our error handling code:

```
1 use std::io::Read;
2 use std::{fs, io};
3
4 fn read_username(path: &str) -> Result<String, io::Error> {
5     let username_file_result = fs::File::open(path);
6     let mut username_file = match username_file_result {
7         Ok(file) => file,
8         Err(err) => return Err(err),
9     };
10
11     let mut username = String::new();
12     match username_file.read_to_string(&mut username) {
13         Ok(_) => Ok(username),
14         Err(err) => Err(err),
15     }
16 }
17
18 fn main() {
19     //fs::write("config.dat", "alice").unwrap();
20     let username = read_username("config.dat");
21     println!("username or error: {username:?}");
22 }
```

## ▼ Speaker Notes

This slide should take about 5 minutes.

Simplify the `read_username` function to use `?`.

Key points:

- The `username` variable can be either `Ok(string)` or `Err(error)`.
- Use the `fs::write` call to test out the different scenarios: no file, empty file, file with username.
- Note that `main` can return a `Result<(), E>` as long as it implements `std::process::Termination`. In practice, this means that `E` implements `Debug`. The executable will print the `Err` variant and return a nonzero exit status on error.

# Try Conversions

The effective expansion of `?` is a little more complicated than previously indicated:

`expression?`

works the same as

```
match expression {  
    Ok(value) => value,  
    Err(err)  => return Err(From::from(err)),  
}
```

The `From::from` call here means we attempt to convert the error type to the type returned by the function. This makes it easy to encapsulate errors into higher-level errors.

# Example

```

1 use std::error::Error;
2 use std::io::Read;
3 use std::{fmt, fs, io};
4
5 #[derive(Debug)]
6 enum ReadUsernameError {
7     IoError(io::Error),
8     EmptyUsername(String),
9 }
10
11 impl Error for ReadUsernameError {}
12
13 impl fmt::Display for ReadUsernameError {
14     fn fmt(&self, f: &mut fmt::Formatter) -> fmt::Result {
15         match self {
16             Self::IoError(e) => write!(f, "I/O error: {e}"),
17             Self::EmptyUsername(path) => write!(f, "Found no username in {path}"),
18         }
19     }
20 }
21
22 impl From<io::Error> for ReadUsernameError {
23     fn from(err: io::Error) -> Self {
24         Self::IoError(err)
25     }
26 }
27
28 fn read_username(path: &str) -> Result<String, ReadUsernameError> {
29     let mut username = String::with_capacity(100);
30     fs::File::open(path)?.read_to_string(&mut username)?;
31     if username.is_empty() {
32         return Err(ReadUsernameError::EmptyUsername(String::from(path)));
33     }
34     Ok(username)
35 }
36
37 fn main() {
38     //std::fs::write("config.dat", "").unwrap();
39     let username = read_username("config.dat");
40     println!("username or error: {username:?}");
41 }

```

## ▼ Speaker Notes

This slide should take about 5 minutes.

The `?` operator must return a value compatible with the return type of the function. For `Result`, it means that the error types have to be compatible. A function that returns `Result<T, ErrorOuter>` can only use `?` on a value of type `Result<U, ErrorInner>` if

`ErrorOuter` and `ErrorInner` are the same type or if `ErrorOuter` implements `From<ErrorInner>`.

A common alternative to a `From` implementation is `Result::map_err`, especially when the conversion only happens in one place.

There is no compatibility requirement for `Option`. A function returning `Option<T>` can use the `?` operator on `Option<U>` for arbitrary `T` and `U` types.

A function that returns `Result` cannot use `?` on `Option` and vice versa. However, `Option::ok_or` converts `Option` to `Result` whereas `Result::ok` turns `Result` into `Option`.

# Dynamic Error Types

Sometimes we want to allow any type of error to be returned without writing our own enum covering all the different possibilities. The `std::error::Error` trait makes it easy to create a trait object that can contain any error.

```
1 use std::error::Error;
2 use std::fs;
3 use std::io::Read;
4
5 fn read_count(path: &str) -> Result<i32, Box<dyn Error>> {
6     let mut count_str = String::new();
7     fs::File::open(path)?.read_to_string(&mut count_str)?;
8     let count: i32 = count_str.parse()?;
9     Ok(count)
10 }
11
12 fn main() {
13     fs::write("count.dat", "1i3").unwrap();
14     match read_count("count.dat") {
15         Ok(count) => println!("Count: {count}"),
16         Err(err) => println!("Error: {err}"),
17     }
18 }
```

## ▼ Speaker Notes

This slide should take about 5 minutes.

The `read_count` function can return `std::io::Error` (from file operations) or `std::num::ParseIntError` (from `String::parse`).

Boxing errors saves on code, but gives up the ability to cleanly handle different error cases differently in the program. As such it's generally not a good idea to use `Box<dyn Error>` in the public API of a library, but it can be a good option in a program where you just want to display the error message somewhere.

Make sure to implement the `std::error::Error` trait when defining a custom error type so it can be boxed.

# thiserror

The `thiserror` crate provides macros to help avoid boilerplate when defining error types. It provides derive macros that assist in implementing `From<T>`, `Display`, and the `Error` trait.

```
1 use std::io::Read;
2 use std::{fs, io};
3 use thiserror::Error;
4
5 #[derive(Debug, Error)]
6 enum ReadUsernameError {
7     #[error("I/O error: {0}")]
8     IoError(#[from] io::Error),
9     #[error("Found no username in {0}")]
10    EmptyUsername(String),
11 }
12
13 fn read_username(path: &str) -> Result<String, ReadUsernameError> {
14     let mut username = String::with_capacity(100);
15     fs::File::open(path)?.read_to_string(&mut username)?;
16     if username.is_empty() {
17         return Err(ReadUsernameError::EmptyUsername(String::from(path)));
18     }
19     Ok(username)
20 }
21
22 fn main() {
23     //fs::write("config.dat", "").unwrap();
24     match read_username("config.dat") {
25         Ok(username) => println!("Username: {username}"),
26         Err(err) => println!("Error: {err:?}"),
27     }
28 }
```

## ▼ Speaker Notes

This slide should take about 5 minutes.

- The `Error` derive macro is provided by `thiserror`, and has lots of useful attributes to help define error types in a compact way.
- The message from `#[error]` is used to derive the `Display` trait.
- Note that the `(thiserror::)Error` derive macro, while it has the effect of implementing the `(std::error::)Error` trait, is not the same this; traits and macros do not share a namespace.



# anyhow

The `anyhow` crate provides a rich error type with support for carrying additional contextual information, which can be used to provide a semantic trace of what the program was doing leading up to the error.

This can be combined with the convenience macros from `thiserror` to avoid writing out trait impls explicitly for custom error types.

```

1 use anyhow::{bail, Context, Result};
2 use std::fs;
3 use std::io::Read;
4 use thiserror::Error;
5
6 #[derive(Clone, Debug, Eq, Error, PartialEq)]
7 #[error("Found no username in {0}")]
8 struct EmptyUsernameError(String);
9
10 fn read_username(path: &str) -> Result<String> {
11     let mut username = String::with_capacity(100);
12     fs::File::open(path)
13         .with_context(|| format!("Failed to open {path}"))?
14         .read_to_string(&mut username)
15         .context("Failed to read")?;
16     if username.is_empty() {
17         bail!(EmptyUsernameError(path.to_string()));
18     }
19     Ok(username)
20 }
21
22 fn main() {
23     //fs::write("config.dat", "").unwrap();
24     match read_username("config.dat") {
25         Ok(username) => println!("Username: {username}"),
26         Err(err) => println!("Error: {err:?}"),
27     }
28 }

```

## ▼ Speaker Notes

This slide should take about 5 minutes.

- `anyhow::Error` is essentially a wrapper around `Box<dyn Error>`. As such it's again generally not a good choice for the public API of a library, but is widely used in applications.
- `anyhow::Result<V>` is a type alias for `Result<V, anyhow::Error>`.
- Functionality provided by `anyhow::Error` may be familiar to Go developers, as it provides similar behavior to the Go `error` type and `Result<T, anyhow::Error>` is much

like a Go `(T, error)` (with the convention that only one element of the pair is meaningful).

- `anyhow::Context` is a trait implemented for the standard `Result` and `Option` types. use `anyhow::Context` is necessary to enable `.context()` and `.with_context()` on those types.

## More to Explore

- `anyhow::Error` has support for downcasting, much like `std::any::Any`; the specific error type stored inside can be extracted for examination if desired with [Error::downcast](#).

# Exercise: Rewriting with Result

In this exercise we're revisiting the expression evaluator exercise that we did in day 2. Our initial solution ignores a possible error case: Dividing by zero! Rewrite `eval` to instead use idiomatic error handling to handle this error case and return an error when it occurs. We provide a simple `DivideByZeroError` type to use as the error type for `eval`.

```

1  ///  
2  #[derive(Debug)]  
3  enum Operation {  
4      Add,  
5      Sub,  
6      Mul,  
7      Div,  
8  }  
9  
10 ///  
11 #[derive(Debug)]  
12 enum Expression {  
13     ///  
14     Op { op: Operation, left: Box<Expression>, right: Box<Expression> },  
15  
16     ///  
17     Value(i64),  
18 }  
19  
20 #[derive(PartialEq, Eq, Debug)]  
21 struct DivideByZeroError;  
22  
23 // The original implementation of the expression evaluator. Update this to  
24 // return a `Result` and produce an error when dividing by 0.  
25 fn eval(e: Expression) -> i64 {  
26     match e {  
27         Expression::Op { op, left, right } => {  
28             let left = eval(*left);  
29             let right = eval(*right);  
30             match op {  
31                 Operation::Add => left + right,  
32                 Operation::Sub => left - right,  
33                 Operation::Mul => left * right,  
34                 Operation::Div => if right != 0 {  
35                     left / right  
36                 } else {  
37                     panic!("Cannot divide by zero!");  
38                 },  
39             }  
40         }  
41         Expression::Value(v) => v,  
42     }  
43 }  
44  
45 #[cfg(test)]  
46 mod test {  
47     use super::*;  
48  
49     #[test]  
50     fn test_error() {  
51         assert_eq!(  
52             eval(Expression::Op {  
53                 op: Operation::Div,  
54                 left: Box::new(Expression::Value(99)),  
55                 right: Box::new(Expression::Value(0))  

```

```
55         right: Box::new(Expression::value(0)),
56     }),
57     Err(DivideByZeroError)
58 );
59 }
60
61 #[test]
62 fn test_ok() {
63     let expr = Expression::Op {
64         op: Operation::Sub,
65         left: Box::new(Expression::Value(20)),
66         right: Box::new(Expression::Value(10)),
67     };
68     assert_eq!(eval(expr), Ok(10));
69 }
70 }
```

### ▼ Speaker Notes

This slide and its sub-slides should take about 20 minutes.

- The starting code here isn't exactly the same as the previous exercise's solution: We've added in an explicit panic to show students where the error case is. Point this out if students get confused.



# Solution

```

1  /// An operation to perform on two subexpressions.
2  #[derive(Debug)]
3  enum Operation {
4      Add,
5      Sub,
6      Mul,
7      Div,
8  }
9
10 /// An expression, in tree form.
11 #[derive(Debug)]
12 enum Expression {
13     /// An operation on two subexpressions.
14     Op { op: Operation, left: Box<Expression>, right: Box<Expression> },
15
16     /// A literal value
17     Value(i64),
18 }
19
20 #[derive(PartialEq, Eq, Debug)]
21 struct DivideByZeroError;
22
23 fn eval(e: Expression) -> Result<i64, DivideByZeroError> {
24     match e {
25         Expression::Op { op, left, right } => {
26             let left = eval(*left)?;
27             let right = eval(*right)?;
28             Ok(match op {
29                 Operation::Add => left + right,
30                 Operation::Sub => left - right,
31                 Operation::Mul => left * right,
32                 Operation::Div => {
33                     if right == 0 {
34                         return Err(DivideByZeroError);
35                     } else {
36                         left / right
37                     }
38                 }
39             })
40         }
41         Expression::Value(v) => Ok(v),
42     }
43 }
44
45 #[cfg(test)]
46 mod test {
47     use super::*;
48
49     #[test]
50     fn test_error() {
51         assert_eq!(

```

```
52         eval(Expression::Op {
53             op: Operation::Div,
54             left: Box::new(Expression::Value(99)),
55             right: Box::new(Expression::Value(0)),
56         }),
57         Err(DivideByZeroError)
58     );
59 }
60
61 #[test]
62 fn test_ok() {
63     let expr = Expression::Op {
64         op: Operation::Sub,
65         left: Box::new(Expression::Value(20)),
66         right: Box::new(Expression::Value(10)),
67     };
68     assert_eq!(eval(expr), Ok(10));
69 }
70 }
```



# Unsafe Rust

This segment should take about 1 hour and 15 minutes. It contains:

Slide	Duration
Unsafe	5 minutes
Dereferencing Raw Pointers	10 minutes
Mutable Static Variables	5 minutes
Unions	5 minutes
Unsafe Functions	15 minutes
Unsafe Traits	5 minutes
Exercise: FFI Wrapper	30 minutes

# Unsafe Rust

The Rust language has two parts:

- **Safe Rust:** memory safe, no undefined behavior possible.
- **Unsafe Rust:** can trigger undefined behavior if preconditions are violated.

We saw mostly safe Rust in this course, but it's important to know what Unsafe Rust is.

Unsafe code is usually small and isolated, and its correctness should be carefully documented. It is usually wrapped in a safe abstraction layer.

Unsafe Rust gives you access to five new capabilities:

- Dereference raw pointers.
- Access or modify mutable static variables.
- Access union fields.
- Call `unsafe` functions, including `extern` functions.
- Implement `unsafe` traits.

We will briefly cover unsafe capabilities next. For full details, please see [Chapter 19.1 in the Rust Book](#) and the [Rustonomicon](#).

## ▼ *Speaker Notes*

This slide should take about 5 minutes.

Unsafe Rust does not mean the code is incorrect. It means that developers have turned off some compiler safety features and have to write correct code by themselves. It means the compiler no longer enforces Rust's memory-safety rules.

# Dereferencing Raw Pointers

Creating pointers is safe, but dereferencing them requires `unsafe` :

```

1  fn main() {
2      let mut s = String::from("careful!");
3
4      let r1 = &raw mut s;
5      let r2 = r1 as *const String;
6
7      // SAFETY: r1 and r2 were obtained from references and so are guaranteed to
8      // be non-null and properly aligned, the objects underlying the references
9      // from which they were obtained are live throughout the whole unsafe
10     // block, and they are not accessed either through the references or
11     // concurrently through any other pointers.
12     unsafe {
13         println!("r1 is: {}", *r1);
14         *r1 = String::from("uhoh");
15         println!("r2 is: {}", *r2);
16     }
17
18     // NOT SAFE. DO NOT DO THIS.
19     /*
20     let r3: &String = unsafe { &*r1 };
21     drop(s);
22     println!("r3 is: {}", *r3);
23     */
24 }

```

## ▼ Speaker Notes

This slide should take about 10 minutes.

It is good practice (and required by the Android Rust style guide) to write a comment for each `unsafe` block explaining how the code inside it satisfies the safety requirements of the unsafe operations it is doing.

In the case of pointer dereferences, this means that the pointers must be *valid*, i.e.:

- The pointer must be non-null.
- The pointer must be *dereferenceable* (within the bounds of a single allocated object).
- The object must not have been deallocated.
- There must not be concurrent accesses to the same location.
- If the pointer was obtained by casting a reference, the underlying object must be live and no reference may be used to access the memory.

In most cases the pointer must also be properly aligned.

The “NOT SAFE” section gives an example of a common kind of UB bug: `*r1` has the `'static` lifetime, so `r3` has type `&'static string`, and thus outlives `s`. Creating a reference from a pointer requires *great care*.

# Mutable Static Variables

It is safe to read an immutable static variable:

```
1 static HELLO_WORLD: &str = "Hello, world!";
2
3 fn main() {
4     println!("HELLO_WORLD: {HELLO_WORLD}");
5 }
```

However, since data races can occur, it is unsafe to read and write mutable static variables:

```
1 static mut COUNTER: u32 = 0;
2
3 fn add_to_counter(inc: u32) {
4     // SAFETY: There are no other threads which could be accessing `COUNTER`.
5     unsafe {
6         COUNTER += inc;
7     }
8 }
9
10 fn main() {
11     add_to_counter(42);
12
13     // SAFETY: There are no other threads which could be accessing `COUNTER`.
14     unsafe {
15         println!("COUNTER: {COUNTER}");
16     }
17 }
```

## ▼ Speaker Notes

This slide should take about 5 minutes.

- The program here is safe because it is single-threaded. However, the Rust compiler is conservative and will assume the worst. Try removing the `unsafe` and see how the compiler explains that it is undefined behavior to mutate a static from multiple threads.
- Using a mutable static is generally a bad idea, but there are some cases where it might make sense in low-level `no_std` code, such as implementing a heap allocator or working with some C APIs.

# Unions

Unions are like enums, but you need to track the active field yourself:

```
1  #[repr(C)]
2  union MyUnion {
3      i: u8,
4      b: bool,
5  }
6
7  fn main() {
8      let u = MyUnion { i: 42 };
9      println!("int: {}", unsafe { u.i });
10     println!("bool: {}", unsafe { u.b }); // Undefined behavior!
11 }
```

## ▼ Speaker Notes

This slide should take about 5 minutes.

Unions are very rarely needed in Rust as you can usually use an enum. They are occasionally needed for interacting with C library APIs.

If you just want to reinterpret bytes as a different type, you probably want `std::mem::transmute` or a safe wrapper such as the `zerocopy` crate.

# Unsafe Functions

A function or method can be marked `unsafe` if it has extra preconditions you must uphold to avoid undefined behaviour.

There are two main categories:

- Rust functions declared `unsafe` with `unsafe fn`.
- Foreign functions in `extern "C"` blocks.

## ▼ *Speaker Notes*

This slide and its sub-slides should take about 15 minutes.

We will look at the two kinds of unsafe functions next.

# Unsafe Rust Functions

You can mark your own functions as `unsafe` if they require particular preconditions to avoid undefined behaviour.

```
1  /// Swaps the values pointed to by the given pointers.
2  ///
3  /// # Safety
4  ///
5  /// The pointers must be valid, properly aligned, and not otherwise accessed f
6  /// the duration of the function call.
7  unsafe fn swap(a: *mut u8, b: *mut u8) {
8      let temp = *a;
9      *a = *b;
10     *b = temp;
11 }
12
13 fn main() {
14     let mut a = 42;
15     let mut b = 66;
16
17     // SAFETY: The pointers must be valid, aligned and unique because they cam
18     // from references.
19     unsafe {
20         swap(&mut a, &mut b);
21     }
22
23     println!("a = {}, b = {}", a, b);
24 }
```

## ▼ Speaker Notes

We wouldn't actually use pointers for a `swap` function — it can be done safely with references.

Note that `unsafe` code is allowed within an `unsafe` function without an `unsafe` block. We can prohibit this with `#[deny(unsafe_op_in_unsafe_fn)]`. Try adding it and see what happens. This will [change in the 2024 Rust edition](#).



# Unsafe External Functions

Functions in a foreign language may also be unsafe:

```
1 use std::ffi::c_char;
2
3 unsafe extern "C" {
4     // `abs` doesn't deal with pointers and doesn't have any safety requirements
5     safe fn abs(input: i32) -> i32;
6
7     /// # Safety
8     ///
9     /// `s` must be a pointer to a NUL-terminated C string which is valid and
10    /// not modified for the duration of this function call.
11    unsafe fn strlen(s: *const c_char) -> usize;
12 }
13
14 fn main() {
15     println!("Absolute value of -3 according to C: {}", abs(-3));
16
17     unsafe {
18         // SAFETY: We pass a pointer to a C string literal which is valid for
19         // the duration of the program.
20         println!("String length: {}", strlen(c"String".as_ptr()));
21     }
22 }
```

## ▼ Speaker Notes

- Rust used to consider all extern functions unsafe, but this changed in Rust 1.82 with `unsafe extern` blocks.
- `abs` must be explicitly marked as `safe` because it is an external function (FFI). Calling external functions is usually only a problem when those functions do things with pointers which might violate Rust's memory model, but in general any C function might have undefined behaviour under any arbitrary circumstances.
- The `"c"` in this example is the ABI; [other ABIs are available too](#).
- Note that there is no verification that the Rust function signature matches that of the function definition – that's up to you!

# Calling Unsafe Functions

Failing to uphold the safety requirements breaks memory safety!

```
1  #[derive(Debug)]
2  #[repr(C)]
3  struct KeyPair {
4      pk: [u16; 4], // 8 bytes
5      sk: [u16; 4], // 8 bytes
6  }
7
8  const PK_BYTE_LEN: usize = 8;
9
10 fn log_public_key(pk_ptr: *const u16) {
11     let pk: &[u16] = unsafe { std::slice::from_raw_parts(pk_ptr, PK_BYTE_LEN) };
12     println!("{pk:?}");
13 }
14
15 fn main() {
16     let key_pair = KeyPair { pk: [1, 2, 3, 4], sk: [0, 0, 42, 0] };
17     log_public_key(key_pair.pk.as_ptr());
18 }
```

Always include a safety comment for each `unsafe` block. It must explain why the code is actually safe. This example is missing a safety comment and is unsound.

## ▼ Speaker Notes

Key points:

- The second argument to `slice::from_raw_parts` is the number of *elements*, not bytes! This example demonstrates unexpected behavior by reading past the end of one array and into another.
- This is undefined behavior because we're reading past the end of the array that the pointer was derived from.
- `log_public_key` should be `unsafe`, because `pk_ptr` must meet certain prerequisites to avoid undefined behaviour. A safe function which can cause undefined behaviour is said to be `unsound`. What should its safety documentation say?
- The standard library contains many low-level unsafe functions. Prefer the safe alternatives when possible!
- If you use an unsafe function as an optimization, make sure to add a benchmark to demonstrate the gain.

# Implementing Unsafe Traits

Like with functions, you can mark a trait as `unsafe` if the implementation must guarantee particular conditions to avoid undefined behaviour.

For example, the `zerocopy` crate has an unsafe trait that looks [something like this](#):

```
1 use std::{mem, slice};
2
3 /// ...
4 /// # Safety
5 /// The type must have a defined representation and no padding.
6 pub unsafe trait IntoBytes {
7     fn as_bytes(&self) -> &[u8] {
8         let len = mem::size_of_val(self);
9         let slf: *const Self = self;
10        unsafe { slice::from_raw_parts(slf.cast::<u8>(), len) }
11    }
12 }
13
14 // SAFETY: `u32` has a defined representation and no padding.
15 unsafe impl IntoBytes for u32 {}
```

## ▼ Speaker Notes

This slide should take about 5 minutes.

There should be a `# Safety` section on the Rustdoc for the trait explaining the requirements for the trait to be safely implemented.

The actual safety section for `IntoBytes` is rather longer and more complicated.

The built-in `Send` and `Sync` traits are unsafe.

# Safe FFI Wrapper

Rust has great support for calling functions through a *foreign function interface* (FFI). We will use this to build a safe wrapper for the `libc` functions you would use from C to read the names of files in a directory.

You will want to consult the manual pages:

- [opendir\(3\)](#)
- [readdir\(3\)](#)
- [closedir\(3\)](#)

You will also want to browse the `std::ffi` module. There you find a number of string types which you need for the exercise:

Types	Encoding	Use
<code>str</code> and <code>String</code>	UTF-8	Text processing in Rust
<code>CStr</code> and <code>CString</code>	NUL-terminated	Communicating with C functions
<code>OsStr</code> and <code>OsString</code>	OS-specific	Communicating with the OS

You will convert between all these types:

- `&str` to `CString`: you need to allocate space for a trailing `\0` character,
- `CString` to `*const i8`: you need a pointer to call C functions,
- `*const i8` to `&CStr`: you need something which can find the trailing `\0` character,
- `&CStr` to `&[u8]`: a slice of bytes is the universal interface for “some unknown data”,
- `&[u8]` to `&OsStr`: `&OsStr` is a step towards `OsString`, use `OsStrExt` to create it,
- `&OsStr` to `OsString`: you need to clone the data in `&OsStr` to be able to return it and call `readdir` again.

The [Nomicon](#) also has a very useful chapter about FFI.

Copy the code below to <https://play.rust-lang.org/> and fill in the missing functions and methods:

```

1  // TODO: remove this when you're done with your implementation.
2  #![allow(unused_imports, unused_variables, dead_code)]
3
4  mod ffi {
5      use std::os::raw::{c_char, c_int};
6      #[cfg(not(target_os = "macos"))]
7      use std::os::raw::{c_long, c_uchar, c_ulong, c_ushort};
8
9      // Opaque type. See https://doc.rust-lang.org/nomicon/ffi.html.
10     #[repr(C)]
11     pub struct DIR {
12         _data: [u8; 0],
13         _marker: core::marker::PhantomData<(*mut u8, core::marker::PhantomPinned)>,
14     }
15
16     // Layout according to the Linux man page for readdir(3), where ino_t and
17     // off_t are resolved according to the definitions in
18     // /usr/include/x86_64-linux-gnu/{sys/types.h, bits/typesizes.h}.
19     #[cfg(not(target_os = "macos"))]
20     #[repr(C)]
21     pub struct dirent {
22         pub d_ino: c_ulong,
23         pub d_off: c_long,
24         pub d_reclen: c_ushort,
25         pub d_type: c_uchar,
26         pub d_name: [c_char; 256],
27     }
28
29     // Layout according to the macOS man page for dir(5).
30     #[cfg(all(target_os = "macos"))]
31     #[repr(C)]
32     pub struct dirent {
33         pub d_fileno: u64,
34         pub d_seekoff: u64,
35         pub d_reclen: u16,
36         pub d_namlen: u16,
37         pub d_type: u8,
38         pub d_name: [c_char; 1024],
39     }
40
41     unsafe extern "C" {
42         pub unsafe fn opendir(s: *const c_char) -> *mut DIR;
43
44         #[cfg(not(all(target_os = "macos", target_arch = "x86_64")))]
45         pub unsafe fn readdir(s: *mut DIR) -> *const dirent;
46
47         // See https://github.com/rust-lang/libc/issues/414 and the section on
48         // _DARWIN_FEATURE_64_BIT_INODE in the macOS man page for stat(2).
49         //
50         // "Platforms that existed before these updates were available" refers
51         // to macOS (as opposed to iOS / wearOS / etc.) on Intel and PowerPC.
52         #[cfg(all(target_os = "macos", target_arch = "x86_64"))]
53         #[link_name = "readdir$INODE64"]
54         pub unsafe fn readdir(s: *mut DIR) -> *const dirent;
55     }

```

```
55
56     pub unsafe fn closedir(s: *mut DIR) -> c_int;
57 }
58 }
59
60 use std::ffi::{CStr, CString, OsStr, OsString};
61 use std::os::unix::ffi::OsStrExt;
62
63 #[derive(Debug)]
64 struct DirectoryIterator {
65     path: CString,
66     dir: *mut ffi::DIR,
67 }
68
69 impl DirectoryIterator {
70     fn new(path: &str) -> Result<DirectoryIterator, String> {
71         // Call opendir and return a Ok value if that worked,
72         // otherwise return Err with a message.
73         todo!()
74     }
75 }
76
77 impl Iterator for DirectoryIterator {
78     type Item = OsString;
79     fn next(&mut self) -> Option<OsString> {
80         // Keep calling readdir until we get a NULL pointer back.
81         todo!()
82     }
83 }
84
85 impl Drop for DirectoryIterator {
86     fn drop(&mut self) {
87         // Call closedir as needed.
88         todo!()
89     }
90 }
91
92 fn main() -> Result<(), String> {
93     let iter = DirectoryIterator::new(".")?;
94     println!("files: {:#?}", iter.collect::<Vec<_>>());
95     Ok(())
96 }
```



# Solution

```

1  mod ffi {
2      use std::os::raw::{c_char, c_int};
3      #[cfg(not(target_os = "macos"))]
4      use std::os::raw::{c_long, c_uchar, c_ulong, c_ushort};
5
6      // Opaque type. See https://doc.rust-lang.org/nomicon/ffi.html.
7      #[repr(C)]
8      pub struct DIR {
9          _data: [u8; 0],
10         _marker: core::marker::PhantomData<(*mut u8, core::marker::PhantomPin
11     }
12
13     // Layout according to the Linux man page for readdir(3), where ino_t and
14     // off_t are resolved according to the definitions in
15     // /usr/include/x86_64-linux-gnu/{sys/types.h, bits/typesizes.h}.
16     #[cfg(not(target_os = "macos"))]
17     #[repr(C)]
18     pub struct dirent {
19         pub d_ino: c_ulong,
20         pub d_off: c_long,
21         pub d_reclen: c_ushort,
22         pub d_type: c_uchar,
23         pub d_name: [c_char; 256],
24     }
25
26     // Layout according to the macOS man page for dir(5).
27     #[cfg(all(target_os = "macos"))]
28     #[repr(C)]
29     pub struct dirent {
30         pub d_fileno: u64,
31         pub d_seekoff: u64,
32         pub d_reclen: u16,
33         pub d_namlen: u16,
34         pub d_type: u8,
35         pub d_name: [c_char; 1024],
36     }
37
38     unsafe extern "C" {
39         pub unsafe fn opendir(s: *const c_char) -> *mut DIR;
40
41         #[cfg(not(all(target_os = "macos", target_arch = "x86_64")))]
42         pub unsafe fn readdir(s: *mut DIR) -> *const dirent;
43
44         // See https://github.com/rust-lang/libc/issues/414 and the section o
45         // _DARWIN_FEATURE_64_BIT_INODE in the macOS man page for stat(2).
46         //
47         // "Platforms that existed before these updates were available" refer
48         // to macOS (as opposed to iOS / wearOS / etc.) on Intel and PowerPC.
49         #[cfg(all(target_os = "macos", target_arch = "x86_64"))]
50         #[link_name = "readdir$INODE64"]
51         pub unsafe fn readdir(s: *mut DIR) -> *const dirent;

```



```

52
53     pub unsafe fn closedir(s: *mut DIR) -> c_int;
54 }
55 }
56
57 use std::ffi::{CStr, CString, OsStr, OsString};
58 use std::os::unix::ffi::OsStrExt;
59
60 #[derive(Debug)]
61 struct DirectoryIterator {
62     path: CString,
63     dir: *mut ffi::DIR,
64 }
65
66 impl DirectoryIterator {
67     fn new(path: &str) -> Result<DirectoryIterator, String> {
68         // Call opendir and return a Ok value if that worked,
69         // otherwise return Err with a message.
70         let path =
71             CString::new(path).map_err(|err| format!("Invalid path: {err}"))?
72         // SAFETY: path.as_ptr() cannot be NULL.
73         let dir = unsafe { ffi::opendir(path.as_ptr()) };
74         if dir.is_null() {
75             Err(format!("Could not open {path:?}")
76         } else {
77             Ok(DirectoryIterator { path, dir })
78         }
79     }
80 }
81
82 impl Iterator for DirectoryIterator {
83     type Item = OsString;
84     fn next(&mut self) -> Option<OsString> {
85         // Keep calling readdir until we get a NULL pointer back.
86         // SAFETY: self.dir is never NULL.
87         let dirent = unsafe { ffi::readdir(self.dir) };
88         if dirent.is_null() {
89             // We have reached the end of the directory.
90             return None;
91         }
92         // SAFETY: dirent is not NULL and dirent.d_name is NUL
93         // terminated.
94         let d_name = unsafe { CStr::from_ptr((*dirent).d_name.as_ptr()) };
95         let os_str = OsStr::from_bytes(d_name.to_bytes());
96         Some(os_str.to_owned())
97     }
98 }
99
100 impl Drop for DirectoryIterator {
101     fn drop(&mut self) {
102         // Call closedir as needed.
103         // SAFETY: self.dir is never NULL.
104         if unsafe { ffi::closedir(self.dir) } != 0 {
105             panic!("Could not close {:?}"
106

```

```
106     }
107 }
108 }
109
110 fn main() -> Result<(), String> {
111     let iter = DirectoryIterator::new(".")?;
112     println!("files: {:#?}", iter.collect::<Vec<_>>());
113     Ok(())
114 }
115
116 #[cfg(test)]
117 mod tests {
118     use super::*;
119     use std::error::Error;
120
121     #[test]
122     fn test_nonexisting_directory() {
123         let iter = DirectoryIterator::new("no-such-directory");
124         assert!(iter.is_err());
125     }
126
127     #[test]
128     fn test_empty_directory() -> Result<(), Box<dyn Error>> {
129         let tmp = tempfile::TempDir::new()?;
130         let iter = DirectoryIterator::new(
131             tmp.path().to_str().ok_or("Non UTF-8 character in path")?,
132         );
133         let mut entries = iter.collect::<Vec<_>>();
134         entries.sort();
135         assert_eq!(entries, &[".", ".."]);
136         Ok(())
137     }
138
139     #[test]
140     fn test_nonempty_directory() -> Result<(), Box<dyn Error>> {
141         let tmp = tempfile::TempDir::new()?;
142         std::fs::write(tmp.path().join("foo.txt"), "The Foo Diaries\n")?;
143         std::fs::write(tmp.path().join("bar.png"), "<PNG>\n")?;
144         std::fs::write(tmp.path().join("crab.rs"), "//! Crab\n")?;
145         let iter = DirectoryIterator::new(
146             tmp.path().to_str().ok_or("Non UTF-8 character in path")?,
147         );
148         let mut entries = iter.collect::<Vec<_>>();
149         entries.sort();
150         assert_eq!(entries, &[".", "..", "bar.png", "crab.rs", "foo.txt"]);
151         Ok(())
152     }
153 }
```

# Welcome to Rust in Android

Rust is supported for system software on Android. This means that you can write new services, libraries, drivers or even firmware in Rust (or improve existing code as needed).

## ▼ *Speaker Notes*

The speaker may mention any of the following given the increased use of Rust in Android:

- Service example: [DNS over HTTP](#).
- Libraries: [Rutabaga Virtual Graphics Interface](#).
- Kernel Drivers: [Binder](#).
- Firmware: [pKVM firmware](#).

# Setup

We will be using a Cuttlefish Android Virtual Device to test our code. Make sure you have access to one or create a new one with:

```
source build/envsetup.sh
lunch aosp_cf_x86_64_phone-trunk_staging-userdebug
acloud create
```

Please see the [Android Developer Codelab](#) for details.

The code on the following pages can be found in the [src/android/](#) directory of the course material. Please `git clone` the repository to follow along.

## ▼ *Speaker Notes*

Key points:

- Cuttlefish is a reference Android device designed to work on generic Linux desktops. MacOS support is also planned.
- The Cuttlefish system image maintains high fidelity to real devices, and is the ideal emulator to run many Rust use cases.

# Build Rules

The Android build system (Soong) supports Rust via a number of modules:

Module Type	Description
<code>rust_binary</code>	Produces a Rust binary.
<code>rust_library</code>	Produces a Rust library, and provides both <code>rlib</code> and <code>dylib</code> variants.
<code>rust_ffi</code>	Produces a Rust C library usable by <code>cc</code> modules, and provides both static and shared variants.
<code>rust_proc_macro</code>	Produces a <code>proc-macro</code> Rust library. These are analogous to compiler plugins.
<code>rust_test</code>	Produces a Rust test binary that uses the standard Rust test harness.
<code>rust_fuzz</code>	Produces a Rust fuzz binary leveraging <code>libfuzzer</code> .
<code>rust_protobuf</code>	Generates source and produces a Rust library that provides an interface for a particular protobuf.
<code>rust_bindgen</code>	Generates source and produces a Rust library containing Rust bindings to C libraries.

We will look at `rust_binary` and `rust_library` next.

## ▼ *Speaker Notes*

Additional items speaker may mention:

- Cargo is not optimized for multi-language repos, and also downloads packages from the internet.
- For compliance and performance, Android must have crates in-tree. It must also interop with C/C++/Java code. Soong fills that gap.
- Soong has many similarities to [Bazel](#), which is the open-source variant of Blaze (used in google3).
- Fun fact: Data from Star Trek is a Soong-type Android.

# Rust Binaries

Let us start with a simple application. At the root of an AOSP checkout, create the following files:

*hello\_rust/Android.bp:*

```
rust_binary {  
    name: "hello_rust",  
    crate_name: "hello_rust",  
    srcs: ["src/main.rs"],  
}
```

*hello\_rust/src/main.rs:*

```
//! Rust demo.  
  
/// Prints a greeting to standard output.  
fn main() {  
    println!("Hello from Rust!");  
}
```

You can now build, push, and run the binary:

```
m hello_rust  
adb push "$ANDROID_PRODUCT_OUT/system/bin/hello_rust" /data/local/tmp  
adb shell /data/local/tmp/hello_rust
```

Hello from Rust!

## ▼ *Speaker Notes*

- Go through the build steps and demonstrate them running in your emulator.
- Notice the extensive documentation comments? The Android build rules enforce that all modules have documentation. Try removing it and see what error you get.
- Stress that the Rust build rules look like the other Soong rules. This is on purpose to make it as easy to use Rust as C++ or Java.

# Rust Libraries

You use `rust_library` to create a new Rust library for Android.

Here we declare a dependency on two libraries:

- `libgreeting`, which we define below,
- `libtextwrap`, which is a crate already vendored in [external/rust/android-crates-io/crates/](#).

*hello\_rust/Android.bp:*

```
rust_binary {
    name: "hello_rust_with_dep",
    crate_name: "hello_rust_with_dep",
    srcs: ["src/main.rs"],
    rustlibs: [
        "libgreetings",
        "libtextwrap",
    ],
    prefer_rlib: true, // Need this to avoid dynamic link error.
}

rust_library {
    name: "libgreetings",
    crate_name: "greetings",
    srcs: ["src/lib.rs"],
}
```

*hello\_rust/src/main.rs:*

```
#![ Rust demo.

use greetings::greeting;
use textwrap::fill;

/// Prints a greeting to standard output.
fn main() {
    println!("{}", fill(&greeting("Bob"), 24));
}
```

*hello\_rust/src/lib.rs:*

```
//! Greeting library.  
  
/// Greet `name`.  
pub fn greeting(name: &str) -> String {  
    format!("Hello {name}, it is very nice to meet you!")  
}
```

You build, push, and run the binary like before:

```
m hello_rust_with_dep  
adb push "$ANDROID_PRODUCT_OUT/system/bin/hello_rust_with_dep" /data/local/tmp  
adb shell /data/local/tmp/hello_rust_with_dep
```

```
Hello Bob, it is very  
nice to meet you!
```

### ▼ *Speaker Notes*

- Go through the build steps and demonstrate them running in your emulator.
- A Rust crate named `greetings` must be built by a rule called `libgreetings`. Note how the Rust code uses the crate name, as is normal in Rust.
- Again, the build rules enforce that we add documentation comments to all public items.



# AIDL

The [Android Interface Definition Language \(AIDL\)](#) is supported in Rust:

- Rust code can call existing AIDL servers,
- You can create new AIDL servers in Rust.

## ▼ *Speaker Notes*

- AIDL is what enables Android apps to interact with each other.
- Since Rust is supported as a first-class citizen in this ecosystem, Rust services can be called by any other process on the phone.

# Birthday Service Tutorial

To illustrate how to use Rust with Binder, we're going to walk through the process of creating a Binder interface. We're then going to both implement the described service and write client code that talks to that service.

# AIDL Interfaces

You declare the API of your service using an AIDL interface:

*birthday\_service/aidl/com/example/birthdayservice/IBirthdayService.aidl:*

```
package com.example.birthdayservice;

/** Birthday service interface. */
interface IBirthdayService {
    /** Generate a Happy Birthday message. */
    String wishHappyBirthday(String name, int years);
}
```

*birthday\_service/aidl/Android.bp:*

```
aidl_interface {
    name: "com.example.birthdayservice",
    srcs: ["com/example/birthdayservice/*.aidl"],
    unstable: true,
    backend: {
        rust: { // Rust is not enabled by default
            enabled: true,
        },
    },
}
```

## ▼ Speaker Notes

- Note that the directory structure under the `aidl/` directory needs to match the package name used in the AIDL file, i.e. the package is `com.example.birthdayservice` and the file is at `aidl/com/example/IBirthdayService.aidl`.

# Generated Service API

Binder generates a trait for each interface definition.

*birthday\_service/aidl/com/example/birthdayservice/IBirthdayService.aidl:*

```
/** Birthday service interface. */  
interface IBirthdayService {  
    /** Generate a Happy Birthday message. */  
    String wishHappyBirthday(String name, int years);  
}
```

*out/soong/intermediates/.../com\_example\_birthdayservice.rs:*

```
trait IBirthdayService {  
    fn wishHappyBirthday(&self, name: &str, years: i32) -> binder::Result<String>;  
}
```

Your service will need to implement this trait, and your client will use this trait to talk to the service.

## ▼ *Speaker Notes*

- Point out how the generated function signature, specifically the argument and return types, correspond the interface definition.
  - `String` for an argument results in a different Rust type than `string` as a return type.

# Service Implementation

We can now implement the AIDL service:

*birthday\_service/src/lib.rs:*

```

//! Implementation of the `IBirthdayService` AIDL interface.
use
com_example_birthdayservice::aidl::com::example::birthdayservice::IBirthdayService
::IBirthdayService;
use com_example_birthdayservice::binder;

/// The `IBirthdayService` implementation.
pub struct BirthdayService;

impl binder::Interface for BirthdayService {}

impl IBirthdayService for BirthdayService {
    fn wishHappyBirthday(&self, name: &str, years: i32) -> binder::Result<String>
    {
        Ok(format!("Happy Birthday {name}, congratulations with the {years}
years!"))
    }
}

```

*birthday\_service/Android.bp:*

```

rust_library {
    name: "libbirthdayservice",
    srcs: ["src/lib.rs"],
    crate_name: "birthdayservice",
    rustlibs: [
        "com.example.birthdayservice-rust",
        "libbinder_rs",
    ],
}

```

## ▼ Speaker Notes

- Point out the path to the generated `IBirthdayService` trait, and explain why each of the segments is necessary.
- Note that `wishHappyBirthday` and other AIDL IPC methods take `&self` (instead of `&mut self`).
  - This is necessary because binder responds to incoming requests on a thread pool, allowing for multiple requests to be processed in parallel. This requires that the

service methods only get a shared reference to `self`.

- Any state that needs to be modified by the service will have to be put in something like a `Mutex` to allow for safe mutation.
- The correct approach for managing service state depends heavily on the details of your service.
- TODO: What does the `binder::Interface` trait do? Are there methods to override? Where source?

# AIDL Server

Finally, we can create a server which exposes the service:

*birthday\_service/src/server.rs:*

```

//! Birthday service.
use birthdayservice::BirthdayService;
use
com_example_birthdayservice::aidl::com::example::birthdayservice::IBirthdayService
::BnBirthdayService;
use com_example_birthdayservice::binder;

const SERVICE_IDENTIFIER: &str = "birthdayservice";

/// Entry point for birthday service.
fn main() {
    let birthday_service = BirthdayService;
    let birthday_service_binder = BnBirthdayService::new_binder(
        birthday_service,
        binder::BinderFeatures::default(),
    );
    binder::add_service(SERVICE_IDENTIFIER, birthday_service_binder.as_binder())
        .expect("Failed to register service");
    binder::ProcessState::join_thread_pool();
}

```

*birthday\_service/Android.bp:*

```

rust_binary {
    name: "birthday_server",
    crate_name: "birthday_server",
    srcs: ["src/server.rs"],
    rustlibs: [
        "com.example.birthdayservice-rust",
        "libbinder_rs",
        "libbirthdayservice",
    ],
    prefer_rlib: true, // To avoid dynamic link error.
}

```

## ▼ Speaker Notes

The process for taking a user-defined service implementation (in this case the `BirthdayService` type, which implements the `IBirthdayService`) and starting it as a Binder service has multiple steps, and may appear more complicated than students are used to if

they've used Binder from C++ or another language. Explain to students why each step is necessary.

1. Create an instance of your service type ( `BirthdayService` ).
2. Wrap the service object in corresponding `Bn*` type ( `BnBirthdayService` in this case).  
This type is generated by Binder and provides the common Binder functionality that would be provided by the `BnBinder` base class in C++. We don't have inheritance in Rust, so instead we use composition, putting our `BirthdayService` within the generated `BnBinderService` .
3. Call `add_service` , giving it a service identifier and your service object (the `BnBirthdayService` object in the example).
4. Call `join_thread_pool` to add the current thread to Binder's thread pool and start listening for connections.



# Deploy

We can now build, push, and start the service:

```
m birthday_server
adb push "$ANDROID_PRODUCT_OUT/system/bin/birthday_server" /data/local/tmp
adb root
adb shell /data/local/tmp/birthday_server
```

In another terminal, check that the service runs:

```
adb shell service check birthdayservice
```

```
Service birthdayservice: found
```

You can also call the service with `service call`:

```
adb shell service call birthdayservice 1 s16 Bob i32 24
```

```
Result: Parcel(
  0x00000000: 00000000 00000036 00610048 00700070 '....6...H.a.p.p.'
  0x00000010: 00200079 00690042 00740072 00640068 'y. .B.i.r.t.h.d.'
  0x00000020: 00790061 00420020 0062006f 0020002c 'a.y. .B.o.b.,. .'
  0x00000030: 006f0063 0067006e 00610072 00750074 'c.o.n.g.r.a.t.u.'
  0x00000040: 0061006c 00690074 006e006f 00200073 'l.a.t.i.o.n.s. .'
  0x00000050: 00690077 00680074 00740020 00650068 'w.i.t.h. .t.h.e.'
  0x00000060: 00320020 00200034 00650079 00720061 ' .2.4. .y.e.a.r.'
  0x00000070: 00210073 00000000 's.!..... ')
```

# AIDL Client

Finally, we can create a Rust client for our new service.

*birthday\_service/src/client.rs:*

```
use
com_example_birthdayservice::aidl::com::example::birthdayservice::IBirthdayService
::IBirthdayService;
use com_example_birthdayservice::binder;

const SERVICE_IDENTIFIER: &str = "birthdayservice";

/// Call the birthday service.
fn main() -> Result<(), Box<dyn Error>> {
    let name = std::env::args().nth(1).unwrap_or_else(|| String::from("Bob"));
    let years = std::env::args()
        .nth(2)
        .and_then(|arg| arg.parse::<i32>().ok())
        .unwrap_or(42);

    binder::ProcessState::start_thread_pool();
    let service = binder::get_interface::<dyn IBirthdayService>
(SERVICE_IDENTIFIER)
        .map_err(|_| "Failed to connect to BirthdayService"?);

    // Call the service.
    let msg = service.wishHappyBirthday(&name, years)?;
    println!("{msg}");
}
```

*birthday\_service/Android.bp:*

```
rust_binary {
    name: "birthday_client",
    crate_name: "birthday_client",
    srcs: ["src/client.rs"],
    rustlibs: [
        "com.example.birthdayservice-rust",
        "libbinder_rs",
    ],
    prefer_rlib: true, // To avoid dynamic link error.
}
```

Notice that the client does not depend on `libbirthdayservice`.

Build, push, and run the client on your device:

```
m birthday_client
adb push "$ANDROID_PRODUCT_OUT/system/bin/birthday_client" /data/local/tmp
adb shell /data/local/tmp/birthday_client Charlie 60
```

Happy Birthday Charlie, congratulations with the 60 years!

### ▼ *Speaker Notes*

- `Strong<dyn IBirthdayService>` is the trait object representing the service that the client has connected to.
  - `Strong` is a custom smart pointer type for Binder. It handles both an in-process ref count for the service trait object, and the global Binder ref count that tracks how many processes have a reference to the object.
  - Note that the trait object that the client uses to talk to the service uses the exact same trait that the server implements. For a given Binder interface, there is a single Rust trait generated that both client and server use.
- Use the same service identifier used when registering the service. This should ideally be defined in a common crate that both the client and server can depend on.

# Changing API

Let us extend the API with more functionality: we want to let clients specify a list of lines for the birthday card:

```
package com.example.birthday-service;

/** Birthday service interface. */
interface IBirthdayService {
    /** Generate a Happy Birthday message. */
    String wishHappyBirthday(String name, int years, in String[] text);
}
```

This results in an updated trait definition for `IBirthdayService` :

```
trait IBirthdayService {
    fn wishHappyBirthday(
        &self,
        name: &str,
        years: i32,
        text: &[String],
    ) -> binder::Result<String>;
}
```

## ▼ Speaker Notes

- Note how the `string[]` in the AIDL definition is translated as a `&[String]` in Rust, i.e. that idiomatic Rust types are used in the generated bindings wherever possible:
  - `in` array arguments are translated to slices.
  - `out` and `inout` args are translated to `&mut Vec<T>`.
  - Return values are translated to returning a `Vec<T>`.

# Updating Client and Service

Update the client and server code to account for the new API.

*birthday\_service/src/lib.rs:*

```
impl IBirthdayService for BirthdayService {
    fn wishHappyBirthday(
        &self,
        name: &str,
        years: i32,
        text: &[String],
    ) -> binder::Result<String> {
        let mut msg = format!(
            "Happy Birthday {name}, congratulations with the {years} years!",
        );

        for line in text {
            msg.push('\n');
            msg.push_str(line);
        }

        Ok(msg)
    }
}
```

*birthday\_service/src/client.rs:*

```
let msg = service.wishHappyBirthday(
    &name,
    years,
    &[
        String::from("Habby birfday to yuuuuu"),
        String::from("And also: many more"),
    ],
)?;
```

## ▼ Speaker Notes

- TODO: Move code snippets into project files where they'll actually be built?

# Working With AIDL Types

AIDL types translate into the appropriate idiomatic Rust type:

- Primitive types map (mostly) to idiomatic Rust types.
- Collection types like slices, `Vec`s and string types are supported.
- References to AIDL objects and file handles can be sent between clients and services.
- File handles and parcelables are fully supported.

# Primitive Types

Primitive types map (mostly) idiomatically:

AIDL Type	Rust Type	Note
boolean	bool	
byte	i8	Note that bytes are signed.
char	u16	Note the usage of u16 , NOT u32 .
int	i32	
long	i64	
float	f32	
double	f64	
String	String	

# Array Types

The array types ( `T[]` , `byte[]` , and `List<T>` ) get translated to the appropriate Rust array type depending on how they are used in the function signature:

Position	Rust Type
in argument	<code>&amp;[T]</code>
out / inout argument	<code>&amp;mut Vec&lt;T&gt;</code>
Return	<code>Vec&lt;T&gt;</code>

## ▼ *Speaker Notes*

- In Android 13 or higher, fixed-size arrays are supported, i.e. `T[N]` becomes `[T; N]` . Fixed-size arrays can have multiple dimensions (e.g. `int[3][4]` ). In the Java backend, fixed-size arrays are represented as array types.
- Arrays in parcelable fields always get translated to `Vec<T>` .



# Sending Objects

AIDL objects can be sent either as a concrete AIDL type or as the type-erased `IBinder` interface:

*birthday\_service/aidl/com/example/birthdayservice/IBirthdayInfoProvider.aidl:*

```
package com.example.birthdayservice;

interface IBirthdayInfoProvider {
    String name();
    int years();
}
```

*birthday\_service/aidl/com/example/birthdayservice/IBirthdayService.aidl:*

```
import com.example.birthdayservice.IBirthdayInfoProvider;

interface IBirthdayService {
    /** The same thing, but using a binder object. */
    String wishWithProvider(IBirthdayInfoProvider provider);

    /** The same thing, but using `IBinder`. */
    String wishWithErasedProvider(IBinder provider);
}
```

*birthday\_service/src/client.rs:*

```
/// Rust struct implementing the `IBirthdayInfoProvider` interface.
struct InfoProvider {
    name: String,
    age: u8,
}

impl binder::Interface for InfoProvider {}

impl IBirthdayInfoProvider for InfoProvider {
    fn name(&self) -> binder::Result<String> {
        Ok(self.name.clone())
    }

    fn years(&self) -> binder::Result<i32> {
        Ok(self.age as i32)
    }
}

fn main() {
    binder::ProcessState::start_thread_pool();
    let service = connect().expect("Failed to connect to BirthdayService");

    // Create a binder object for the `IBirthdayInfoProvider` interface.
    let provider = BnBirthdayInfoProvider::new_binder(
        InfoProvider { name: name.clone(), age: years as u8 },
        BinderFeatures::default(),
    );

    // Send the binder object to the service.
    service.wishWithProvider(&provider)?;

    // Perform the same operation but passing the provider as an `SpIBinder`.
    service.wishWithErasedProvider(&provider.as_binder())?;
}
```

### ▼ Speaker Notes

- Note the usage of `BnBirthdayInfoProvider`. This serves the same purpose as `BnBirthdayService` that we saw previously.

# Parcelables

Binder for Rust supports sending parcelables directly:

*birthday\_service/aidl/com/example/birthdayservice/BirthdayInfo.aidl:*

```
package com.example.birthdayservice;

parcelable BirthdayInfo {
    String name;
    int years;
}
```

*birthday\_service/aidl/com/example/birthdayservice/IBirthdayService.aidl:*

```
import com.example.birthdayservice.BirthdayInfo;

interface IBirthdayService {
    /** The same thing, but with a parcelable. */
    String wishWithInfo(in BirthdayInfo info);
}
```

*birthday\_service/src/client.rs:*

```
fn main() {
    binder::ProcessState::start_thread_pool();
    let service = connect().expect("Failed to connect to BirthdayService");

    let info = BirthdayInfo { name: "Alice".into(), years: 123 };
    service.wishWithInfo(&info)?;
}
```

# Sending Files

Files can be sent between Binder clients/servers using the `ParcelFileDescriptor` type:

*birthday\_service/aidl/com/example/birthdayservice/IBirthdayService.aidl:*

```
interface IBirthdayService {
    /** The same thing, but loads info from a file. */
    String wishFromFile(in ParcelFileDescriptor infoFile);
}
```

*birthday\_service/src/client.rs:*

```
fn main() {
    binder::ProcessState::start_thread_pool();
    let service = connect().expect("Failed to connect to BirthdayService");

    // Open a file and put the birthday info in it.
    let mut file = File::create("/data/local/tmp/birthday.info").unwrap();
    writeln!(file, "{name}")?;
    writeln!(file, "{years}")?;

    // Create a `ParcelFileDescriptor` from the file and send it.
    let file = ParcelFileDescriptor::new(file);
    service.wishFromFile(&file)?;
}
```

*birthday\_service/src/lib.rs:*

```

impl IBirthdayService for BirthdayService {
    fn wishFromFile(
        &self,
        info_file: &ParcelFileDescriptor,
    ) -> binder::Result<String> {
        // Convert the file descriptor to a `File`. `ParcelFileDescriptor` wraps
        // an `OwnedFd`, which can be cloned and then used to create a `File`
        // object.
        let mut info_file = info_file
            .as_ref()
            .try_clone()
            .map(File::from)
            .expect("Invalid file handle");

        let mut contents = String::new();
        info_file.read_to_string(&mut contents).unwrap();

        let mut lines = contents.lines();
        let name = lines.next().unwrap();
        let years: i32 = lines.next().unwrap().parse().unwrap();

        Ok(format!("Happy Birthday {name}, congratulations with the {years}
years!"))
    }
}

```

### ▼ Speaker Notes

- `ParcelFileDescriptor` wraps an `OwnedFd`, and so can be created from a `File` (or any other type that wraps an `OwnedFd`), and can be used to create a new `File` handle on the other side.
- Other types of file descriptors can be wrapped and sent, e.g. TCP, UDP, and UNIX sockets.

# Testing in Android

Building on [Testing](#), we will now look at how unit tests work in AOSP. Use the `rust_test` module for your unit tests:

*testing/Android.bp:*

```
rust_library {
    name: "libleftpad",
    crate_name: "leftpad",
    srcs: ["src/lib.rs"],
}

rust_test {
    name: "libleftpad_test",
    crate_name: "leftpad_test",
    srcs: ["src/lib.rs"],
    host_supported: true,
    test_suites: ["general-tests"],
}

rust_test {
    name: "libgoogletest_example",
    crate_name: "googletest_example",
    srcs: ["googletest.rs"],
    rustlibs: ["libgoogletest_rust"],
    host_supported: true,
}

rust_test {
    name: "libmockall_example",
    crate_name: "mockall_example",
    srcs: ["mockall.rs"],
    rustlibs: ["libmockall"],
    host_supported: true,
}
```

*testing/src/lib.rs:*

```

//! Left-padding library.

/// Left-pad `s` to `width`.
pub fn leftpad(s: &str, width: usize) -> String {
    format!("{s:>width$}")
}

#[cfg(test)]
mod tests {
    use super::*;

    #[test]
    fn short_string() {
        assert_eq!(leftpad("foo", 5), "  foo");
    }

    #[test]
    fn long_string() {
        assert_eq!(leftpad("foobar", 6), "foobar");
    }
}

```

You can now run the test with

```
atext --host libleftpad_test
```

The output looks like this:

```

INFO: Elapsed time: 2.666s, Critical Path: 2.40s
INFO: 3 processes: 2 internal, 1 linux-sandbox.
INFO: Build completed successfully, 3 total actions
//comprehensive-rust-android/testing:libleftpad_test_host          PASSED in
2.3s
    PASSED libleftpad_test.tests::long_string (0.0s)
    PASSED libleftpad_test.tests::short_string (0.0s)
Test cases: finished with 2 passing and 0 failing out of 2 test cases

```

Notice how you only mention the root of the library crate. Tests are found recursively in nested modules.

# GoogleTest

The `GoogleTest` crate allows for flexible test assertions using *matchers*:

```
use googletest::prelude::*;

#[googletest::test]
fn test_elements_are() {
    let value = vec!["foo", "bar", "baz"];
    expect_that!(value, elements_are!(eq(&"foo"), lt(&"xyz"), starts_with("b")));
}
```

If we change the last element to `!"`, the test fails with a structured error message pin-pointing the error:

```
---- test_elements_are stdout ----
Value of: value
Expected: has elements:
  0. is equal to "foo"
  1. is less than "xyz"
  2. starts with prefix "!"
Actual: ["foo", "bar", "baz"],
       where element #2 is "baz", which does not start with "!"
       at src/testing/googletest.rs:6:5
Error: See failure output above
```

## ▼ Speaker Notes

This slide should take about 5 minutes.

- `GoogleTest` is not part of the Rust Playground, so you need to run this example in a local environment. Use `cargo add googletest` to quickly add it to an existing Cargo project.
- The `use googletest::prelude::*;` line imports a number of [commonly used macros and types](#).
- This just scratches the surface, there are many builtin matchers. Consider going through the first chapter of [“Advanced testing for Rust applications”](#), a self-guided Rust course: it provides a guided introduction to the library, with exercises to help you get comfortable with `googletest` macros, its matchers and its overall philosophy.
- A particularly nice feature is that mismatches in multi-line strings are shown as a diff:



```
#[test]
fn test_multiline_string_diff() {
    let haiku = "Memory safety found,\n\
                Rust's strong typing guides the way,\n\
                Secure code you'll write.";
    assert_that!(
        haiku,
        eq("Memory safety found,\n\
            Rust's silly humor guides the way,\n\
            Secure code you'll write.")
    );
}
```

shows a color-coded diff (colors not shown here):

```
Value of: haiku
Expected: is equal to "Memory safety found,\nRust's silly humor guides the
way,\nSecure code you'll write."
Actual: "Memory safety found,\nRust's strong typing guides the way,\nSecure code
you'll write.",
  which isn't equal to "Memory safety found,\nRust's silly humor guides the
way,\nSecure code you'll write."
Difference(-actual / +expected):
Memory safety found,
-Rust's strong typing guides the way,
+Rust's silly humor guides the way,
Secure code you'll write.
  at src/testing/googletest.rs:17:5
```

- The crate is a Rust port of [GoogleTest for C++](#).

# Mocking

For mocking, [Mockall](#) is a widely used library. You need to refactor your code to use traits, which you can then quickly mock:

```
use std::time::Duration;

#[mockall::automock]
pub trait Pet {
    fn is_hungry(&self, since_last_meal: Duration) -> bool;
}

#[test]
fn test_robot_dog() {
    let mut mock_dog = MockPet::new();
    mock_dog.expect_is_hungry().return_const(true);
    assert!(mock_dog.is_hungry(Duration::from_secs(10)));
}
```

## ▼ Speaker Notes

This slide should take about 5 minutes.

- Mockall is the recommended mocking library in Android (AOSP). There are other [mocking libraries available on crates.io](#), in particular in the area of mocking HTTP services. The other mocking libraries work in a similar fashion as Mockall, meaning that they make it easy to get a mock implementation of a given trait.
- Note that mocking is somewhat *controversial*: mocks allow you to completely isolate a test from its dependencies. The immediate result is faster and more stable test execution. On the other hand, the mocks can be configured wrongly and return output different from what the real dependencies would do.

If at all possible, it is recommended that you use the real dependencies. As an example, many databases allow you to configure an in-memory backend. This means that you get the correct behavior in your tests, plus they are fast and will automatically clean up after themselves.

Similarly, many web frameworks allow you to start an in-process server which binds to a random port on `localhost`. Always prefer this over mocking away the framework since it helps you test your code in the real environment.

- Mockall is not part of the Rust Playground, so you need to run this example in a local environment. Use `cargo add mockall` to quickly add Mockall to an existing Cargo project.

- Mockall has a lot more functionality. In particular, you can set up expectations which depend on the arguments passed. Here we use this to mock a cat which becomes hungry 3 hours after the last time it was fed:

```
#[test]
fn test_robot_cat() {
    let mut mock_cat = MockPet::new();
    mock_cat
        .expect_is_hungry()
        .with(mockall::predicate::gt(Duration::from_secs(3 * 3600)))
        .return_const(true);
    mock_cat.expect_is_hungry().return_const(false);
    assert!(mock_cat.is_hungry(Duration::from_secs(5 * 3600)));
    assert!(!mock_cat.is_hungry(Duration::from_secs(5)));
}
```

- You can use `.times(n)` to limit the number of times a mock method can be called to `n` — the mock will automatically panic when dropped if this isn't satisfied.

# Logging

You should use the `log` crate to automatically log to `logcat` (on-device) or `stdout` (on-host):

*hello\_rust\_logs/Android.bp:*

```
rust_binary {
    name: "hello_rust_logs",
    crate_name: "hello_rust_logs",
    srcs: ["src/main.rs"],
    rustlibs: [
        "liblog_rust",
        "liblogger",
    ],
    host_supported: true,
}
```

*hello\_rust\_logs/src/main.rs:*

```
//! Rust logging demo.

use log::{debug, error, info};

/// Logs a greeting.
fn main() {
    logger::init(
        logger::Config::default()
            .with_tag_on_device("rust")
            .with_max_level(log::LevelFilter::Trace),
    );
    debug!("Starting program.");
    info!("Things are going fine.");
    error!("Something went wrong!");
}
```

Build, push, and run the binary on your device:

```
m hello_rust_logs
adb push "$ANDROID_PRODUCT_OUT/system/bin/hello_rust_logs" /data/local/tmp
adb shell /data/local/tmp/hello_rust_logs
```

The logs show up in `adb logcat`:

```
adb logcat -s rust
```

```
09-08 08:38:32.454 2420 2420 D rust: hello_rust_logs: Starting program.  
09-08 08:38:32.454 2420 2420 I rust: hello_rust_logs: Things are going fine.  
09-08 08:38:32.454 2420 2420 E rust: hello_rust_logs: Something went wrong!
```

### ▼ *Speaker Notes*

- The logger implementation in `liblogger` is only needed in the final binary, if you're logging from a library you only need the `log` facade crate.

# Interoperability

Rust has excellent support for interoperability with other languages. This means that you can:

- Call Rust functions from other languages.
- Call functions written in other languages from Rust.

When you call functions in a foreign language we say that you're using a *foreign function interface*, also known as FFI.

## ▼ *Speaker Notes*

- This is a key ability of Rust: compiled code becomes indistinguishable from compiled C or C++ code.
- Technically, we say that Rust can be compiled to the same [ABI](#) (application binary interface) as C code.

# Interoperability with C

Rust has full support for linking object files with a C calling convention. Similarly, you can export Rust functions and call them from C.

You can do it by hand if you want:

```
unsafe extern "C" {
    safe fn abs(x: i32) -> i32;
}

fn main() {
    let x = -42;
    let abs_x = abs(x);
    println!("{x}, {abs_x}");
}
```

We already saw this in the [Safe FFI Wrapper exercise](#).

---

This assumes full knowledge of the target platform. Not recommended for production.

---

We will look at better options next.

## ▼ *Speaker Notes*

- The `"c"` part of the `extern` block tells Rust that `abs` can be called using the C ABI (application binary interface).
- The `safe fn abs` part tells that Rust that `abs` is a safe function. By default, extern functions are considered unsafe, but since `abs(x)` is valid for any `x`, we can declare it safe.

# A Simple C Library

Let's first create a small C library:

*interoperability/bindgen/libbirthday.h:*

```
typedef struct card {
    const char* name;
    int years;
} card;

void print_card(const card* card);
```

*interoperability/bindgen/libbirthday.c:*

```
#include <stdio.h>
#include "libbirthday.h"

void print_card(const card* card) {
    printf("+-----\n");
    printf("| Happy Birthday %s!\n", card->name);
    printf("| Congratulations with the %i years!\n", card->years);
    printf("+-----\n");
}
```

Add this to your `Android.bp` file:

*interoperability/bindgen/Android.bp:*

```
cc_library {
    name: "libbirthday",
    srcs: ["libbirthday.c"],
}
```



# Using Bindgen

The `bindgen` tool can auto-generate bindings from a C header file.

Create a wrapper header file for the library (not strictly needed in this example):

*interoperability/bindgen/libbirthday\_wrapper.h:*

```
#include "libbirthday.h"
```

*interoperability/bindgen/Android.bp:*

```
rust_bindgen {  
    name: "libbirthday_bindgen",  
    crate_name: "birthday_bindgen",  
    wrapper_src: "libbirthday_wrapper.h",  
    source_stem: "bindings",  
    static_libs: ["libbirthday"],  
}
```

Finally, we can use the bindings in our Rust program:

*interoperability/bindgen/Android.bp:*

```
rust_binary {  
    name: "print_birthday_card",  
    srcs: ["main.rs"],  
    rustlibs: ["libbirthday_bindgen"],  
    static_libs: ["libbirthday"],  
}
```

*interoperability/bindgen/main.rs:*

```
#!/ Bindgen demo.

use birthday_bindgen::{card, print_card};

fn main() {
    let name = std::ffi::CString::new("Peter").unwrap();
    let card = card { name: name.as_ptr(), years: 42 };
    // SAFETY: The pointer we pass is valid because it came from a Rust
    // reference, and the `name` it contains refers to `name` above which also
    // remains valid. `print_card` doesn't store either pointer to use later
    // after it returns.
    unsafe {
        print_card(&card as *const card);
    }
}
```

### ▼ *Speaker Notes*

- The Android build rules will automatically call `bindgen` for you behind the scenes.
- Notice that the Rust code in `main` is still hard to write. It is good practice to encapsulate the output of `bindgen` in a Rust library which exposes a safe interface to caller.

# Running Our Binary

Build, push, and run the binary on your device:

```
m print_birthday_card
adb push "$ANDROID_PRODUCT_OUT/system/bin/print_birthday_card" /data/local/tmp
adb shell /data/local/tmp/print_birthday_card
```

Finally, we can run auto-generated tests to ensure the bindings work:

*interoperability/bindgen/Android.bp:*

```
rust_test {
    name: "libbirthday_bindgen_test",
    srcs: [":libbirthday_bindgen"],
    crate_name: "libbirthday_bindgen_test",
    test_suites: ["general-tests"],
    auto_gen_config: true,
    clippy_lints: "none", // Generated file, skip linting
    lints: "none",
}
```

```
atest libbirthday_bindgen_test
```

# A Simple Rust Library

Exporting Rust functions and types to C is easy. Here's a simple Rust library:

*interoperability/rust/libanalyze/analyze.rs*

```
1 ///! Rust FFI demo.
2 #[deny(improper_ctypes_definitions)]
3
4 use std::os::raw::c_int;
5
6 /// Analyze the numbers.
7 // SAFETY: There is no other global function of this name.
8 #[unsafe(no_mangle)]
9 pub extern "C" fn analyze_numbers(x: c_int, y: c_int) {
10     if x < y {
11         println!("x ({x}) is smallest!");
12     } else {
13         println!("y ({y}) is probably larger than x ({x})");
14     }
15 }
```

*interoperability/rust/libanalyze/Android.bp*

```
rust_ffi {
    name: "libanalyze_ffi",
    crate_name: "analyze_ffi",
    srcs: ["analyze.rs"],
    include_dirs: ["."],
}
```

## ▼ Speaker Notes

`#[unsafe(no_mangle)]` disables Rust's usual name mangling, so the exported symbol will just be the name of the function. You can also use `#[unsafe(export_name = "some_name")]` to specify whatever name you want.

# Calling Rust

We can now call this from a C binary:

*interoperability/rust/libanalyze/analyze.h*

```
#ifndef ANALYZE_H
#define ANALYZE_H

void analyze_numbers(int x, int y);

#endif
```

*interoperability/rust/analyze/main.c*

```
#include "analyze.h"

int main() {
    analyze_numbers(10, 20);
    analyze_numbers(123, 123);
    return 0;
}
```

*interoperability/rust/analyze/Android.bp*

```
cc_binary {
    name: "analyze_numbers",
    srcs: ["main.c"],
    static_libs: ["libanalyze_ffi"],
}
```

Build, push, and run the binary on your device:

```
m analyze_numbers
adb push "$ANDROID_PRODUCT_OUT/system/bin/analyze_numbers" /data/local/tmp
adb shell /data/local/tmp/analyze_numbers
```

# With C++

The [CXX crate](#) makes it possible to do safe interoperability between Rust and C++.

The overall approach looks like this:

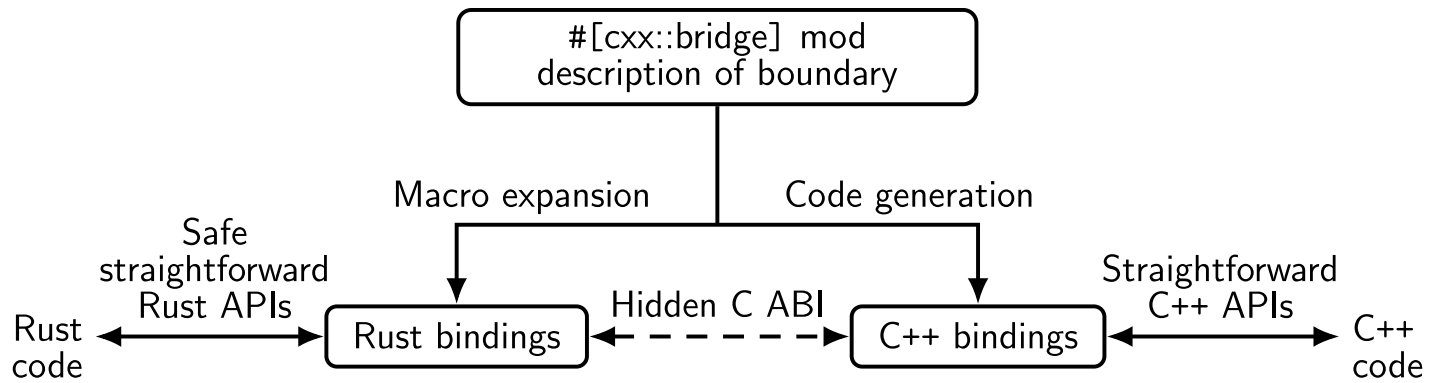

# The Bridge Module

CXX relies on a description of the function signatures that will be exposed from each language to the other. You provide this description using extern blocks in a Rust module annotated with the `#[cxx::bridge]` attribute macro.

```
#[allow(unsafe_op_in_unsafe_fn)]
#[cxx::bridge(namespace = "org::blobstore")]
mod ffi {
    // Shared structs with fields visible to both languages.
    struct BlobMetadata {
        size: usize,
        tags: Vec<String>,
    }

    // Rust types and signatures exposed to C++.
    extern "Rust" {
        type MultiBuf;

        fn next_chunk(buf: &mut MultiBuf) -> &[u8];
    }

    // C++ types and signatures exposed to Rust.
    unsafe extern "C++" {
        include!("include/blobstore.h");

        type BlobstoreClient;

        fn new_blobstore_client() -> UniquePtr<BlobstoreClient>;
        fn put(self: Pin<&mut BlobstoreClient>, parts: &mut MultiBuf) -> u64;
        fn tag(self: Pin<&mut BlobstoreClient>, blobid: u64, tag: &str);
        fn metadata(&self, blobid: u64) -> BlobMetadata;
    }
}
```

## ▼ Speaker Notes

- The bridge is generally declared in an `ffi` module within your crate.
- From the declarations made in the bridge module, CXX will generate matching Rust and C++ type/function definitions in order to expose those items to both languages.
- To view the generated Rust code, use [cargo-expand](#) to view the expanded proc macro. For most of the examples you would use `cargo expand ::ffi` to expand just the `ffi` module (though this doesn't apply for Android projects).
- To view the generated C++ code, look in `target/cxxbridge`.

# Rust Bridge Declarations

```
#[cxx::bridge]
mod ffi {
    extern "Rust" {
        type MyType; // Opaque type
        fn foo(&self); // Method on `MyType`
        fn bar() -> Box<MyType>; // Free function
    }
}

struct MyType(i32);

impl MyType {
    fn foo(&self) {
        println!("{}", self.0);
    }
}

fn bar() -> Box<MyType> {
    Box::new(MyType(123))
}
```

## ▼ *Speaker Notes*

- Items declared in the `extern "Rust"` reference items that are in scope in the parent module.
- The CXX code generator uses your `extern "Rust"` section(s) to produce a C++ header file containing the corresponding C++ declarations. The generated header has the same path as the Rust source file containing the bridge, except with a `.rs.h` file extension.



# Generated C++

```
#[cxx::bridge]
mod ffi {
    // Rust types and signatures exposed to C++.
    extern "Rust" {
        type MultiBuf;

        fn next_chunk(buf: &mut MultiBuf) -> &[u8];
    }
}
```

Results in (roughly) the following C++:

```
struct MultiBuf final : public ::rust::Opaque {
    ~MultiBuf() = delete;

private:
    friend ::rust::layout;
    struct layout {
        static ::std::size_t size() noexcept;
        static ::std::size_t align() noexcept;
    };
};

::rust::Slice<::std::uint8_t const> next_chunk(::org::blobstore::MultiBuf &buf)
noexcept;
```

# C++ Bridge Declarations

```
#[cxx::bridge]
mod ffi {
    // C++ types and signatures exposed to Rust.
    unsafe extern "C++" {
        include!("include/blobstore.h");

        type BlobstoreClient;

        fn new_blobstore_client() -> UniquePtr<BlobstoreClient>;
        fn put(self: Pin<&mut BlobstoreClient>, parts: &mut MultiBuf) -> u64;
        fn tag(self: Pin<&mut BlobstoreClient>, blobid: u64, tag: &str);
        fn metadata(&self, blobid: u64) -> BlobMetadata;
    }
}
```

Results in (roughly) the following Rust:

```
#[repr(C)]
pub struct BlobstoreClient {
    _private: ::cxx::private::Opaque,
}

pub fn new_blobstore_client() -> ::cxx::UniquePtr<BlobstoreClient> {
    extern "C" {
        #[link_name = "org$blobstore$cxxbridge1$new_blobstore_client"]
        fn __new_blobstore_client() -> *mut BlobstoreClient;
    }
    unsafe { ::cxx::UniquePtr::from_raw(__new_blobstore_client()) }
}

impl BlobstoreClient {
    pub fn put(&self, parts: &mut MultiBuf) -> u64 {
        extern "C" {
            #[link_name = "org$blobstore$cxxbridge1$BlobstoreClient$put"]
            fn __put(
                _: &BlobstoreClient,
                parts: *mut ::cxx::core::ffi::c_void,
            ) -> u64;
        }
        unsafe {
            __put(self, parts as *mut MultiBuf as *mut ::cxx::core::ffi::c_void)
        }
    }
}

// ...
```

### ▼ *Speaker Notes*

- The programmer does not need to promise that the signatures they have typed in are accurate. CXX performs static assertions that the signatures exactly correspond with what is declared in C++.
- `unsafe extern` blocks allow you to declare C++ functions that are safe to call from Rust.

# Shared Types

```
#[cxx::bridge]
mod ffi {
    #[derive(Clone, Debug, Hash)]
    struct PlayingCard {
        suit: Suit,
        value: u8, // A=1, J=11, Q=12, K=13
    }

    enum Suit {
        Clubs,
        Diamonds,
        Hearts,
        Spades,
    }
}
```

## ▼ *Speaker Notes*

- Only C-like (unit) enums are supported.
- A limited number of traits are supported for `#[derive()]` on shared types. Corresponding functionality is also generated for the C++ code, e.g. if you derive `Hash` also generates an implementation of `std::hash` for the corresponding C++ type.

# Shared Enums

```
#[cxx::bridge]
mod ffi {
    enum Suit {
        Clubs,
        Diamonds,
        Hearts,
        Spades,
    }
}
```

Generated Rust:

```
#[derive(Copy, Clone, PartialEq, Eq)]
#[repr(transparent)]
pub struct Suit {
    pub repr: u8,
}

#[allow(non_upper_case_globals)]
impl Suit {
    pub const Clubs: Self = Suit { repr: 0 };
    pub const Diamonds: Self = Suit { repr: 1 };
    pub const Hearts: Self = Suit { repr: 2 };
    pub const Spades: Self = Suit { repr: 3 };
}
```

Generated C++:

```
enum class Suit : uint8_t {
    Clubs = 0,
    Diamonds = 1,
    Hearts = 2,
    Spades = 3,
};
```

## ▼ *Speaker Notes*

- On the Rust side, the code generated for shared enums is actually a struct wrapping a numeric value. This is because it is not UB in C++ for an enum class to hold a value different from all of the listed variants, and our Rust representation needs to have the same behavior.

# Rust Error Handling

```
#[cxx::bridge]
mod ffi {
    extern "Rust" {
        fn fallible(depth: usize) -> Result<String>;
    }
}

fn fallible(depth: usize) -> anyhow::Result<String> {
    if depth == 0 {
        return Err(anyhow::Error::msg("fallible1 requires depth > 0"));
    }

    Ok("Success!".into())
}
```

## ▼ Speaker Notes

- Rust functions that return `Result` are translated to exceptions on the C++ side.
- The exception thrown will always be of type `rust::Error`, which primarily exposes a way to get the error message string. The error message will come from the error type's `Display` impl.
- A panic unwinding from Rust to C++ will always cause the process to immediately terminate.

# C++ Error Handling

```
#[cxx::bridge]
mod ffi {
    unsafe extern "C++" {
        include!("example/include/example.h");
        fn fallible(depth: usize) -> Result<String>;
    }
}

fn main() {
    if let Err(err) = ffi::fallible(99) {
        eprintln!("Error: {}", err);
        process::exit(1);
    }
}
```

## ▼ Speaker Notes

- C++ functions declared to return a `Result` will catch any thrown exception on the C++ side and return it as an `Err` value to the calling Rust function.
- If an exception is thrown from an extern "C++" function that is not declared by the CXX bridge to return `Result`, the program calls C++'s `std::terminate`. The behavior is equivalent to the same exception being thrown through a `noexcept` C++ function.

# Additional Types

Rust Type	C++ Type
<code>String</code>	<code>rust::String</code>
<code>&amp;str</code>	<code>rust::Str</code>
<code>CxxString</code>	<code>std::string</code>
<code>&amp;[T] / &amp;mut [T]</code>	<code>rust::Slice</code>
<code>Box&lt;T&gt;</code>	<code>rust::Box&lt;T&gt;</code>
<code>UniquePtr&lt;T&gt;</code>	<code>std::unique_ptr&lt;T&gt;</code>
<code>Vec&lt;T&gt;</code>	<code>rust::Vec&lt;T&gt;</code>
<code>CxxVector&lt;T&gt;</code>	<code>std::vector&lt;T&gt;</code>

## ▼ *Speaker Notes*

- These types can be used in the fields of shared structs and the arguments and returns of extern functions.
- Note that Rust's `string` does not map directly to `std::string`. There are a few reasons for this:
  - `std::string` does not uphold the UTF-8 invariant that `String` requires.
  - The two types have different layouts in memory and so can't be passed directly between languages.
  - `std::string` requires move constructors that don't match Rust's move semantics, so a `std::string` can't be passed by value to Rust.



# Building in Android

Create two genrules: One to generate the CXX header, and one to generate the CXX source file. These are then used as inputs to the `cc_library_static`.

```
// Generate a C++ header containing the C++ bindings
// to the Rust exported functions in lib.rs.
genrule {
    name: "libcxx_test_bridge_header",
    tools: ["cxxbridge"],
    cmd: "$(location cxxbridge) $(in) --header > $(out)",
    srcs: ["lib.rs"],
    out: ["lib.rs.h"],
}

// Generate the C++ code that Rust calls into.
genrule {
    name: "libcxx_test_bridge_code",
    tools: ["cxxbridge"],
    cmd: "$(location cxxbridge) $(in) > $(out)",
    srcs: ["lib.rs"],
    out: ["lib.rs.cc"],
}
```

## ▼ Speaker Notes

- The `cxxbridge` tool is a standalone tool that generates the C++ side of the bridge module. It is included in Android and available as a Soong tool.
- By convention, if your Rust source file is `lib.rs` your header file will be named `lib.rs.h` and your source file will be named `lib.rs.cc`. This naming convention isn't enforced, though.

# Building in Android

Create a `cc_library_static` to build the C++ library, including the CXX generated header and source file.

```
cc_library_static {  
    name: "libcxx_test_cpp",  
    srcs: ["cxx_test.cpp"],  
    generated_headers: [  
        "cxx-bridge-header",  
        "libcxx_test_bridge_header"  
    ],  
    generated_sources: ["libcxx_test_bridge_code"],  
}
```

## ▼ *Speaker Notes*

- Point out that `libcxx_test_bridge_header` and `libcxx_test_bridge_code` are the dependencies for the CXX-generated C++ bindings. We'll show how these are setup on the next slide.
- Note that you also need to depend on the `cxx-bridge-header` library in order to pull in common CXX definitions.
- Full docs for using CXX in Android can be found in [the Android docs](#). You may want to share that link with the class so that students know where they can find these instructions again in the future.

# Building in Android

Create a `rust_binary` that depends on `libcxx` and your `cc_library_static`.

```
rust_binary {  
    name: "cxx_test",  
    srcs: ["lib.rs"],  
    rustlibs: ["libcxx"],  
    static_libs: ["libcxx_test_cpp"],  
}
```

# Interoperability with Java

Java can load shared objects via [Java Native Interface \(JNI\)](#). The [jni crate](#) allows you to create a compatible library.

First, we create a Rust function to export to Java:

*interoperability/java/src/lib.rs:*

```
#![ Rust <-> Java FFI demo.

use jni::objects::{JClass, JString};
use jni::sys::jstring;
use jni::JNIEnv;

/// HelloWorld::hello method implementation.
// SAFETY: There is no other global function of this name.
#[unsafe(no_mangle)]
pub extern "system" fn Java_HelloWorld_hello(
    mut env: JNIEnv,
    _class: JClass,
    name: JString,
) -> jstring {
    let input: String = env.get_string(&name).unwrap().into();
    let greeting = format!("Hello, {input}!");
    let output = env.new_string(greeting).unwrap();
    output.into_raw()
}
```

*interoperability/java/Android.bp:*

```
rust_ffi_shared {
    name: "libhello_jni",
    crate_name: "hello_jni",
    srcs: ["src/lib.rs"],
    rustlibs: ["libjni"],
}
```

We then call this function from Java:

*interoperability/java/HelloWorld.java:*

```
class HelloWorld {
    private static native String hello(String name);

    static {
        System.loadLibrary("hello_jni");
    }

    public static void main(String[] args) {
        String output = HelloWorld.hello("Alice");
        System.out.println(output);
    }
}
```

*interoperability/java/Android.bp:*

```
java_binary {
    name: "helloworld_jni",
    srcs: ["HelloWorld.java"],
    main_class: "HelloWorld",
    jni_libs: ["libhello_jni"],
}
```

Finally, you can build, sync, and run the binary:

```
m helloworld_jni
adb sync # requires adb root && adb remount
adb shell /system/bin/helloworld_jni
```

#### ▼ *Speaker Notes*

- The `unsafe(no_mangle)` attribute instructs Rust to emit the `Java_HelloWorld_hello` symbol exactly as written. This is important so that Java can recognize the symbol as a `hello` method on the `HelloWorld` class.
  - By default, Rust will mangle (rename) symbols so that a binary can link in two versions of the same Rust crate.

# Welcome to Rust in Chromium

Rust is supported for third-party libraries in Chromium, with first-party glue code to connect between Rust and existing Chromium C++ code.

---

Today, we'll call into Rust to do something silly with strings. If you've got a corner of the code where you're displaying a UTF8 string to the user, feel free to follow this recipe in your part of the codebase instead of the exact part we talk about.

---

# Setup

Make sure you can build and run Chromium. Any platform and set of build flags is OK, so long as your code is relatively recent (commit position 1223636 onwards, corresponding to November 2023):

```
gn gen out/Debug
autoninja -C out/Debug chrome
out/Debug/chrome # or on Mac, out/Debug/Chromium.app/Contents/MacOS/Chromium
```

(A component, debug build is recommended for quickest iteration time. This is the default!)

See [How to build Chromium](#) if you aren't already at that point. Be warned: setting up to build Chromium takes time.

It's also recommended that you have Visual Studio code installed.

## About the exercises

This part of the course has a series of exercises which build on each other. We'll be doing them spread throughout the course instead of just at the end. If you don't have time to complete a certain part, don't worry: you can catch up in the next slot.

# Comparing Chromium and Cargo Ecosystems

The Rust community typically uses `cargo` and libraries from [crates.io](https://crates.io). Chromium is built using `gn` and `ninja` and a curated set of dependencies.

When writing code in Rust, your choices are:

- Use `gn` and `ninja` with the help of the templates from `//build/rust/*.gni` (e.g. `rust_static_library` that we'll meet later). This uses Chromium's audited toolchain and `crates`.
- Use `cargo`, but [restrict yourself to Chromium's audited toolchain and crates](#)
- Use `cargo`, trusting a [toolchain](#) and/or [crates downloaded from the internet](#)

From here on we'll be focusing on `gn` and `ninja`, because this is how Rust code can be built into the Chromium browser. At the same time, Cargo is an important part of the Rust ecosystem and you should keep it in your toolbox.

## Mini exercise

Split into small groups and:

- Brainstorm scenarios where `cargo` may offer an advantage and assess the risk profile of these scenarios.
- Discuss which tools, libraries, and groups of people need to be trusted when using `gn` and `ninja`, offline `cargo`, etc.

### ▼ *Speaker Notes*

Ask students to avoid peeking at the speaker notes before completing the exercise. Assuming folks taking the course are physically together, ask them to discuss in small groups of 3-4 people.

Notes/hints related to the first part of the exercise ("scenarios where Cargo may offer an advantage"):

- It's fantastic that when writing a tool, or prototyping a part of Chromium, one has access to the rich ecosystem of `crates.io` libraries. There is a crate for almost anything and they are usually quite pleasant to use. (`c_lap` for command-line parsing, `serde` for



serializing/deserializing to/from various formats, `itertools` for working with iterators, etc.).

- `cargo` makes it easy to try a library (just add a single line to `Cargo.toml` and start writing code)
  - It may be worth comparing how CPAN helped make `perl` a popular choice. Or comparing with `python + pip`.
- Development experience is made really nice not only by core Rust tools (e.g. using `rustup` to switch to a different `rustc` version when testing a crate that needs to work on nightly, current stable, and older stable) but also by an ecosystem of third-party tools (e.g. Mozilla provides `cargo vet` for streamlining and sharing security audits; `criterion` crate gives a streamlined way to run benchmarks).
  - `cargo` makes it easy to add a tool via `cargo install --locked cargo-vet`.
  - It may be worth comparing with Chrome Extensions or VSCode extensions.
- Broad, generic examples of projects where `cargo` may be the right choice:
  - Perhaps surprisingly, Rust is becoming increasingly popular in the industry for writing command line tools. The breadth and ergonomics of libraries is comparable to Python, while being more robust (thanks to the rich typesystem) and running faster (as a compiled, rather than interpreted language).
  - Participating in the Rust ecosystem requires using standard Rust tools like Cargo. Libraries that want to get external contributions, and want to be used outside of Chromium (e.g. in Bazel or Android/Soong build environments) should probably use Cargo.
- Examples of Chromium-related projects that are `cargo`-based:
  - `serde_json_lenient` (experimented with in other parts of Google which resulted in PRs with performance improvements)
  - Fontations libraries like `font-types`
  - `gnrt` tool (we will meet it later in the course) which depends on `clap` for command-line parsing and on `toml` for configuration files.
    - Disclaimer: a unique reason for using `cargo` was unavailability of `gn` when building and bootstrapping Rust standard library when building Rust toolchain.
    - `run_gnrt.py` uses Chromium's copy of `cargo` and `rustc`. `gnrt` depends on third-party libraries downloaded from the internet, but `run_gnrt.py` asks `cargo` that only `--locked` content is allowed via `Cargo.lock`.)

Students may identify the following items as being implicitly or explicitly trusted:

- `rustc` (the Rust compiler) which in turn depends on the LLVM libraries, the Clang compiler, the `rustc` sources (fetched from GitHub, reviewed by Rust compiler team), binary Rust compiler downloaded for bootstrapping
- `rustup` (it may be worth pointing out that `rustup` is developed under the umbrella of the <https://github.com/rust-lang/> organization - same as `rustc` )
- `cargo` , `rustfmt` , etc.
- Various internal infrastructure (bots that build `rustc` , system for distributing the prebuilt toolchain to Chromium engineers, etc.)
- Cargo tools like `cargo audit` , `cargo vet` , etc.
- Rust libraries vendored into `//third_party/rust` (audited by [security@chromium.org](mailto:security@chromium.org))
- Other Rust libraries (some niche, some quite popular and commonly used)

# Chromium Rust policy

Chromium's Rust policy can be found [here](#). Rust can be used for both first-party and third-party code.

Using Rust for pure first-party code looks like this:

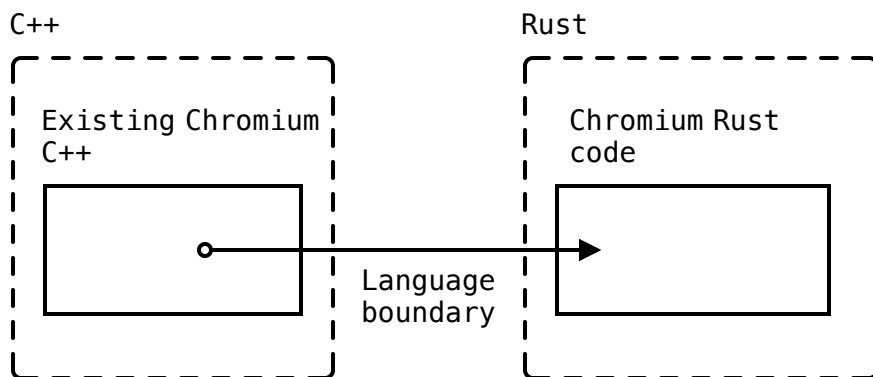

The third-party case is also common. It's likely that you'll also need a small amount of first-party glue code, because very few Rust libraries directly expose a C/C++ API.

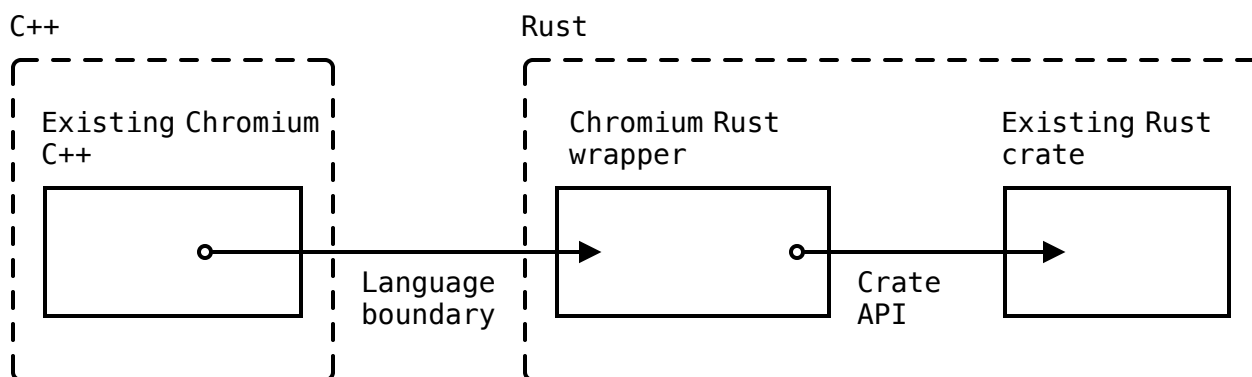

The scenario of using a third-party crate is the more complex one, so today's course will focus on:

- Bringing in third-party Rust libraries ("crates")
- Writing glue code to be able to use those crates from Chromium C++. (The same techniques are used when working with first-party Rust code).

# Build rules

Rust code is usually built using `cargo`. Chromium builds with `gn` and `ninja` for efficiency — its static rules allow maximum parallelism. Rust is no exception.

## Adding Rust code to Chromium

In some existing Chromium `BUILD.gn` file, declare a `rust_static_library`:

```
import("//build/rust/rust_static_library.gni")

rust_static_library("my_rust_lib") {
  crate_root = "lib.rs"
  sources = [ "lib.rs" ]
}
```

You can also add `deps` on other Rust targets. Later we'll use this to depend upon third party code.

### ▼ *Speaker Notes*

You must specify *both* the crate root, *and* a full list of sources. The `crate_root` is the file given to the Rust compiler representing the root file of the compilation unit — typically `lib.rs`. `sources` is a complete list of all source files which `ninja` needs in order to determine when rebuilds are necessary.

(There's no such thing as a Rust `source_set`, because in Rust, an entire crate is a compilation unit. A `static_library` is the smallest unit.)

Students might be wondering why we need a `gn` template, rather than using [gn's built-in support for Rust static libraries](#). The answer is that this template provides support for CXX interop, Rust features, and unit tests, some of which we'll use later.

# Including unsafe Rust Code

Unsafe Rust code is forbidden in `rust_static_library` by default — it won't compile. If you need unsafe Rust code, add `allow_unsafe = true` to the `gn` target. (Later in the course we'll see circumstances where this is necessary.)

```
import("//build/rust/rust_static_library.gni")

rust_static_library("my_rust_lib") {
  crate_root = "lib.rs"
  sources = [
    "lib.rs",
    "hippopotamus.rs"
  ]
  allow_unsafe = true
}
```

# Depending on Rust Code from Chromium C++

Simply add the above target to the `deps` of some Chromium C++ target.

```
import("//build/rust/rust_static_library.gni")

rust_static_library("my_rust_lib") {
  crate_root = "lib.rs"
  sources = [ "lib.rs" ]
}

# or source_set, static_library etc.
component("preexisting_cpp") {
  deps = [ ":my_rust_lib" ]
}
```

## ▼ *Speaker Notes*

We'll see that this relationship only works if the Rust code exposes plain C APIs which can be called from C++, or if we use a C++/Rust interop tool.

# Visual Studio Code

Types are elided in Rust code, which makes a good IDE even more useful than for C++. Visual Studio code works well for Rust in Chromium. To use it,

- Ensure your VSCode has the `rust-analyzer` extension, not earlier forms of Rust support
- `gn gen out/Debug --export-rust-project` (or equivalent for your output directory)
- `ln -s out/Debug/rust-project.json rust-project.json`

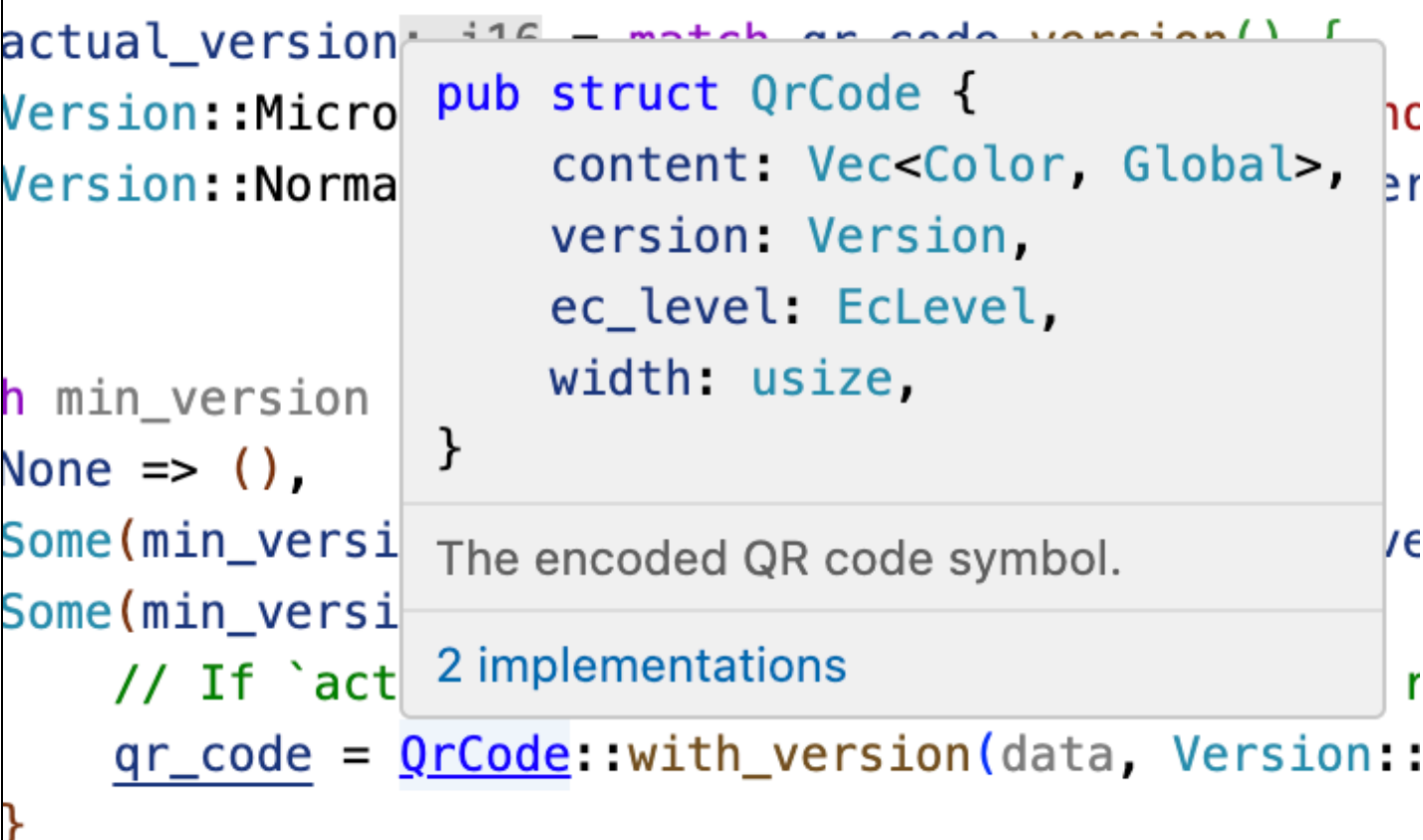

```

actual_version: i16 = match qr_code.version() {
Version::Micro
Version::Norma

h min_version
None => (),
Some(min_versi
Some(min_versi
// If `act
qr_code = QrCode::with_version(data, Version::
}
  
```

```

pub struct QrCode {
    content: Vec<Color, Global>,
    version: Version,
    ec_level: EcLevel,
    width: usize,
}
  
```

The encoded QR code symbol.

2 implementations

## ▼ Speaker Notes

A demo of some of the code annotation and exploration features of `rust-analyzer` might be beneficial if the audience are naturally skeptical of IDEs.

The following steps may help with the demo (but feel free to instead use a piece of Chromium-related Rust that you are most familiar with):

- Open `components/qr_code_generator/qr_code_generator_ffi_glue.rs`
- Place the cursor over the `QrCode::new` call (around line 26) in `qr_code_generator_ffi_glue.rs`
- Demo **show documentation** (typical bindings: `vscode = ctrl k i`; `vim/CoC = K`).

- Demo **go to definition** (typical bindings: vscode = F12; vim/CoC = g d). (This will take you to `//third_party/rust/.../qr_code-.../src/lib.rs`.)
- Demo **outline** and navigate to the `QrCode::with_bits` method (around line 164; the outline is in the file explorer pane in vscode; typical vim/CoC bindings = space o)
- Demo **type annotations** (there are quite a few nice examples in the `QrCode::with_bits` method)

It may be worth pointing out that `gn gen ... --export-rust-project` will need to be rerun after editing `BUILD.gn` files (which we will do a few times throughout the exercises in this session).



# Build rules exercise

In your Chromium build, add a new Rust target to `//ui/base/BUILD.gn` containing:

```
// SAFETY: There is no other global function of this name.
#[unsafe(no_mangle)]
pub extern "C" fn hello_from_rust() {
    println!("Hello from Rust!")
}
```

**Important:** note that `no_mangle` here is considered a type of unsafety by the Rust compiler, so you'll need to allow unsafe code in your `gn` target.

Add this new Rust target as a dependency of `//ui/base:base`. Declare this function at the top of `ui/base/resource/resource_bundle.cc` (later, we'll see how this can be automated by bindings generation tools):

```
extern "C" void hello_from_rust();
```

Call this function from somewhere in `ui/base/resource/resource_bundle.cc` - we suggest the top of `ResourceBundle::MaybeMangleLocalizedString`. Build and run Chromium, and ensure that "Hello from Rust!" is printed lots of times.

If you use VSCode, now set up Rust to work well in VSCode. It will be useful in subsequent exercises. If you've succeeded, you will be able to use right-click "Go to definition" on `println!`.

## Where to find help

- The options available to the [rust\\_static\\_library gn template](#)
- Information about `#[unsafe(no_mangle)]`
- Information about `extern "C"`
- Information about gn's `--export-rust-project` switch
- [How to install rust-analyzer in VSCode](#)

### ▼ *Speaker Notes*

It's really important that students get this running, because future exercises will build on it.

This example is unusual because it boils down to the lowest-common-denominator interop language, C. Both C++ and Rust can natively declare and call C ABI functions. Later in the

course, we'll connect C++ directly to Rust.

`allow_unsafe = true` is required here because `#[unsafe(no_mangle)]` might allow Rust to generate two functions with the same name, and Rust can no longer guarantee that the right one is called.

If you need a pure Rust executable, you can also do that using the `rust_executable` gn template.

# Testing

Rust community typically authors unit tests in a module placed in the same source file as the code being tested. This was covered [earlier](#) in the course and looks like this:

```
#[cfg(test)]
mod tests {
    #[test]
    fn my_test() {
        todo!()
    }
}
```

In Chromium we place unit tests in a separate source file and we continue to follow this practice for Rust — this makes tests consistently discoverable and helps to avoid rebuilding `.rs` files a second time (in the `test` configuration).

This results in the following options for testing Rust code in Chromium:

- Native Rust tests (i.e. `#[test]`). Discouraged outside of `//third_party/rust`.
- `gtest` tests authored in C++ and exercising Rust via FFI calls. Sufficient when Rust code is just a thin FFI layer and the existing unit tests provide sufficient coverage for the feature.
- `gtest` tests authored in Rust and using the crate under test through its public API (using `pub mod for_testing { ... }` if needed). This is the subject of the next few slides.

## ▼ *Speaker Notes*

Mention that native Rust tests of third-party crates should eventually be exercised by Chromium bots. (Such testing is needed rarely — only after adding or updating third-party crates.)

Some examples may help illustrate when C++ `gtest` vs Rust `gtest` should be used:

- QR has very little functionality in the first-party Rust layer (it's just a thin FFI glue) and therefore uses the existing C++ unit tests for testing both the C++ and the Rust implementation (parameterizing the tests so they enable or disable Rust using a `ScopedFeatureList`).
- Hypothetical/WIP PNG integration may need to implement memory-safe implementation of pixel transformations that are provided by `libpng` but missing in the `png` crate - e.g. `RGBA => BGRA`, or gamma correction. Such functionality may benefit from separate tests authored in Rust.

# rust\_gtest\_interop Library

The `rust_gtest_interop` library provides a way to:

- Use a Rust function as a `gtest` testcase (using the `#[gtest(...)]` attribute)
- Use `expect_eq!` and similar macros (similar to `assert_eq!` but not panicking and not terminating the test when the assertion fails).

Example:

```
use rust_gtest_interop::prelude::*;

#[gtest(MyRustTestSuite, MyAdditionTest)]
fn test_addition() {
    expect_eq!(2 + 2, 4);
}
```

# GN Rules for Rust Tests

The simplest way to build Rust `gtest` tests is to add them to an existing test binary that already contains tests authored in C++. For example:

```
test("ui_base_unittests") {  
    ...  
    sources += [ "my_rust_lib_unittest.rs" ]  
    deps += [ ":my_rust_lib" ]  
}
```

Authoring Rust tests in a separate `static_library` also works, but requires manually declaring the dependency on the support libraries:

```
rust_static_library("my_rust_lib_unittests") {  
    testonly = true  
    is_gtest_unittests = true  
    crate_root = "my_rust_lib_unittest.rs"  
    sources = [ "my_rust_lib_unittest.rs" ]  
    deps = [  
        "my_rust_lib",  
        "//testing/rust_gtest_interop",  
    ]  
}  
  
test("ui_base_unittests") {  
    ...  
    deps += [ ":my_rust_lib_unittests" ]  
}
```

# chromium::import! Macro

After adding `:my_rust_lib` to GN `deps`, we still need to learn how to import and use `my_rust_lib` from `my_rust_lib_unittest.rs`. We haven't provided an explicit `crate_name` for `my_rust_lib` so its crate name is computed based on the full target path and name. Fortunately we can avoid working with such an unwieldy name by using the `chromium::import!` macro from the automatically-imported `chromium` crate:

```
chromium::import! {  
    "//ui/base:my_rust_lib";  
}  
  
use my_rust_lib::my_function_under_test;
```

Under the covers the macro expands to something similar to:

```
extern crate ui_sbase_cmy_urust_ulib as my_rust_lib;  
  
use my_rust_lib::my_function_under_test;
```

More information can be found in [the doc comment](#) of the `chromium::import` macro.

## ▼ *Speaker Notes*

`rust_static_library` supports specifying an explicit name via `crate_name` property, but doing this is discouraged. And it is discouraged because the crate name has to be globally unique. `crates.io` guarantees uniqueness of its crate names so `cargo_crate` GN targets (generated by the `gnrt` tool covered in a later section) use short crate names.

# Testing exercise

Time for another exercise!

In your Chromium build:

- Add a testable function next to `hello_from_rust`. Some suggestions: adding two integers received as arguments, computing the *n*th Fibonacci number, summing integers in a slice, etc.
- Add a separate `..._unittest.rs` file with a test for the new function.
- Add the new tests to `BUILD.gn`.
- Build the tests, run them, and verify that the new test works.

# Interoperability with C++

The Rust community offers multiple options for C++/Rust interop, with new tools being developed all the time. At the moment, Chromium uses a tool called CXX.

You describe your whole language boundary in an interface definition language (which looks a lot like Rust) and then CXX tools generate declarations for functions and types in both Rust and C++.

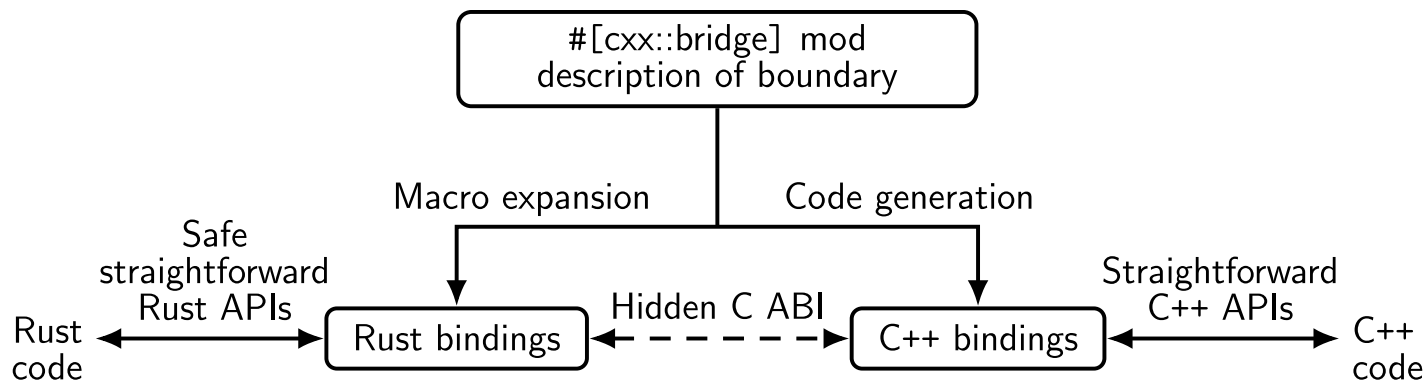

See the [CXX tutorial](#) for a full example of using this.

## ▼ Speaker Notes

Talk through the diagram. Explain that behind the scenes, this is doing just the same as you previously did. Point out that automating the process has the following benefits:

- The tool guarantees that the C++ and Rust sides match (e.g. you get compile errors if the `#[cxx::bridge]` doesn't match the actual C++ or Rust definitions, but with out-of-sync manual bindings you'd get Undefined Behavior)
- The tool automates generation of FFI thunks (small, C-ABI-compatible, free functions) for non-C features (e.g. enabling FFI calls into Rust or C++ methods; manual bindings would require authoring such top-level, free functions manually)
- The tool and the library can handle a set of core types - for example:
  - `&[T]` can be passed across the FFI boundary, even though it doesn't guarantee any particular ABI or memory layout. With manual bindings `std::span<T>` / `&[T]` have to be manually destructured and rebuilt out of a pointer and length - this is error-prone given that each language represents empty slices slightly differently)
  - Smart pointers like `std::unique_ptr<T>`, `std::shared_ptr<T>`, and/or `Box` are natively supported. With manual bindings, one would have to pass C-ABI-compatible raw pointers, which would increase lifetime and memory-safety risks.
  - `rust::String` and `CxxString` types understand and maintain differences in string representation across the languages (e.g. `rust::String::lossy` can build a Rust



string from non-UTF8 input and `rust::String::c_str` can NUL-terminate a string).

# Example Bindings

CXX requires that the whole C++/Rust boundary is declared in `cxx::bridge` modules inside `.rs` source code.

```
#[cxx::bridge]
mod ffi {
    extern "Rust" {
        type MultiBuf;

        fn next_chunk(buf: &mut MultiBuf) -> &[u8];
    }

    unsafe extern "C++" {
        include!("example/include/blobstore.h");

        type BlobstoreClient;

        fn new_blobstore_client() -> UniquePtr<BlobstoreClient>;
        fn put(self: &BlobstoreClient, buf: &mut MultiBuf) -> Result<u64>;
    }
}

// Definitions of Rust types and functions go here
```

## ▼ Speaker Notes

Point out:

- Although this looks like a regular Rust `mod`, the `#[cxx::bridge]` procedural macro does complex things to it. The generated code is quite a bit more sophisticated - though this does still result in a `mod` called `ffi` in your code.
- Native support for C++'s `std::unique_ptr` in Rust
- Native support for Rust slices in C++
- Calls from C++ to Rust, and Rust types (in the top part)
- Calls from Rust to C++, and C++ types (in the bottom part)

**Common misconception:** It *looks* like a C++ header is being parsed by Rust, but this is misleading. This header is never interpreted by Rust, but simply `#include` d in the generated C++ code for the benefit of C++ compilers.

## Limitations of CXX

By far the most useful page when using CXX is the [type reference](#).

CXX fundamentally suits cases where:

- Your Rust-C++ interface is sufficiently simple that you can declare all of it.
- You're using only the types natively supported by CXX already, for example `std::unique_ptr`, `std::string`, `&[u8]` etc.

It has many limitations — for example lack of support for Rust's `option` type.

These limitations constrain us to using Rust in Chromium only for well isolated “leaf nodes” rather than for arbitrary Rust-C++ interop. When considering a use-case for Rust in Chromium, a good starting point is to draft the CXX bindings for the language boundary to see if it appears simple enough.

### ▼ *Speaker Notes*

In addition, right now, Rust code in one component cannot depend on Rust code in another, due to linking details in our component build. That's another reason to restrict Rust to use in leaf nodes.

You should also discuss some of the other sticky points with CXX, for example:

- Its error handling is based around C++ exceptions (given on the next slide)
- Function pointers are awkward to use.

# CXX Error Handling

CXX's support for `Result<T, E>` relies on C++ exceptions, so we can't use that in Chromium.

Alternatives:

- The `T` part of `Result<T, E>` can be:
  - Returned via out parameters (e.g. via `&mut T`). This requires that `T` can be passed across the FFI boundary - for example `T` has to be:
    - A primitive type (like `u32` or `usize`)
    - A type natively supported by `cxx` (like `UniquePtr<T>`) that has a suitable default value to use in a failure case (*unlike* `Box<T>`).
  - Retained on the Rust side, and exposed via reference. This may be needed when `T` is a Rust type, which cannot be passed across the FFI boundary, and cannot be stored in `UniquePtr<T>`.
- The `E` part of `Result<T, E>` can be:
  - Returned as a boolean (e.g. `true` representing success, and `false` representing failure)
  - Preserving error details is in theory possible, but so far hasn't been needed in practice.

# CXX Error Handling: QR Example

The QR code generator is [an example](#) where a boolean is used to communicate success vs failure, and where the successful result can be passed across the FFI boundary:

```
#[cxx::bridge(namespace = "qr_code_generator")]
mod ffi {
    extern "Rust" {
        fn generate_qr_code_using_rust(
            data: &[u8],
            min_version: i16,
            out_pixels: Pin<&mut CxxVector<u8>>,
            out_qr_size: &mut usize,
        ) -> bool;
    }
}
```

## ▼ Speaker Notes

Students may be curious about the semantics of the `out_qr_size` output. This is not the size of the vector, but the size of the QR code (and admittedly it is a bit redundant - this is the square root of the size of the vector).

It may be worth pointing out the importance of initializing `out_qr_size` before calling into the Rust function. Creation of a Rust reference that points to uninitialized memory results in Undefined Behavior (unlike in C++, when only the act of dereferencing such memory results in UB).

If students ask about `Pin`, then explain why CXX needs it for mutable references to C++ data: the answer is that C++ data can't be moved around like Rust data, because it may contain self-referential pointers.

# CXX Error Handling: PNG Example

A prototype of a PNG decoder illustrates what can be done when the successful result cannot be passed across the FFI boundary:

```
#[cxx::bridge(namespace = "gfx::rust_bindings")]
mod ffi {
    extern "Rust" {
        /// This returns an FFI-friendly equivalent of `Result<PngReader<'a>,
        /// ()>`.
        fn new_png_reader<'a>(input: &'a [u8]) -> Box<ResultOfPngReader<'a>>;

        /// C++ bindings for the `crate::png::ResultOfPngReader` type.
        type ResultOfPngReader<'a>;
        fn is_err(self: &ResultOfPngReader) -> bool;
        fn unwrap_as_mut<'a, 'b>(
            self: &'b mut ResultOfPngReader<'a>,
        ) -> &'b mut PngReader<'a>;

        /// C++ bindings for the `crate::png::PngReader` type.
        type PngReader<'a>;
        fn height(self: &PngReader) -> u32;
        fn width(self: &PngReader) -> u32;
        fn read_rgba8(self: &mut PngReader, output: &mut [u8]) -> bool;
    }
}
```

## ▼ Speaker Notes

`PngReader` and `ResultOfPngReader` are Rust types — objects of these types cannot cross the FFI boundary without indirection of a `Box<T>`. We can't have an `out_parameter: &mut PngReader`, because CXX doesn't allow C++ to store Rust objects by value.

This example illustrates that even though CXX doesn't support arbitrary generics nor templates, we can still pass them across the FFI boundary by manually specializing / monomorphizing them into a non-generic type. In the example `ResultOfPngReader` is a non-generic type that forwards into appropriate methods of `Result<T, E>` (e.g. into `is_err`, `unwrap`, and/or `as_mut`).

## Using cxx in Chromium

In Chromium, we define an independent `#[cxx::bridge]` mod for each leaf-node where we want to use Rust. You'd typically have one for each `rust_static_library`. Just add

```
cxx_bindings = [ "my_rust_file.rs" ]
    # list of files containing #[cxx::bridge], not all source files
allow_unsafe = true
```

to your existing `rust_static_library` target alongside `crate_root` and `sources`.

C++ headers will be generated at a sensible location, so you can just

```
#include "ui/base/my_rust_file.rs.h"
```

You will find some utility functions in `//base` to convert to/from Chromium C++ types to CXX Rust types — for example `SpanToRustSlice`.

### ▼ *Speaker Notes*

Students may ask — why do we still need `allow_unsafe = true`?

The broad answer is that no C/C++ code is “safe” by the normal Rust standards. Calling back and forth to C/C++ from Rust may do arbitrary things to memory, and compromise the safety of Rust’s own data layouts. Presence of *too many* `unsafe` keywords in C/C++ interop can harm the signal-to-noise ratio of such a keyword, and is [controversial](#), but strictly, bringing any foreign code into a Rust binary can cause unexpected behavior from Rust’s perspective.

The narrow answer lies in the diagram at the top of [this page](#) — behind the scenes, CXX generates Rust `unsafe` and `extern "C"` functions just like we did manually in the previous section.

# Exercise: Interoperability with C++

## Part one

- In the Rust file you previously created, add a `#[cxx::bridge]` which specifies a single function, to be called from C++, called `hello_from_rust`, taking no parameters and returning no value.
- Modify your previous `hello_from_rust` function to remove `extern "C"` and `#[unsafe(no_mangle)]`. This is now just a standard Rust function.
- Modify your `gn` target to build these bindings.
- In your C++ code, remove the forward-declaration of `hello_from_rust`. Instead, include the generated header file.
- Build and run!

## Part two

It's a good idea to play with CXX a little. It helps you think about how flexible Rust in Chromium actually is.

Some things to try:

- Call back into C++ from Rust. You will need:
  - An additional header file which you can `include!` from your `cxx::bridge`. You'll need to declare your C++ function in that new header file.
  - An `unsafe` block to call such a function, or alternatively specify the `unsafe` keyword in your `#[cxx::bridge]` [as described here](#).
  - You may also need to `#include "third_party/rust/cxx/v1/crate/include/cxx.h"`
- Pass a C++ string from C++ into Rust.
- Pass a reference to a C++ object into Rust.
- Intentionally get the Rust function signatures mismatched from the `#[cxx::bridge]`, and get used to the errors you see.
- Intentionally get the C++ function signatures mismatched from the `#[cxx::bridge]`, and get used to the errors you see.
- Pass a `std::unique_ptr` of some type from C++ into Rust, so that Rust can own some C++ object.
- Create a Rust object and pass it into C++, so that C++ owns it. (Hint: you need a `Box`).



- Declare some methods on a C++ type. Call them from Rust.
- Declare some methods on a Rust type. Call them from C++.

## Part three

Now you understand the strengths and limitations of CXX interop, think of a couple of use-cases for Rust in Chromium where the interface would be sufficiently simple. Sketch how you might define that interface.

## Where to find help

- The [cxx binding reference](#)
- The [rust\\_static\\_library gn template](#)

### ▼ *Speaker Notes*

As students explore Part Two, they're bound to have lots of questions about how to achieve these things, and also how CXX works behind the scenes.

Some of the questions you may encounter:

- I'm seeing a problem initializing a variable of type X with type Y, where X and Y are both function types. This is because your C++ function doesn't quite match the declaration in your `cxx::bridge`.
- I seem to be able to freely convert C++ references into Rust references. Doesn't that risk UB? For CXX's *opaque* types, no, because they are zero-sized. For CXX trivial types yes, it's *possible* to cause UB, although CXX's design makes it quite difficult to craft such an example.

# Adding Third Party Crates

Rust libraries are called “crates” and are found at [crates.io](https://crates.io). It's *very easy* for Rust crates to depend upon one another. So they do!

Property	C++ library	Rust crate
Build system	Lots	Consistent: <code>Cargo.toml</code>
Typical library size	Large-ish	Small
Transitive dependencies	Few	Lots

For a Chromium engineer, this has pros and cons:

- All crates use a common build system so we can automate their inclusion into Chromium...
- ... but, crates typically have transitive dependencies, so you will likely have to bring in multiple libraries.

We'll discuss:

- How to put a crate in the Chromium source code tree
- How to make `gn` build rules for it
- How to audit its source code for sufficient safety.

## ▼ *Speaker Notes*

All of the things in the table on this slide are generalizations, and counter-examples can be found. But in general it's important for students to understand that most Rust code depends on other Rust libraries, because it's easy to do so, and that this has both benefits and costs.

# Configuring the `Cargo.toml` file to add crates

Chromium has a single set of centrally-managed direct crate dependencies. These are managed through a single `Cargo.toml`:

```
[dependencies]
bitflags = "1"
cfg-if = "1"
cxx = "1"
# lots more...
```

As with any other `Cargo.toml`, you can specify [more details about the dependencies](#) — most commonly, you'll want to specify the `features` that you wish to enable in the crate.

When adding a crate to Chromium, you'll often need to provide some extra information in an additional file, `gnrt_config.toml`, which we'll meet next.

# Configuring `gnrt_config.toml`

Alongside `Cargo.toml` is `gnrt_config.toml`. This contains Chromium-specific extensions to crate handling.

If you add a new crate, you should specify at least the `group`. This is one of:

```
# 'safe': The library satisfies the rule-of-2 and can be used in any process.  
# 'sandbox': The library does not satisfy the rule-of-2 and must be used in  
#             a sandboxed process such as the renderer or a utility process.  
# 'test': The library is only used in tests.
```

For instance,

```
[crate.my-new-crate]  
group = 'test' # only used in test code
```

Depending on the crate source code layout, you may also need to use this file to specify where its `LICENSE` file(s) can be found.

Later, we'll see some other things you will need to configure in this file to resolve problems.

# Downloading Crates

A tool called `gnrt` knows how to download crates and how to generate `BUILD.gn` rules.

To start, download the crate you want like this:

```
cd chromium/src
vpython3 tools/crates/run_gnrt.py -- vendor
```

---

Although the `gnrt` tool is part of the Chromium source code, by running this command you will be downloading and running its dependencies from `crates.io`. See [the earlier section](#) discussing this security decision.

---

This `vendor` command may download:

- Your crate
- Direct and transitive dependencies
- New versions of other crates, as required by `cargo` to resolve the complete set of crates required by Chromium.

Chromium maintains patches for some crates, kept in `//third_party/rust/chromium_crates_io/patches`. These will be reapplied automatically, but if patching fails you may need to take manual action.

# Generating gn Build Rules

Once you've downloaded the crate, generate the `BUILD.gn` files like this:

```
vpython3 tools/crates/run_gnrt.py -- gen
```

Now run `git status`. You should find:

- At least one new crate source code in `third_party/rust/chromium_crates_io/vendor`
- At least one new `BUILD.gn` in `third_party/rust/<crate name>/v<major semver version>`
- An appropriate `README.chromium`

The “major semver version” is a [Rust “semver” version number](#).

Take a close look, especially at the things generated in `third_party/rust`.

## ▼ *Speaker Notes*

Talk a little about semver — and specifically the way that in Chromium it's to allow multiple incompatible versions of a crate, which is discouraged but sometimes necessary in the Cargo ecosystem.

# Resolving Problems

If your build fails, it may be because of a `build.rs`: programs which do arbitrary things at build time. This is fundamentally at odds with the design of `gn` and `ninja` which aim for static, deterministic, build rules to maximize parallelism and repeatability of builds.

Some `build.rs` actions are automatically supported; others require action:

<b>build script effect</b>	<b>Supported by our gn templates</b>	<b>Work required by you</b>
Checking rustc version to configure features on and off	Yes	None
Checking platform or CPU to configure features on and off	Yes	None
Generating code	Yes	Yes - specify in <code>gnrt_config.toml</code>
Building C/C++	No	Patch around it
Arbitrary other actions	No	Patch around it

Fortunately, most crates don't contain a build script, and fortunately, most build scripts only do the top two actions.

# Build Scripts Which Generate Code

If `ninja` complains about missing files, check the `build.rs` to see if it writes source code files.

If so, modify `gnrt_config.toml` to add `build-script-outputs` to the crate. If this is a transitive dependency, that is, one on which Chromium code should not directly depend, also add `allow-first-party-usage=false`. There are several examples already in that file:

```
[crate.unicode-linebreak]
allow-first-party-usage = false
build-script-outputs = ["tables.rs"]
```

Now rerun `gnrt.py --gen` to regenerate `BUILD.gn` files to inform `ninja` that this particular output file is input to subsequent build steps.



# Build Scripts Which Build C++ or Take Arbitrary Actions

Some crates use the `cc` crate to build and link C/C++ libraries. Other crates parse C/C++ using `bindgen` within their build scripts. These actions can't be supported in a Chromium context — our `gn`, `ninja` and LLVM build system is very specific in expressing relationships between build actions.

So, your options are:

- Avoid these crates
- Apply a patch to the crate.

Patches should be kept in `third_party/rust/chromium_crates_io/patches/<crate>` - see for example the [patches against the `cxx` crate](#) - and will be applied automatically by `gnrt` each time it upgrades the crate.

# Depending on a Crate

Once you've added a third-party crate and generated build rules, depending on a crate is simple. Find your `rust_static_library` target, and add a `dep` on the `:lib` target within your crate.

Specifically,

```
//third_party/rust crate name /v major semver version :lib
```

For instance,

```
rust_static_library("my_rust_lib") {  
  crate_root = "lib.rs"  
  sources = [ "lib.rs" ]  
  deps = [ "//third_party/rust/example_rust_crate/v1:lib" ]  
}
```

# Auditing Third Party Crates

Adding new libraries is subject to Chromium's standard [policies](#), but of course also subject to security review. As you may be bringing in not just a single crate but also transitive dependencies, there may be a lot of code to review. On the other hand, safe Rust code can have limited negative side effects. How should you review it?

Over time Chromium aims to move to a process based around [cargo vet](#).

Meanwhile, for each new crate addition, we are checking for the following:

- Understand why each crate is used. What's the relationship between crates? If the build system for each crate contains a `build.rs` or procedural macros, work out what they're for. Are they compatible with the way Chromium is normally built?
- Check each crate seems to be reasonably well maintained
- Use `cd third-party/rust/chromium_crates_io; cargo audit` to check for known vulnerabilities (first you'll need to `cargo install cargo-audit`, which ironically involves downloading lots of dependencies from the internet<sup>2</sup>)
- Ensure any `unsafe` code is good enough for the [Rule of Two](#)
- Check for any use of `fs` or `net` APIs
- Read all the code at a sufficient level to look for anything out of place that might have been maliciously inserted. (You can't realistically aim for 100% perfection here: there's often just too much code.)

These are just guidelines — work with reviewers from [security@chromium.org](mailto:security@chromium.org) to work out the right way to become confident of the crate.

# Checking Crates into Chromium Source Code

`git status` should reveal:

- Crate code in `//third_party/rust/chromium_crates_io`
- Metadata (`BUILD.gn` and `README.chromium`) in `//third_party/rust/<crate>/<version>`

Please also add an `OWNERS` file in the latter location.

You should land all this, along with your `cargo.toml` and `gnrt_config.toml` changes, into the Chromium repo.

**Important:** you need to use `git add -f` because otherwise `.gitignore` files may result in some files being skipped.

As you do so, you might find presubmit checks fail because of non-inclusive language. This is because Rust crate data tends to include names of git branches, and many projects still use non-inclusive terminology there. So you may need to run:

```
infra/update_inclusive_language_presubmit_exempt_dirs.sh >
infra/inclusive_language_presubmit_exempt_dirs.txt
git add -p infra/inclusive_language_presubmit_exempt_dirs.txt # add whatever
changes are yours
```

# Keeping Crates Up to Date

As the OWNER of any third party Chromium dependency, you are [expected to keep it up to date with any security fixes](#). It is hoped that we will soon automate this for Rust crates, but for now, it's still your responsibility just as it is for any other third party dependency.

# Exercise

Add `uwuify` to Chromium, turning off the crate's `default features`. Assume that the crate will be used in shipping Chromium, but won't be used to handle untrustworthy input.

(In the next exercise we'll use `uwuify` from Chromium, but feel free to skip ahead and do that now if you like. Or, you could create a new `rust_executable` target which uses `uwuify`).

## ▼ *Speaker Notes*

Students will need to download lots of transitive dependencies.

The total crates needed are:

- `instant`,
- `lock_api`,
- `parking_lot`,
- `parking_lot_core`,
- `redox_syscall`,
- `scopeguard`,
- `smallvec`, and
- `uwuify`.

If students are downloading even more than that, they probably forgot to turn off the default features.

Thanks to [Daniel Liu](#) for this crate!

# Bringing It Together — Exercise

In this exercise, you're going to add a whole new Chromium feature, bringing together everything you already learned.

## The Brief from Product Management

A community of pixies has been discovered living in a remote rainforest. It's important that we get Chromium for Pixies delivered to them as soon as possible.

The requirement is to translate all Chromium's UI strings into Pixie language.

There's not time to wait for proper translations, but fortunately pixie language is very close to English, and it turns out there's a Rust crate which does the translation.

In fact, you already [imported that crate in the previous exercise](#).

(Obviously, real translations of Chrome require incredible care and diligence. Don't ship this!)

## Steps

Modify `ResourceBundle::MaybeMangleLocalizedString` so that it uwuifies all strings before display. In this special build of Chromium, it should always do this irrespective of the setting of `mangle_localized_strings_`.

If you've done everything right across all these exercises, congratulations, you should have created Chrome for pixies!

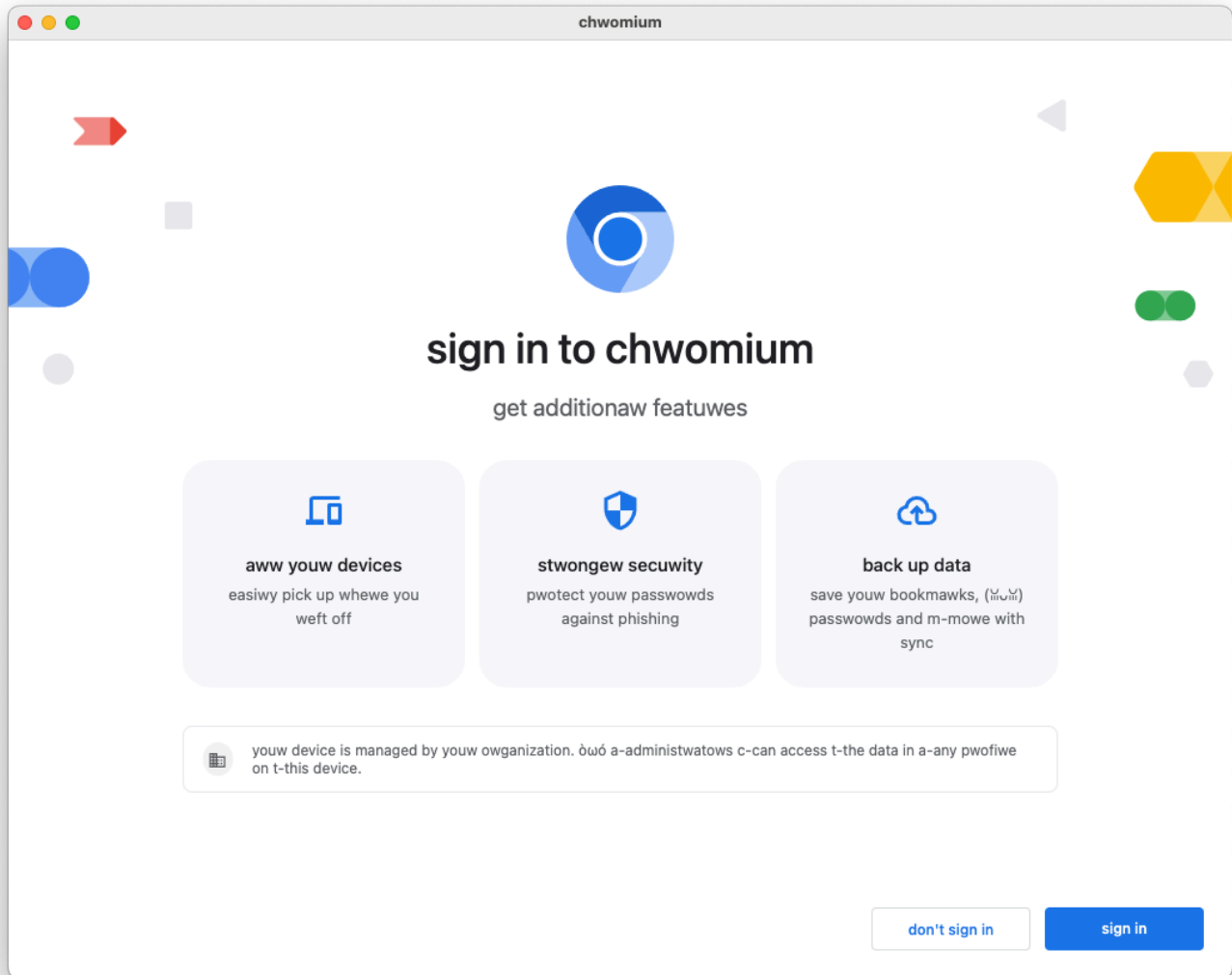

### ▼ Speaker Notes

Students will likely need some hints here. Hints include:

- UTF16 vs UTF8. Students should be aware that Rust strings are always UTF8, and will probably decide that it's better to do the conversion on the C++ side using `base::UTF16ToUTF8` and back again.
- If students decide to do the conversion on the Rust side, they'll need to consider `String::from_utf16`, consider error handling, and consider which [CXX supported types can transfer a lot of u16s](#).
- Students may design the C++/Rust boundary in several different ways, e.g. taking and returning strings by value, or taking a mutable reference to a string. If a mutable reference is used, CXX will likely tell the student that they need to use `Pin`. You may need to explain what `Pin` does, and then explain why CXX needs it for mutable references to C++ data: the answer is that C++ data can't be moved around like Rust data, because it may contain self-referential pointers.



- The C++ target containing `ResourceBundle::MaybeMangleLocalizedString` will need to depend on a `rust_static_library` target. The student probably already did this.
- The `rust_static_library` target will need to depend on `//third_party/rust/uwuiify/v0_2:lib`.

# Exercise Solutions

Solutions to the Chromium exercises can be found in [this series of CLs](#).

# Welcome to Bare Metal Rust

This is a standalone one-day course about bare-metal Rust, aimed at people who are familiar with the basics of Rust (perhaps from completing the Comprehensive Rust course), and ideally also have some experience with bare-metal programming in some other language such as C.

Today we will talk about 'bare-metal' Rust: running Rust code without an OS underneath us. This will be divided into several parts:

- What is `no_std` Rust?
- Writing firmware for microcontrollers.
- Writing bootloader / kernel code for application processors.
- Some useful crates for bare-metal Rust development.

For the microcontroller part of the course we will use the [BBC micro:bit v2](#) as an example. It's a [development board](#) based on the Nordic nRF52833 microcontroller with some LEDs and buttons, an I2C-connected accelerometer and compass, and an on-board SWD debugger.

To get started, install some tools we'll need later. On gLinux or Debian:

```
sudo apt install gdb-multiarch libudev-dev picocom pkg-config qemu-system-arm
build-essential
rustup update
rustup target add aarch64-unknown-none thumbv7em-none-eabihf
rustup component add llvm-tools-preview
cargo install cargo-binutils
curl --proto 'https' --tlsv1.2 -Lsf https://github.com/probe-rs/probe-rs/releases/latest/download/probe-rs-tools-installer.sh | sh
```

And give users in the `plugdev` group access to the micro:bit programmer:

```
echo 'SUBSYSTEM=="hidraw", ATTRS{idVendor}=="0d28", MODE="0660",
GROUP="logind", TAG+="uaccess" | \
sudo tee /etc/udev/rules.d/50-microbit.rules
sudo udevadm control --reload-rules
```

You should see "NXP ARM mbed" in the output of `lsusb` if the device is available. If you are using a Linux environment on a Chromebook, you will need to share the USB device with Linux, via `chrome://os-settings/crostini/sharedUsbDevices`.

On MacOS:

```
xcode-select --install  
brew install gdb picocom qemu  
rustup update  
rustup target add aarch64-unknown-none thumbv7em-none-eabihf  
rustup component add llvm-tools-preview  
cargo install cargo-binutils  
curl --proto 'https' --tlsv1.2 -LsSf https://github.com/probe-rs/probe-  
rs/releases/latest/download/probe-rs-tools-installer.sh | sh
```

# no\_std

## core

- Slices, &str, CStr
- NonZeroU8 ...
- Option, Result
- Display, Debug, write! ...
- Iterator
- Error
- panic!, assert\_eq! ...
- NonNull and all the usual pointer-related functions
- Future and async / await
- fence, AtomicBool, AtomicPtr, AtomicU32 ...
- Duration

## alloc

- Box, Cow, Arc, Rc
- Vec, BinaryHeap, BtreeMap, LinkedList, VecDeque
- String, CString, format!

## std

- HashMap
- Mutex, Condvar, Barrier, Once, RwLock, mpsc
- File and the rest of fs
- println!, Read, Write, Stdin, Stdout and the rest of io
- Path, OsString
- net
- Command, Child, ExitCode
- spawn, sleep and the rest of thread
- SystemTime, Instant

### ▼ *Speaker Notes*

- HashMap depends on RNG.
- std re-exports the contents of both core and alloc.

# A minimal `no_std` program

```
1 #![no_main]
2 #![no_std]
3
4 use core::panic::PanicInfo;
5
6 #[panic_handler]
7 fn panic(_panic: &PanicInfo) -> ! {
8     loop {}
9 }
```

## ▼ *Speaker Notes*

- This will compile to an empty binary.
- `std` provides a panic handler; without it we must provide our own.
- It can also be provided by another crate, such as `panic-halt`.
- Depending on the target, you may need to compile with `panic = "abort"` to avoid an error about `eh_personality`.
- Note that there is no `main` or any other entry point; it's up to you to define your own entry point. This will typically involve a linker script and some assembly code to set things up ready for Rust code to run.

# alloc

To use `alloc` you must implement a [global \(heap\) allocator](#).

```

1  #![no_main]
2  #![no_std]
3
4  extern crate alloc;
5  extern crate panic_halt as _;
6
7  use alloc::string::ToString;
8  use alloc::vec::Vec;
9  use buddy_system_allocator::LockedHeap;
10
11 #[global_allocator]
12 static HEAP_ALLOCATOR: LockedHeap<32> = LockedHeap::<32>::new();
13
14 static mut HEAP: [u8; 65536] = [0; 65536];
15
16 pub fn entry() {
17     // SAFETY: `HEAP` is only used here and `entry` is only called once.
18     unsafe {
19         // Give the allocator some memory to allocate.
20         HEAP_ALLOCATOR.lock().init(HEAP.as_mut_ptr() as usize, HEAP.len());
21     }
22
23     // Now we can do things that require heap allocation.
24     let mut v = Vec::new();
25     v.push("A string".to_string());
26 }

```

## ▼ Speaker Notes

- `buddy_system_allocator` is a crate implementing a basic buddy system allocator. Other crates are available, or you can write your own or hook into your existing allocator.
- The const parameter of `LockedHeap` is the max order of the allocator; i.e. in this case it can allocate regions of up to  $2^{*}32$  bytes.
- If any crate in your dependency tree depends on `alloc` then you must have exactly one global allocator defined in your binary. Usually this is done in the top-level binary crate.
- `extern crate panic_halt as _` is necessary to ensure that the `panic_halt` crate is linked in so we get its panic handler.
- This example will build but not run, as it doesn't have an entry point.

# Microcontrollers

The `cortex_m_rt` crate provides (among other things) a reset handler for Cortex M microcontrollers.

```
1  #![no_main]
2  #![no_std]
3
4  extern crate panic_halt as _;
5
6  mod interrupts;
7
8  use cortex_m_rt::entry;
9
10 #[entry]
11 fn main() -> ! {
12     loop {}
13 }
```

Next we'll look at how to access peripherals, with increasing levels of abstraction.

## ▼ *Speaker Notes*

- The `cortex_m_rt::entry` macro requires that the function have type `fn() -> !`, because returning to the reset handler doesn't make sense.
- Run the example with `cargo embed --bin minimal`



# Raw MMIO

Most microcontrollers access peripherals via memory-mapped IO. Let's try turning on an LED on our micro:bit:

```

1  #![no_main]
2  #![no_std]
3
4  extern crate panic_halt as _;
5
6  mod interrupts;
7
8  use core::mem::size_of;
9  use cortex_m_rt::entry;
10
11  /// GPIO port 0 peripheral address
12  const GPIO_P0: usize = 0x5000_0000;
13
14  // GPIO peripheral offsets
15  const PIN_CNF: usize = 0x700;
16  const OUTSET: usize = 0x508;
17  const OUTCLR: usize = 0x50c;
18
19  // PIN_CNF fields
20  const DIR_OUTPUT: u32 = 0x1;
21  const INPUT_DISCONNECT: u32 = 0x1 << 1;
22  const PULL_DISABLED: u32 = 0x0 << 2;
23  const DRIVE_S0S1: u32 = 0x0 << 8;
24  const SENSE_DISABLED: u32 = 0x0 << 16;
25
26  #[entry]
27  fn main() -> ! {
28      // Configure GPIO 0 pins 21 and 28 as push-pull outputs.
29      let pin_cnf_21 = (GPIO_P0 + PIN_CNF + 21 * size_of::<u32>()) as *mut u32;
30      let pin_cnf_28 = (GPIO_P0 + PIN_CNF + 28 * size_of::<u32>()) as *mut u32;
31      // SAFETY: The pointers are to valid peripheral control registers, and no
32      // aliases exist.
33      unsafe {
34          pin_cnf_21.write_volatile(
35              DIR_OUTPUT
36              | INPUT_DISCONNECT
37              | PULL_DISABLED
38              | DRIVE_S0S1
39              | SENSE_DISABLED,
40          );
41          pin_cnf_28.write_volatile(
42              DIR_OUTPUT
43              | INPUT_DISCONNECT
44              | PULL_DISABLED
45              | DRIVE_S0S1
46              | SENSE_DISABLED,
47          );
48      }
49
50      // Set pin 28 low and pin 21 high to turn the LED on.
51      let gpio0_outset = (GPIO_P0 + OUTSET) as *mut u32;
52      let gpio0_outclr = (GPIO_P0 + OUTCLR) as *mut u32;
53      // SAFETY: The pointers are to valid peripheral control registers, and no
54      // aliases exist.
55      unsafe {

```

```
55         unsafe {
56             gpio0_outclr.write_volatile(1 << 28);
57             gpio0_outset.write_volatile(1 << 21);
58         }
59
60     loop {}
61 }
```

### ▼ *Speaker Notes*

- GPIO 0 pin 21 is connected to the first column of the LED matrix, and pin 28 to the first row.

Run the example with:

```
cargo embed --bin mmio
```

# Peripheral Access Crates

`svd2rust` generates mostly-safe Rust wrappers for memory-mapped peripherals from CMSIS-SVD files.

```
1  #![no_main]
2  #![no_std]
3
4  extern crate panic_halt as _;
5
6  use cortex_m_rt::entry;
7  use nrf52833_pac::Peripherals;
8
9  #[entry]
10 fn main() -> ! {
11     let p = Peripherals::take().unwrap();
12     let gpio0 = p.P0;
13
14     // Configure GPIO 0 pins 21 and 28 as push-pull outputs.
15     gpio0.pin_cnf[21].write(|w| {
16         w.dir().output();
17         w.input().disconnect();
18         w.pull().disabled();
19         w.drive().s0s1();
20         w.sense().disabled();
21         w
22     });
23     gpio0.pin_cnf[28].write(|w| {
24         w.dir().output();
25         w.input().disconnect();
26         w.pull().disabled();
27         w.drive().s0s1();
28         w.sense().disabled();
29         w
30     });
31
32     // Set pin 28 low and pin 21 high to turn the LED on.
33     gpio0.outclr.write(|w| w.pin28().clear());
34     gpio0.outset.write(|w| w.pin21().set());
35
36     loop {}
37 }
```

## ▼ Speaker Notes

- SVD (System View Description) files are XML files typically provided by silicon vendors which describe the memory map of the device.

- They are organised by peripheral, register, field and value, with names, descriptions, addresses and so on.
- SVD files are often buggy and incomplete, so there are various projects which patch the mistakes, add missing details, and publish the generated crates.
- `cortex-m-rt` provides the vector table, among other things.
- If you `cargo install cargo-binutils` then you can run `cargo objdump --bin pac -- -d --no-show-raw-insn` to see the resulting binary.

Run the example with:

```
cargo embed --bin pac
```

# HAL crates

HAL crates for many microcontrollers provide wrappers around various peripherals. These generally implement traits from [embedded-hal](#).

```
1  #![no_main]
2  #![no_std]
3
4  extern crate panic_halt as _;
5
6  use cortex_m_rt::entry;
7  use embedded_hal::digital::OutputPin;
8  use nrf52833_hal::gpio::{p0, Level};
9  use nrf52833_hal::pac::Peripherals;
10
11 #[entry]
12 fn main() -> ! {
13     let p = Peripherals::take().unwrap();
14
15     // Create HAL wrapper for GPIO port 0.
16     let gpio0 = p0::Parts::new(p.P0);
17
18     // Configure GPIO 0 pins 21 and 28 as push-pull outputs.
19     let mut col1 = gpio0.p0_28.into_push_pull_output(Level::High);
20     let mut row1 = gpio0.p0_21.into_push_pull_output(Level::Low);
21
22     // Set pin 28 low and pin 21 high to turn the LED on.
23     col1.set_low().unwrap();
24     row1.set_high().unwrap();
25
26     loop {}
27 }
```

## ▼ Speaker Notes

- `set_low` and `set_high` are methods on the `embedded_hal OutputPin` trait.
- HAL crates exist for many Cortex-M and RISC-V devices, including various STM32, GD32, nRF, NXP, MSP430, AVR and PIC microcontrollers.

Run the example with:

```
cargo embed --bin hal
```

# Board support crates

Board support crates provide a further level of wrapping for a specific board for convenience.

```
1  #![no_main]
2  #![no_std]
3
4  extern crate panic_halt as _;
5
6  use cortex_m_rt::entry;
7  use embedded_hal::digital::OutputPin;
8  use microbit::Board;
9
10 #[entry]
11 fn main() -> ! {
12     let mut board = Board::take().unwrap();
13
14     board.display_pins.col1.set_low().unwrap();
15     board.display_pins.row1.set_high().unwrap();
16
17     loop {}
18 }
```

## ▼ *Speaker Notes*

- In this case the board support crate is just providing more useful names, and a bit of initialisation.
- The crate may also include drivers for some on-board devices outside of the microcontroller itself.
  - `microbit-v2` includes a simple driver for the LED matrix.

Run the example with:

```
cargo embed --bin board_support
```

# The type state pattern

```

1  #[entry]
2  fn main() -> ! {
3      let p = Peripherals::take().unwrap();
4      let gpio0 = p0::Parts::new(p.P0);
5
6      let pin: P0_01<Disconnected> = gpio0.p0_01;
7
8      // let gpio0_01_again = gpio0.p0_01; // Error, moved.
9      let mut pin_input: P0_01<Input<Floating>> = pin.into_floating_input();
10     if pin_input.is_high().unwrap() {
11         // ...
12     }
13     let mut pin_output: P0_01<Output<OpenDrain>> = pin_input
14         .into_open_drain_output(OpenDrainConfig::Disconnect0Standard1, Level::
15 pin_output.set_high().unwrap();
16     // pin_input.is_high(); // Error, moved.
17
18     let _pin2: P0_02<Output<OpenDrain>> = gpio0
19         .p0_02
20         .into_open_drain_output(OpenDrainConfig::Disconnect0Standard1, Level::
21     let _pin3: P0_03<Output<PushPull>> =
22         gpio0.p0_03.into_push_pull_output(Level::Low);
23
24     loop {}
25 }

```

## ▼ Speaker Notes

- Pins don't implement `Copy` or `Clone`, so only one instance of each can exist. Once a pin is moved out of the port struct nobody else can take it.
- Changing the configuration of a pin consumes the old pin instance, so you can't keep use the old instance afterwards.
- The type of a value indicates the state that it is in: e.g. in this case, the configuration state of a GPIO pin. This encodes the state machine into the type system, and ensures that you don't try to use a pin in a certain way without properly configuring it first. Illegal state transitions are caught at compile time.
- You can call `is_high` on an input pin and `set_high` on an output pin, but not vice-versa.
- Many HAL crates follow this pattern.



# embedded-hal

The `embedded-hal` crate provides a number of traits covering common microcontroller peripherals:

- GPIO
- PWM
- Delay timers
- I2C and SPI buses and devices

Similar traits for byte streams (e.g. UARTs), CAN buses and RNGs and broken out into `embedded-io`, `embedded-can` and `rand_core` respectively.

Other crates then implement `drivers` in terms of these traits, e.g. an accelerometer driver might need an I2C or SPI device instance.

## ▼ *Speaker Notes*

- The traits cover using the peripherals but not initialising or configuring them, as initialisation and configuration is usually highly platform-specific.
- There are implementations for many microcontrollers, as well as other platforms such as Linux on Raspberry Pi.
- `embedded-hal-async` provides async versions of the traits.
- `embedded-hal-nb` provides another approach to non-blocking I/O, based on the `nb` crate.

# probe-rs and cargo-embed

`probe-rs` is a handy toolset for embedded debugging, like OpenOCD but better integrated.

- SWD (Serial Wire Debug) and JTAG via CMSIS-DAP, ST-Link and J-Link probes
- GDB stub and Microsoft DAP (Debug Adapter Protocol) server
- Cargo integration

`cargo-embed` is a cargo subcommand to build and flash binaries, log RTT (Real Time Transfers) output and connect GDB. It's configured by an `Embed.toml` file in your project directory.

## ▼ *Speaker Notes*

- [CMSIS-DAP](#) is an Arm standard protocol over USB for an in-circuit debugger to access the CoreSight Debug Access Port of various Arm Cortex processors. It's what the on-board debugger on the BBC micro:bit uses.
- ST-Link is a range of in-circuit debuggers from ST Microelectronics, J-Link is a range from SEGGER.
- The Debug Access Port is usually either a 5-pin JTAG interface or 2-pin Serial Wire Debug.
- `probe-rs` is a library which you can integrate into your own tools if you want to.
- The [Microsoft Debug Adapter Protocol](#) lets VSCode and other IDEs debug code running on any supported microcontroller.
- `cargo-embed` is a binary built using the `probe-rs` library.
- RTT (Real Time Transfers) is a mechanism to transfer data between the debug host and the target through a number of ringbuffers.

# Debugging

*Embed.toml:*

```
[default.general]
chip = "nrf52833_xxAA"

[debug.gdb]
enabled = true
```

In one terminal under `src/bare-metal/microcontrollers/examples/`:

```
cargo embed --bin board_support debug
```

In another terminal in the same directory:

On gLinux or Debian:

```
gdb-multiarch target/thumbv7em-none-eabihf/debug/board_support --eval-
command="target remote :1337"
```

On MacOS:

```
arm-none-eabi-gdb target/thumbv7em-none-eabihf/debug/board_support --eval-
command="target remote :1337"
```

## ▼ *Speaker Notes*

In GDB, try running:

```
b src/bin/board_support.rs:29
b src/bin/board_support.rs:30
b src/bin/board_support.rs:32
c
c
c
```

# Other projects

- [RTIC](#)
  - “Real-Time Interrupt-driven Concurrency”.
  - Shared resource management, message passing, task scheduling, timer queue.
- [Embassy](#)
  - `async` executors with priorities, timers, networking, USB.
- [TockOS](#)
  - Security-focused RTOS with preemptive scheduling and Memory Protection Unit support.
- [Hubris](#)
  - Microkernel RTOS from Oxide Computer Company with memory protection, unprivileged drivers, IPC.
- [Bindings for FreeRTOS](#).

Some platforms have `std` implementations, e.g. [esp-idf](#).

## ▼ *Speaker Notes*

- RTIC can be considered either an RTOS or a concurrency framework.
  - It doesn't include any HALs.
  - It uses the Cortex-M NVIC (Nested Virtual Interrupt Controller) for scheduling rather than a proper kernel.
  - Cortex-M only.
- Google uses TockOS on the Haven microcontroller for Titan security keys.
- FreeRTOS is mostly written in C, but there are Rust bindings for writing applications.

# Exercises

We will read the direction from an I2C compass, and log the readings to a serial port.

## ▼ *Speaker Notes*

After looking at the exercises, you can look at the [solutions](#) provided.

# Compass

We will read the direction from an I2C compass, and log the readings to a serial port. If you have time, try displaying it on the LEDs somehow too, or use the buttons somehow.

Hints:

- Check the documentation for the [lsm303agr](#) and [microbit-v2](#) crates, as well as the [micro:bit hardware](#).
- The LSM303AGR Inertial Measurement Unit is connected to the internal I2C bus.
- TWI is another name for I2C, so the I2C master peripheral is called TWIM.
- The LSM303AGR driver needs something implementing the `embedded_hal::i2c::I2c` trait. The `microbit::hal::Twim` struct implements this.
- You have a `microbit::Board` struct with fields for the various pins and peripherals.
- You can also look at the [nRF52833 datasheet](#) if you want, but it shouldn't be necessary for this exercise.

Download the [exercise template](#) and look in the `compass` directory for the following files.

*src/main.rs:*

```

#![no_main]
#![no_std]

extern crate panic_halt as _;

use core::fmt::Write;
use cortex_m_rt::entry;
use microbit::{hal::{Delay, uarte::{Baudrate, Parity, Uarte}}, Board};

#[entry]
fn main() -> ! {
    let mut board = Board::take().unwrap();

    // Configure serial port.
    let mut serial = Uarte::new(
        board.UARTE0,
        board.uart.into(),
        Parity::EXCLUDED,
        Baudrate::BAUD115200,
    );

    // Use the system timer as a delay provider.
    let mut delay = Delay::new(board.SYST);

    // Set up the I2C controller and Inertial Measurement Unit.
    // TODO

    writeln!(serial, "Ready.").unwrap();

    loop {
        // Read compass data and log it to the serial port.
        // TODO
    }
}

```

*Cargo.toml* (you shouldn't need to change this):

```

[workspace]

[package]
name = "compass"
version = "0.1.0"
edition = "2021"
publish = false

[dependencies]
cortex-m-rt = "0.7.5"
embedded-hal = "1.0.0"
lsm303agr = "1.1.0"
microbit-v2 = "0.15.1"
panic-halt = "1.0.0"

```

*Embed.toml* (you shouldn't need to change this):

```
[default.general]
chip = "nrf52833_xxAA"

[debug.gdb]
enabled = true

[debug.reset]
halt_afterwards = true
```

*.cargo/config.toml* (you shouldn't need to change this):

```
[build]
target = "thumbv7em-none-eabihf" # Cortex-M4F

[target.'cfg(all(target_arch = "arm", target_os = "none"))']
rustflags = ["-C", "link-arg=-Tlink.x"]
```

See the serial output on Linux with:

```
picocom --baud 115200 --imap lfcrLf /dev/ttyACM0
```

Or on Mac OS something like (the device name may be slightly different):

```
picocom --baud 115200 --imap lfcrLf /dev/tty.usbmodem14502
```

Use Ctrl+A Ctrl+Q to quit picocom.



# Bare Metal Rust Morning Exercise

## Compass

[\(back to exercise\)](#)

```

#![no_main]
#![no_std]

extern crate panic_halt as _;

use core::fmt::Write;
use cortex_m_rt::entry;
use embedded_hal::digital::InputPin;
use lsm303agr::{
    AccelMode, AccelOutputDataRate, Lsm303agr, MagMode, MagOutputDataRate,
};
use microbit::display::blocking::Display;
use microbit::hal::twim::Twim;
use microbit::hal::uarte::{Baudrate, Parity, Uarte};
use microbit::hal::{Delay, Timer};
use microbit::pac::twim0::frequency::FREQUENCY_A;
use microbit::Board;

const COMPASS_SCALE: i32 = 30000;
const ACCELEROMETER_SCALE: i32 = 700;

#[entry]
fn main() -> ! {
    let mut board = Board::take().unwrap();

    // Configure serial port.
    let mut serial = Uarte::new(
        board.UARTE0,
        board.uart.into(),
        Parity::EXCLUDED,
        Baudrate::BAUD115200,
    );

    // Use the system timer as a delay provider.
    let mut delay = Delay::new(board.SYST);

    // Set up the I2C controller and Inertial Measurement Unit.
    writeln!(serial, "Setting up IMU...").unwrap();
    let i2c = Twim::new(board.TWIM0, board.i2c_internal.into(),
FREQUENCY_A::K100);
    let mut imu = Lsm303agr::new_with_i2c(i2c);
    imu.init().unwrap();
    imu.set_mag_mode_and_odr(
        &mut delay,
        MagMode::HighResolution,
        MagOutputDataRate::Hz50,
    )
    .unwrap();
    imu.set_accel_mode_and_odr(
        &mut delay,
        AccelMode::Normal,
        AccelOutputDataRate::Hz50,
    )
    .unwrap();
}

```

```

let mut imu = imu.into_mag_continuous().ok().unwrap();

// Set up display and timer.
let mut timer = Timer::new(board.TIMER0);
let mut display = Display::new(board.display_pins);

let mut mode = Mode::Compass;
let mut button_pressed = false;

writeln!(serial, "Ready.").unwrap();

loop {
    // Read compass data and log it to the serial port.
    while !(imu.mag_status().unwrap().xyz_new_data()
        && imu.accel_status().unwrap().xyz_new_data())
    {}
    let compass_reading = imu.magnetic_field().unwrap();
    let accelerometer_reading = imu.acceleration().unwrap();
    writeln!(
        serial,
        "{}\t{}\t{}\t{}\t{}\t{}\t{}\t{}\t{}\t{}\t{}\t{}\t{}\t{}\t{}\t{}\t{}\t{}\t{}\t{}",
        compass_reading.x_nt(),
        compass_reading.y_nt(),
        compass_reading.z_nt(),
        accelerometer_reading.x_mg(),
        accelerometer_reading.y_mg(),
        accelerometer_reading.z_mg(),
    )
    .unwrap();

    let mut image = [[0; 5]; 5];
    let (x, y) = match mode {
        Mode::Compass => (
            scale(-compass_reading.x_nt(), -COMPASS_SCALE, COMPASS_SCALE, 0,
4)
                as usize,
            scale(compass_reading.y_nt(), -COMPASS_SCALE, COMPASS_SCALE, 0,
4)
                as usize,
        ),
        Mode::Accelerometer => (
            scale(
                accelerometer_reading.x_mg(),
                -ACCELEROMETER_SCALE,
                ACCELEROMETER_SCALE,
                0,
                4,
            ) as usize,
            scale(
                -accelerometer_reading.y_mg(),
                -ACCELEROMETER_SCALE,
                ACCELEROMETER_SCALE,
                0,
                4,
            ) as usize,
        ),
    }
}

```

```

        ) as usize,
    ),
};
image[y][x] = 255;
display.show(&mut timer, image, 100);

// If button A is pressed, switch to the next mode and briefly blink all
LEDS
// on.
if board.buttons.button_a.is_low().unwrap() {
    if !button_pressed {
        mode = mode.next();
        display.show(&mut timer, [[255; 5]; 5], 200);
    }
    button_pressed = true;
} else {
    button_pressed = false;
}
}
}

#[derive(Copy, Clone, Debug, Eq, PartialEq)]
enum Mode {
    Compass,
    Accelerometer,
}

impl Mode {
    fn next(self) -> Self {
        match self {
            Self::Compass => Self::Accelerometer,
            Self::Accelerometer => Self::Compass,
        }
    }
}

fn scale(value: i32, min_in: i32, max_in: i32, min_out: i32, max_out: i32) -> i32
{
    let range_in = max_in - min_in;
    let range_out = max_out - min_out;
    let scaled = min_out + range_out * (value - min_in) / range_in;
    scaled.clamp(min_out, max_out)
}

```

# Application processors

So far we've talked about microcontrollers, such as the Arm Cortex-M series. These are typically small systems with very limited resources.

Larger systems with more resources are typically called application processors, built around processors such as the ARM Cortex-A or Intel Atom.

For simplicity we'll just work with QEMU's aarch64 `'virt'` board.

## ▼ *Speaker Notes*

- Broadly speaking, microcontrollers don't have an MMU or multiple levels of privilege (exception levels on Arm CPUs, rings on x86).
- Application processors have more resources, and often run an operating system, instead of directly executing the target application on startup.
- QEMU supports emulating various different machines or board models for each architecture. The `'virt'` board doesn't correspond to any particular real hardware, but is designed purely for virtual machines.
- We will still address this board as bare-metal, as if we were writing an operating system.

# Getting Ready to Rust

Before we can start running Rust code, we need to do some initialisation.

```

/**
 * This is a generic entry point for an image. It carries out the
 * operations required to prepare the loaded image to be run.
 * Specifically, it
 *
 * - sets up the MMU with an identity map of virtual to physical
 *   addresses, and enables caching
 * - enables floating point
 * - zeroes the bss section using registers x25 and above
 * - prepares the stack, pointing to a section within the image
 * - sets up the exception vector
 * - branches to the Rust `main` function
 *
 * It preserves x0-x3 for the Rust entry point, as these may contain
 * boot parameters.
 */
.section .init.entry, "ax"
.global entry
entry:
    /*
     * Load and apply the memory management configuration, ready to
     * enable MMU and caches.
     */
    adrp x30, idmap
    msr ttbr0_el1, x30

    mov_i x30, .Lmairval
    msr mair_el1, x30

    mov_i x30, .Ltcrval
    /* Copy the supported PA range into TCR_EL1.IPS. */
    mrs x29, id_aa64mmfr0_el1
    bfi x30, x29, #32, #4

    msr tcr_el1, x30

    mov_i x30, .Lsctlrval

    /*
     * Ensure everything before this point has completed, then
     * invalidate any potentially stale local TLB entries before they
     * start being used.
     */
    isb
    tlbi vmalle1
    ic iallu
    dsb nsh
    isb

    /*
     * Configure sctlr_el1 to enable MMU and cache and don't proceed
     * until this has completed.
     */
    msr sctlr_el1, x30

```

```
isb
```

```
/* Disable trapping floating point access in EL1. */
mrs x30, cpacr_el1
orr x30, x30, #(0x3 << 20)
msr cpacr_el1, x30
isb
```

```
/* Zero out the bss section. */
adr_l x29, bss_begin
adr_l x30, bss_end
```

```
0: cmp x29, x30
   b.hs 1f
   stp xzr, xzr, [x29], #16
   b 0b
```

```
1: /* Prepare the stack. */
   adr_l x30, boot_stack_end
   mov sp, x30
```

```
/* Set up exception vector. */
adr x30, vector_table_el1
msr vbar_el1, x30
```

```
/* Call into Rust code. */
bl main
```

```
/* Loop forever waiting for interrupts. */
2: wfi
   b 2b
```

### ▼ *Speaker Notes*

This code is in `src/bare-metal/aps/examples/entry.s`. It's not necessary to understand this in detail – the takeaway is that typically some low-level setup is needed to meet Rust's expectations of the system.

- This is the same as it would be for C: initialising the processor state, zeroing the BSS, and setting up the stack pointer.
  - The BSS (block starting symbol, for historical reasons) is the part of the object file which containing statically allocated variables which are initialised to zero. They are omitted from the image, to avoid wasting space on zeroes. The compiler assumes that the loader will take care of zeroing them.
- The BSS may already be zeroed, depending on how memory is initialised and the image is loaded, but we zero it to be sure.
- We need to enable the MMU and cache before reading or writing any memory. If we don't:



- Unaligned accesses will fault. We build the Rust code for the `aarch64-unknown-none` target which sets `+strict-align` to prevent the compiler generating unaligned accesses, so it should be fine in this case, but this is not necessarily the case in general.
- If it were running in a VM, this can lead to cache coherency issues. The problem is that the VM is accessing memory directly with the cache disabled, while the host has cacheable aliases to the same memory. Even if the host doesn't explicitly access the memory, speculative accesses can lead to cache fills, and then changes from one or the other will get lost when the cache is cleaned or the VM enables the cache. (Cache is keyed by physical address, not VA or IPA.)
- For simplicity, we just use a hardcoded pagetable (see `idmap.s`) which identity maps the first 1 GiB of address space for devices, the next 1 GiB for DRAM, and another 1 GiB higher up for more devices. This matches the memory layout that QEMU uses.
- We also set up the exception vector (`vbar_el1`), which we'll see more about later.
- All examples this afternoon assume we will be running at exception level 1 (EL1). If you need to run at a different exception level you'll need to modify `entry.s` accordingly.

# Inline assembly

Sometimes we need to use assembly to do things that aren't possible with Rust code. For example, to make an HVC (hypervisor call) to tell the firmware to power off the system:

```

1  #![no_main]
2  #![no_std]
3
4  use core::arch::asm;
5  use core::panic::PanicInfo;
6
7  mod exceptions;
8
9  const PSCI_SYSTEM_OFF: u32 = 0x84000008;
10
11 // SAFETY: There is no other global function of this name.
12 #[unsafe(no_mangle)]
13 extern "C" fn main(_x0: u64, _x1: u64, _x2: u64, _x3: u64) {
14     // SAFETY: this only uses the declared registers and doesn't do anything
15     // with memory.
16     unsafe {
17         asm!("hvc #0",
18             inout("w0") PSCI_SYSTEM_OFF => _,
19             inout("w1") 0 => _,
20             inout("w2") 0 => _,
21             inout("w3") 0 => _,
22             inout("w4") 0 => _,
23             inout("w5") 0 => _,
24             inout("w6") 0 => _,
25             inout("w7") 0 => _,
26             options(nomem, nostack)
27         );
28     }
29
30     loop {}
31 }

```

(If you actually want to do this, use the [smccc](#) crate which has wrappers for all these functions.)

## ▼ Speaker Notes

- PSCI is the Arm Power State Coordination Interface, a standard set of functions to manage system and CPU power states, among other things. It is implemented by EL3 firmware and hypervisors on many systems.
- The `0 => _` syntax means initialise the register to 0 before running the inline assembly code, and ignore its contents afterwards. We need to use `inout` rather than `in`

because the call could potentially clobber the contents of the registers.

- This `main` function needs to be `#[unsafe(no_mangle)]` and `extern "C"` because it is called from our entry point in `entry.S`.
  - Just `#[no_mangle]` would be sufficient but [RFC3325](#) uses this notation to draw reviewer attention to attributes which might cause undefined behavior if used incorrectly.
- `_x0 - _x3` are the values of registers `x0 - x3`, which are conventionally used by the bootloader to pass things like a pointer to the device tree. According to the standard aarch64 calling convention (which is what `extern "C"` specifies to use), registers `x0 - x7` are used for the first 8 arguments passed to a function, so `entry.S` doesn't need to do anything special except make sure it doesn't change these registers.
- Run the example in QEMU with `make qemu_psci` under `src/bare-metal/aps/examples`.

# Volatile memory access for MMIO

- Use `pointer::read_volatile` and `pointer::write_volatile`.
- Never hold a reference to a location being accessed with these methods. Rust may read from (or write to, for `&mut`) a reference at any time.
- Use `&raw` to get fields of structs without creating an intermediate reference.

```
1 |const SOME_DEVICE_REGISTER: *mut u64 = 0x800_0000 as _;  
2 |// SAFETY: Some device is mapped at this address.  
3 |unsafe {  
4 |     SOME_DEVICE_REGISTER.write_volatile(0xff);  
5 |     SOME_DEVICE_REGISTER.write_volatile(0x80);  
6 |     assert_eq!(SOME_DEVICE_REGISTER.read_volatile(), 0xaa);  
7 | }
```

## ▼ Speaker Notes

- Volatile access: read or write operations may have side-effects, so prevent the compiler or hardware from reordering, duplicating or eliding them.
  - Usually if you write and then read, e.g. via a mutable reference, the compiler may assume that the value read is the same as the value just written, and not bother actually reading memory.
- Some existing crates for volatile access to hardware do hold references, but this is unsound. Whenever a reference exist, the compiler may choose to dereference it.
- Use `&raw` to get struct field pointers from a pointer to the struct.
- For compatibility with old versions of Rust you can use the `addr_of!` macro instead.

# Let's write a UART driver

The QEMU 'virt' machine has a [PL011](#) UART, so let's write a driver for that.

```

1  const FLAG_REGISTER_OFFSET: usize = 0x18;
2  const FR_BUSY: u8 = 1 << 3;
3  const FR_TXFF: u8 = 1 << 5;
4
5  /// Minimal driver for a PL011 UART.
6  #[derive(Debug)]
7  pub struct Uart {
8      base_address: *mut u8,
9  }
10
11 impl Uart {
12     /// Constructs a new instance of the UART driver for a PL011 device at the
13     /// given base address.
14     ///
15     /// # Safety
16     ///
17     /// The given base address must point to the 8 MMIO control registers of a
18     /// PL011 device, which must be mapped into the address space of the processor
19     /// as device memory and not have any other aliases.
20     pub unsafe fn new(base_address: *mut u8) -> Self {
21         Self { base_address }
22     }
23
24     /// Writes a single byte to the UART.
25     pub fn write_byte(&self, byte: u8) {
26         // Wait until there is room in the TX buffer.
27         while self.read_flag_register() & FR_TXFF != 0 {}
28
29         // SAFETY: We know that the base address points to the control
30         // registers of a PL011 device which is appropriately mapped.
31         unsafe {
32             // Write to the TX buffer.
33             self.base_address.write_volatile(byte);
34         }
35
36         // Wait until the UART is no longer busy.
37         while self.read_flag_register() & FR_BUSY != 0 {}
38     }
39
40     fn read_flag_register(&self) -> u8 {
41         // SAFETY: We know that the base address points to the control
42         // registers of a PL011 device which is appropriately mapped.
43         unsafe { self.base_address.add(FLAG_REGISTER_OFFSET).read_volatile() }
44     }
45 }

```

### ▼ *Speaker Notes*

- Note that `Uart::new` is unsafe while the other methods are safe. This is because as long as the caller of `Uart::new` guarantees that its safety requirements are met (i.e. that there is only ever one instance of the driver for a given UART, and nothing else aliasing its address space), then it is always safe to call `write_byte` later because we can assume the necessary preconditions.
- We could have done it the other way around (making `new` safe but `write_byte` unsafe), but that would be much less convenient to use as every place that calls `write_byte` would need to reason about the safety
- This is a common pattern for writing safe wrappers of unsafe code: moving the burden of proof for soundness from a large number of places to a smaller number of places.

# More traits

We derived the `Debug` trait. It would be useful to implement a few more traits too.

```
1 use core::fmt::{self, Write};
2
3 impl Write for Uart {
4     fn write_str(&mut self, s: &str) -> fmt::Result {
5         for c in s.as_bytes() {
6             self.write_byte(*c);
7         }
8         Ok(())
9     }
10 }
11
12 // SAFETY: `Uart` just contains a pointer to device memory, which can be
13 // accessed from any context.
14 unsafe impl Send for Uart {}
```

## ▼ Speaker Notes

- Implementing `Write` lets us use the `write!` and `writeln!` macros with our `Uart` type.
- `Send` is an auto-trait, but not implemented automatically because it is not implemented for pointers.

# Using it

Let's write a small program using our driver to write to the serial console.

```

1  #![no_main]
2  #![no_std]
3
4  mod exceptions;
5  mod pl011_minimal;
6
7  use crate::pl011_minimal::Uart;
8  use core::fmt::Write;
9  use core::panic::PanicInfo;
10 use log::error;
11 use smccc::psci::system_off;
12 use smccc::Hvc;
13
14 /// Base address of the primary PL011 UART.
15 const PL011_BASE_ADDRESS: *mut u8 = 0x900_0000 as _;
16
17 // SAFETY: There is no other global function of this name.
18 #[unsafe(no_mangle)]
19 extern "C" fn main(x0: u64, x1: u64, x2: u64, x3: u64) {
20     // SAFETY: `PL011_BASE_ADDRESS` is the base address of a PL011 device, and
21     // nothing else accesses that address range.
22     let mut uart = unsafe { Uart::new(PL011_BASE_ADDRESS) };
23
24     writeln!(uart, "main({x0:#x}, {x1:#x}, {x2:#x}, {x3:#x})").unwrap();
25
26     system_off::<Hvc>().unwrap();
27 }

```

## ▼ Speaker Notes

- As in the [inline assembly](#) example, this `main` function is called from our entry point code in `entry.s`. See the speaker notes there for details.
- Run the example in QEMU with `make qemu_minimal` under `src/bare-metal/aps/examples`.



# A better UART driver

The PL011 actually has [a bunch more registers](#), and adding offsets to construct pointers to access them is error-prone and hard to read. Plus, some of them are bit fields which would be nice to access in a structured way.

Offset	Register name	Width
0x00	DR	12
0x04	RSR	4
0x18	FR	9
0x20	ILPR	8
0x24	IBRD	16
0x28	FBRD	6
0x2c	LCR_H	8
0x30	CR	16
0x34	IFLS	6
0x38	IMSC	11
0x3c	RIS	11
0x40	MIS	11
0x44	ICR	11
0x48	DMACR	3

## ▼ *Speaker Notes*

- There are also some ID registers which have been omitted for brevity.

# Bitflags

The `bitflags` crate is useful for working with bitflags.

```
1 use bitflags::bitflags;
2
3 bitflags! {
4     /// Flags from the UART flag register.
5     #[repr(transparent)]
6     #[derive(Copy, Clone, Debug, Eq, PartialEq)]
7     struct Flags: u16 {
8         /// Clear to send.
9         const CTS = 1 << 0;
10        /// Data set ready.
11        const DSR = 1 << 1;
12        /// Data carrier detect.
13        const DCD = 1 << 2;
14        /// UART busy transmitting data.
15        const BUSY = 1 << 3;
16        /// Receive FIFO is empty.
17        const RXFE = 1 << 4;
18        /// Transmit FIFO is full.
19        const TXFF = 1 << 5;
20        /// Receive FIFO is full.
21        const RXFF = 1 << 6;
22        /// Transmit FIFO is empty.
23        const TXFE = 1 << 7;
24        /// Ring indicator.
25        const RI = 1 << 8;
26    }
27 }
```

## ▼ Speaker Notes

- The `bitflags!` macro creates a newtype something like `Flags(u16)`, along with a bunch of method implementations to get and set flags.

# Multiple registers

We can use a struct to represent the memory layout of the UART's registers.

```
1  #[repr(C, align(4))]
2  struct Registers {
3      dr: u16,
4      _reserved0: [u8; 2],
5      rsr: ReceiveStatus,
6      _reserved1: [u8; 19],
7      fr: Flags,
8      _reserved2: [u8; 6],
9      ilpr: u8,
10     _reserved3: [u8; 3],
11     ibrd: u16,
12     _reserved4: [u8; 2],
13     fbrd: u8,
14     _reserved5: [u8; 3],
15     lcr_h: u8,
16     _reserved6: [u8; 3],
17     cr: u16,
18     _reserved7: [u8; 3],
19     ifls: u8,
20     _reserved8: [u8; 3],
21     imsc: u16,
22     _reserved9: [u8; 2],
23     ris: u16,
24     _reserved10: [u8; 2],
25     mis: u16,
26     _reserved11: [u8; 2],
27     icr: u16,
28     _reserved12: [u8; 2],
29     dmacr: u8,
30     _reserved13: [u8; 3],
31 }
```

## ▼ Speaker Notes

- `#[repr(C)]` tells the compiler to lay the struct fields out in order, following the same rules as C. This is necessary for our struct to have a predictable layout, as default Rust representation allows the compiler to (among other things) reorder fields however it sees fit.

# Driver

Now let's use the new `Registers` struct in our driver.

```

1  /// Driver for a PL011 UART.
2  #[derive(Debug)]
3  pub struct Uart {
4      registers: *mut Registers,
5  }
6
7  impl Uart {
8      /// Constructs a new instance of the UART driver for a PL011 device at the
9      /// given base address.
10     ///
11     /// # Safety
12     ///
13     /// The given base address must point to the 8 MMIO control registers of a
14     /// PL011 device, which must be mapped into the address space of the processor
15     /// as device memory and not have any other aliases.
16     pub unsafe fn new(base_address: *mut u32) -> Self {
17         Self { registers: base_address as *mut Registers }
18     }
19
20     /// Writes a single byte to the UART.
21     pub fn write_byte(&self, byte: u8) {
22         // Wait until there is room in the TX buffer.
23         while self.read_flag_register().contains(Flags::TXFF) {}
24
25         // SAFETY: We know that self.registers points to the control register
26         // of a PL011 device which is appropriately mapped.
27         unsafe {
28             // Write to the TX buffer.
29             (&raw mut (*self.registers).dr).write_volatile(byte.into());
30         }
31
32         // Wait until the UART is no longer busy.
33         while self.read_flag_register().contains(Flags::BUSY) {}
34     }
35
36     /// Reads and returns a pending byte, or `None` if nothing has been
37     /// received.
38     pub fn read_byte(&self) -> Option<u8> {
39         if self.read_flag_register().contains(Flags::RXFE) {
40             None
41         } else {
42             // SAFETY: We know that self.registers points to the control
43             // registers of a PL011 device which is appropriately mapped.
44             let data = unsafe { (&raw const (*self.registers).dr).read_volatile() };
45             // TODO: Check for error conditions in bits 8-11.
46             Some(data as u8)
47         }
48     }
49
50     fn read_flag_register(&self) -> Flags {
51         // SAFETY: We know that self.registers points to the control register
52         // of a PL011 device which is appropriately mapped.
53         unsafe { (&raw const (*self.registers).fr).read_volatile() }
54     }
55 }

```

### ▼ *Speaker Notes*

- Note the use of `&raw const` / `&raw mut` to get pointers to individual fields without creating an intermediate reference, which would be unsound.

# Using it

Let's write a small program using our driver to write to the serial console, and echo incoming bytes.

```

1  #![no_main]
2  #![no_std]
3
4  mod exceptions;
5  mod pl011;
6
7  use crate::pl011::Uart;
8  use core::fmt::Write;
9  use core::panic::PanicInfo;
10 use log::error;
11 use smccc::psci::system_off;
12 use smccc::Hvc;
13
14 /// Base address of the primary PL011 UART.
15 const PL011_BASE_ADDRESS: *mut u32 = 0x900_0000 as _;
16
17 // SAFETY: There is no other global function of this name.
18 #[unsafe(no_mangle)]
19 extern "C" fn main(x0: u64, x1: u64, x2: u64, x3: u64) {
20     // SAFETY: `PL011_BASE_ADDRESS` is the base address of a PL011 device, and
21     // nothing else accesses that address range.
22     let mut uart = unsafe { Uart::new(PL011_BASE_ADDRESS) };
23
24     writeln!(uart, "main({x0:#x}, {x1:#x}, {x2:#x}, {x3:#x})").unwrap();
25
26     loop {
27         if let Some(byte) = uart.read_byte() {
28             uart.write_byte(byte);
29             match byte {
30                 b'\r' => uart.write_byte(b'\n'),
31                 b'q' => break,
32                 _ => continue,
33             }
34         }
35     }
36
37     writeln!(uart, "\n\nBye!").unwrap();
38     system_off::<Hvc>().unwrap();
39 }

```

## ▼ Speaker Notes

- Run the example in QEMU with `make qemu` under `src/bare-metal/aps/examples`.

# Logging

It would be nice to be able to use the logging macros from the `log` crate. We can do this by implementing the `Log` trait.

```

1 use crate::pl011::Uart;
2 use core::fmt::Write;
3 use log::{LevelFilter, Log, Metadata, Record, SetLoggerError};
4 use spin::mutex::SpinMutex;
5
6 static LOGGER: Logger = Logger { uart: SpinMutex::new(None) };
7
8 struct Logger {
9     uart: SpinMutex<Option<Uart>>,
10 }
11
12 impl Log for Logger {
13     fn enabled(&self, _metadata: &Metadata) -> bool {
14         true
15     }
16
17     fn log(&self, record: &Record) {
18         writeln!(
19             self.uart.lock().as_mut().unwrap(),
20             "[{}] {}",
21             record.level(),
22             record.args()
23         )
24         .unwrap();
25     }
26
27     fn flush(&self) {}
28 }
29
30 /// Initialises UART logger.
31 pub fn init(uart: Uart, max_level: LevelFilter) -> Result<(), SetLoggerError>
32     LOGGER.uart.lock().replace(uart);
33
34     log::set_logger(&LOGGER)?;
35     log::set_max_level(max_level);
36     Ok(())
37 }

```

## ▼ Speaker Notes

- The first `unwrap` in `log` will succeed because we initialise `LOGGER` before calling `set_logger`. The second will succeed because `Uart::write_str` always returns `ok`.



# Using it

We need to initialise the logger before we use it.

```

1  #![no_main]
2  #![no_std]
3
4  mod exceptions;
5  mod logger;
6  mod pl011;
7
8  use crate::pl011::Uart;
9  use core::panic::PanicInfo;
10 use log::{error, info, LevelFilter};
11 use smccc::psci::system_off;
12 use smccc::Hvc;
13
14 /// Base address of the primary PL011 UART.
15 const PL011_BASE_ADDRESS: *mut u32 = 0x900_0000 as _;
16
17 // SAFETY: There is no other global function of this name.
18 #[unsafe(no_mangle)]
19 extern "C" fn main(x0: u64, x1: u64, x2: u64, x3: u64) {
20     // SAFETY: `PL011_BASE_ADDRESS` is the base address of a PL011 device, and
21     // nothing else accesses that address range.
22     let uart = unsafe { Uart::new(PL011_BASE_ADDRESS) };
23     logger::init(uart, LevelFilter::Trace).unwrap();
24
25     info!("main({x0:#x}, {x1:#x}, {x2:#x}, {x3:#x})");
26
27     assert_eq!(x1, 42);
28
29     system_off::<Hvc>().unwrap();
30 }
31
32 #[panic_handler]
33 fn panic(info: &PanicInfo) -> ! {
34     error!("{info}");
35     system_off::<Hvc>().unwrap();
36     loop {}
37 }

```

## ▼ Speaker Notes

- Note that our panic handler can now log details of panics.
- Run the example in QEMU with `make qemu_logger` under `src/bare-metal/aps/examples`.

# Exceptions

AArch64 defines an exception vector table with 16 entries, for 4 types of exceptions (synchronous, IRQ, FIQ, SError) from 4 states (current EL with SP0, current EL with SPx, lower EL using AArch64, lower EL using AArch32). We implement this in assembly to save volatile registers to the stack before calling into Rust code:

```

1 use log::error;
2 use smccc::psci::system_off;
3 use smccc::Hvc;
4
5 // SAFETY: There is no other global function of this name.
6 #[unsafe(no_mangle)]
7 extern "C" fn sync_exception_current(_elr: u64, _spsr: u64) {
8     error!("sync_exception_current");
9     system_off::<Hvc>().unwrap();
10 }
11
12 // SAFETY: There is no other global function of this name.
13 #[unsafe(no_mangle)]
14 extern "C" fn irq_current(_elr: u64, _spsr: u64) {
15     error!("irq_current");
16     system_off::<Hvc>().unwrap();
17 }
18
19 // SAFETY: There is no other global function of this name.
20 #[unsafe(no_mangle)]
21 extern "C" fn fiq_current(_elr: u64, _spsr: u64) {
22     error!("fiq_current");
23     system_off::<Hvc>().unwrap();
24 }
25
26 // SAFETY: There is no other global function of this name.
27 #[unsafe(no_mangle)]
28 extern "C" fn serr_current(_elr: u64, _spsr: u64) {
29     error!("serr_current");
30     system_off::<Hvc>().unwrap();
31 }
32
33 // SAFETY: There is no other global function of this name.
34 #[unsafe(no_mangle)]
35 extern "C" fn sync_lower(_elr: u64, _spsr: u64) {
36     error!("sync_lower");
37     system_off::<Hvc>().unwrap();
38 }
39
40 // SAFETY: There is no other global function of this name.
41 #[unsafe(no_mangle)]
42 extern "C" fn irq_lower(_elr: u64, _spsr: u64) {
43     error!("irq_lower");
44     system_off::<Hvc>().unwrap();
45 }
46
47 // SAFETY: There is no other global function of this name.
48 #[unsafe(no_mangle)]
49 extern "C" fn fiq_lower(_elr: u64, _spsr: u64) {
50     error!("fiq_lower");
51     system_off::<Hvc>().unwrap();
52 }
53
54 // SAFETY: There is no other global function of this name.
55 #[unsafe(no_mangle)]

```

```
55     #[no_mangle]
56     extern "C" fn serr_lower(_elr: u64, _spsr: u64) {
57         error!("serr_lower");
58         system_off::<Hvc>().unwrap();
59     }
```

### ▼ *Speaker Notes*

- EL is exception level; all our examples this afternoon run in EL1.
- For simplicity we aren't distinguishing between SP0 and SPx for the current EL exceptions, or between AArch32 and AArch64 for the lower EL exceptions.
- For this example we just log the exception and power down, as we don't expect any of them to actually happen.
- We can think of exception handlers and our main execution context more or less like different threads. `Send` and `Sync` will control what we can share between them, just like with threads. For example, if we want to share some value between exception handlers and the rest of the program, and it's `Send` but not `Sync`, then we'll need to wrap it in something like a `Mutex` and put it in a static.

# Other projects

- [oreboot](#)
  - “coreboot without the C”.
  - Supports x86, aarch64 and RISC-V.
  - Relies on LinuxBoot rather than having many drivers itself.
- [Rust RaspberryPi OS tutorial](#)
  - Initialisation, UART driver, simple bootloader, JTAG, exception levels, exception handling, page tables.
  - Some dodginess around cache maintenance and initialisation in Rust, not necessarily a good example to copy for production code.
- [cargo-call-stack](#)
  - Static analysis to determine maximum stack usage.

## ▼ *Speaker Notes*

- The RaspberryPi OS tutorial runs Rust code before the MMU and caches are enabled. This will read and write memory (e.g. the stack). However, this has the problems mentioned at the beginning of this session regarding unaligned access and cache coherency.

# Useful crates

We'll look at a few crates which solve some common problems in bare-metal programming.

# zerocopy

The `zerocopy` crate (from Fuchsia) provides traits and macros for safely converting between byte sequences and other types.

```

1 use zerocopy::{Immutable, IntoBytes};
2
3 #[repr(u32)]
4 #[derive(Debug, Default, Immutable, IntoBytes)]
5 enum RequestType {
6     #[default]
7     In = 0,
8     Out = 1,
9     Flush = 4,
10 }
11
12 #[repr(C)]
13 #[derive(Debug, Default, Immutable, IntoBytes)]
14 struct VirtioBlockRequest {
15     request_type: RequestType,
16     reserved: u32,
17     sector: u64,
18 }
19
20 fn main() {
21     let request = VirtioBlockRequest {
22         request_type: RequestType::Flush,
23         sector: 42,
24         ..Default::default()
25     };
26
27     assert_eq!(
28         request.as_bytes(),
29         &[4, 0, 0, 0, 0, 0, 0, 0, 0, 42, 0, 0, 0, 0, 0, 0, 0]
30     );
31 }

```

This is not suitable for MMIO (as it doesn't use volatile reads and writes), but can be useful for working with structures shared with hardware e.g. by DMA, or sent over some external interface.

## ▼ Speaker Notes

- `FromBytes` can be implemented for types for which any byte pattern is valid, and so can safely be converted from an untrusted sequence of bytes.
- Attempting to derive `FromBytes` for these types would fail, because `RequestType` doesn't use all possible `u32` values as discriminants, so not all byte patterns are valid.

- `zerocopy::byteorder` has types for byte-order aware numeric primitives.
- Run the example with `cargo run` under `src/bare-metal/useful-crates/zerocopy-example/`. (It won't run in the Playground because of the crate dependency.)



# aarch64-paging

The `aarch64-paging` crate lets you create page tables according to the AArch64 Virtual Memory System Architecture.

```
1 use aarch64_paging::{
2     idmap::IdMap,
3     paging::{Attributes, MemoryRegion},
4 };
5
6 const ASID: usize = 1;
7 const ROOT_LEVEL: usize = 1;
8
9 // Create a new page table with identity mapping.
10 let mut idmap = IdMap::new(ASID, ROOT_LEVEL);
11 // Map a 2 MiB region of memory as read-only.
12 idmap.map_range(
13     &MemoryRegion::new(0x80200000, 0x80400000),
14     Attributes::NORMAL | Attributes::NON_GLOBAL | Attributes::READ_ONLY,
15 ).unwrap();
16 // Set `TTBR0_EL1` to activate the page table.
17 idmap.activate();
```

## ▼ Speaker Notes

- For now it only supports EL1, but support for other exception levels should be straightforward to add.
- This is used in Android for the [Protected VM Firmware](#).
- There's no easy way to run this example, as it needs to run on real hardware or under QEMU.

# buddy\_system\_allocator

`buddy_system_allocator` is a crate implementing a basic buddy system allocator. It can be used both to implement `GlobalAlloc` (using `LockedHeap`) so you can use the standard `alloc` crate (as we saw [before](#)), or for allocating other address space (using `FrameAllocator`). For example, we might want to allocate MMIO space for PCI BARs:

```
1 use buddy_system_allocator::FrameAllocator;
2 use core::alloc::Layout;
3
4 fn main() {
5     let mut allocator = FrameAllocator::<32>::new();
6     allocator.add_frame(0x200_0000, 0x400_0000);
7
8     let layout = Layout::from_size_align(0x100, 0x100).unwrap();
9     let bar = allocator
10         .alloc_aligned(layout)
11         .expect("Failed to allocate 0x100 byte MMIO region");
12     println!("Allocated 0x100 byte MMIO region at {:#x}", bar);
13 }
```

## ▼ *Speaker Notes*

- PCI BARs always have alignment equal to their size.
- Run the example with `cargo run` under `src/bare-metal/useful-crates/allocator-example/`. (It won't run in the Playground because of the crate dependency.)

# tinyvec

Sometimes you want something which can be resized like a `Vec`, but without heap allocation. `tinyvec` provides this: a vector backed by an array or slice, which could be statically allocated or on the stack, which keeps track of how many elements are used and panics if you try to use more than are allocated.

```
1 use tinyvec::{array_vec, ArrayVec};
2
3 fn main() {
4     let mut numbers: ArrayVec<[u32; 5]> = array_vec!(42, 66);
5     println!("{numbers:?}");
6     numbers.push(7);
7     println!("{numbers:?}");
8     numbers.remove(1);
9     println!("{numbers:?}");
10 }
```

## ▼ *Speaker Notes*

- `tinyvec` requires that the element type implement `Default` for initialisation.
- The Rust Playground includes `tinyvec`, so this example will run fine inline.

# spin

`std::sync::Mutex` and the other synchronisation primitives from `std::sync` are not available in `core` or `alloc`. How can we manage synchronisation or interior mutability, such as for sharing state between different CPUs?

The `spin` crate provides spinlock-based equivalents of many of these primitives.

```
1 use spin::mutex::SpinMutex;
2
3 static COUNTER: SpinMutex<u32> = SpinMutex::new(0);
4
5 fn main() {
6     dbg!(COUNTER.lock());
7     *COUNTER.lock() += 2;
8     dbg!(COUNTER.lock());
9 }
```

## ▼ Speaker Notes

- Be careful to avoid deadlock if you take locks in interrupt handlers.
- `spin` also has a ticket lock mutex implementation; equivalents of `RwLock`, `Barrier` and `Once` from `std::sync`; and `Lazy` for lazy initialisation.
- The `once_cell` crate also has some useful types for late initialisation with a slightly different approach to `spin::once::Once`.
- The Rust Playground includes `spin`, so this example will run fine inline.

# Bare-Metal on Android

To build a bare-metal Rust binary in AOSP, you need to use a `rust_ffi_static` Soong rule to build your Rust code, then a `cc_binary` with a linker script to produce the binary itself, and then a `raw_binary` to convert the ELF to a raw binary ready to be run.

```
rust_ffi_static {
    name: "libvmbase_example",
    defaults: ["vmbase_ffi_defaults"],
    crate_name: "vmbase_example",
    srcs: ["src/main.rs"],
    rustlibs: [
        "libvmbase",
    ],
}

cc_binary {
    name: "vmbase_example",
    defaults: ["vmbase_elf_defaults"],
    srcs: [
        "idmap.S",
    ],
    static_libs: [
        "libvmbase_example",
    ],
    linker_scripts: [
        "image.ld",
        ":vmbase_sections",
    ],
}

raw_binary {
    name: "vmbase_example_bin",
    stem: "vmbase_example.bin",
    src: ":vmbase_example",
    enabled: false,
    target: {
        android_arm64: {
            enabled: true,
        },
    },
}
```

# vmbase

For VMs running under `crosvm` on `aarch64`, the `vmbase` library provides a linker script and useful defaults for the build rules, along with an entry point, UART console logging and more.

```
#![no_main]
#![no_std]

use vmbase::{main, println};

main!(main);

pub fn main(arg0: u64, arg1: u64, arg2: u64, arg3: u64) {
    println!("Hello world");
}
```

## ▼ *Speaker Notes*

- The `main!` macro marks your main function, to be called from the `vmbase` entry point.
- The `vmbase` entry point handles console initialisation, and issues a `PSCI_SYSTEM_OFF` to shutdown the VM if your main function returns.

# Exercises

We will write a driver for the PL031 real-time clock device.

## ▼ *Speaker Notes*

After looking at the exercises, you can look at the [solutions](#) provided.

# RTC driver

The QEMU aarch64 virt machine has a [PL031](#) real-time clock at 0x9010000. For this exercise, you should write a driver for it.

1. Use it to print the current time to the serial console. You can use the [chrono](#) crate for date/time formatting.
2. Use the match register and raw interrupt status to busy-wait until a given time, e.g. 3 seconds in the future. (Call `core::hint::spin_loop` inside the loop.)
3. *Extension if you have time:* Enable and handle the interrupt generated by the RTC match. You can use the driver provided in the [arm-gic](#) crate to configure the Arm Generic Interrupt Controller.
  - Use the RTC interrupt, which is wired to the GIC as `IntId::spi(2)`.
  - Once the interrupt is enabled, you can put the core to sleep via `arm_gic::wfi()`, which will cause the core to sleep until it receives an interrupt.

Download the [exercise template](#) and look in the `rtc` directory for the following files.

*src/main.rs:*



```

#![no_main]
#![no_std]

mod exceptions;
mod logger;
mod pl011;

use crate::pl011::Uart;
use arm_gic::gicv3::GicV3;
use core::panic::PanicInfo;
use log::{error, info, trace, LevelFilter};
use smccc::psci::system_off;
use smccc::Hvc;

/// Base addresses of the GICv3.
const GICD_BASE_ADDRESS: *mut u64 = 0x800_0000 as _;
const GICR_BASE_ADDRESS: *mut u64 = 0x80A_0000 as _;

/// Base address of the primary PL011 UART.
const PL011_BASE_ADDRESS: *mut u32 = 0x900_0000 as _;

// SAFETY: There is no other global function of this name.
#[unsafe(no_mangle)]
extern "C" fn main(x0: u64, x1: u64, x2: u64, x3: u64) {
    // SAFETY: `PL011_BASE_ADDRESS` is the base address of a PL011 device, and
    // nothing else accesses that address range.
    let uart = unsafe { Uart::new(PL011_BASE_ADDRESS) };
    logger::init(uart, LevelFilter::Trace).unwrap();

    info!("main({:#x}, {:#x}, {:#x}, {:#x})", x0, x1, x2, x3);

    // SAFETY: `GICD_BASE_ADDRESS` and `GICR_BASE_ADDRESS` are the base
    // addresses of a GICv3 distributor and redistributor respectively, and
    // nothing else accesses those address ranges.
    let mut gic =
        unsafe { GicV3::new(GICD_BASE_ADDRESS, GICR_BASE_ADDRESS, 1, 0x20000) };
    gic.setup(0);

    // TODO: Create instance of RTC driver and print current time.

    // TODO: Wait for 3 seconds.

    system_off::<Hvc>().unwrap();
}

#[panic_handler]
fn panic(info: &PanicInfo) -> ! {
    error!("{info}");
    system_off::<Hvc>().unwrap();
    loop {}
}

```

*src/exceptions.rs* (you should only need to change this for the 3rd part of the exercise):

```

// Copyright 2023 Google LLC
//
// Licensed under the Apache License, Version 2.0 (the "License");
// you may not use this file except in compliance with the License.
// You may obtain a copy of the License at
//
//      http://www.apache.org/licenses/LICENSE-2.0
//
// Unless required by applicable law or agreed to in writing, software
// distributed under the License is distributed on an "AS IS" BASIS,
// WITHOUT WARRANTIES OR CONDITIONS OF ANY KIND, either express or implied.
// See the License for the specific language governing permissions and
// limitations under the License.

use arm_gic::gicv3::GicV3;
use log::{error, info, trace};
use smccc::psci::system_off;
use smccc::Hvc;

// SAFETY: There is no other global function of this name.
#[unsafe(no_mangle)]
extern "C" fn sync_exception_current(_elr: u64, _spsr: u64) {
    error!("sync_exception_current");
    system_off::<<Hvc>().unwrap();
}

// SAFETY: There is no other global function of this name.
#[unsafe(no_mangle)]
extern "C" fn irq_current(_elr: u64, _spsr: u64) {
    trace!("irq_current");
    let intid =
        GicV3::get_and_acknowledge_interrupt().expect("No pending interrupt");
    info!("IRQ {intid:?}");
}

// SAFETY: There is no other global function of this name.
#[unsafe(no_mangle)]
extern "C" fn fiq_current(_elr: u64, _spsr: u64) {
    error!("fiq_current");
    system_off::<<Hvc>().unwrap();
}

// SAFETY: There is no other global function of this name.
#[unsafe(no_mangle)]
extern "C" fn serr_current(_elr: u64, _spsr: u64) {
    error!("serr_current");
    system_off::<<Hvc>().unwrap();
}

// SAFETY: There is no other global function of this name.
#[unsafe(no_mangle)]
extern "C" fn sync_lower(_elr: u64, _spsr: u64) {
    error!("sync_lower");
    system_off::<<Hvc>().unwrap();
}

```

```
}

// SAFETY: There is no other global function of this name.
#[unsafe(no_mangle)]
extern "C" fn irq_lower(_elr: u64, _spsr: u64) {
    error!("irq_lower");
    system_off::().unwrap();
}

// SAFETY: There is no other global function of this name.
#[unsafe(no_mangle)]
extern "C" fn fiq_lower(_elr: u64, _spsr: u64) {
    error!("fiq_lower");
    system_off::().unwrap();
}

// SAFETY: There is no other global function of this name.
#[unsafe(no_mangle)]
extern "C" fn serr_lower(_elr: u64, _spsr: u64) {
    error!("serr_lower");
    system_off::().unwrap();
}
```

*src/logger.rs* (you shouldn't need to change this):

```

// Copyright 2023 Google LLC
//
// Licensed under the Apache License, Version 2.0 (the "License");
// you may not use this file except in compliance with the License.
// You may obtain a copy of the License at
//
//      http://www.apache.org/licenses/LICENSE-2.0
//
// Unless required by applicable law or agreed to in writing, software
// distributed under the License is distributed on an "AS IS" BASIS,
// WITHOUT WARRANTIES OR CONDITIONS OF ANY KIND, either express or implied.
// See the License for the specific language governing permissions and
// limitations under the License.

// ANCHOR: main
use crate::pl011::Uart;
use core::fmt::Write;
use log::{LevelFilter, Log, Metadata, Record, SetLoggerError};
use spin::mutex::SpinMutex;

static LOGGER: Logger = Logger { uart: SpinMutex::new(None) };

struct Logger {
    uart: SpinMutex<Option<Uart>>,
}

impl Log for Logger {
    fn enabled(&self, _metadata: &Metadata) -> bool {
        true
    }

    fn log(&self, record: &Record) {
        writeln!(
            self.uart.lock().as_mut().unwrap(),
            "[{}] {}",
            record.level(),
            record.args()
        )
        .unwrap();
    }

    fn flush(&self) {}
}

/// Initialises UART logger.
pub fn init(uart: Uart, max_level: LevelFilter) -> Result<(), SetLoggerError> {
    LOGGER.uart.lock().replace(uart);

    log::set_logger(&LOGGER)?;
    log::set_max_level(max_level);
    Ok(())
}

```

*src/pl011.rs* (you shouldn't need to change this):

```
// Copyright 2023 Google LLC
//
// Licensed under the Apache License, Version 2.0 (the "License");
// you may not use this file except in compliance with the License.
// You may obtain a copy of the License at
//
//      http://www.apache.org/licenses/LICENSE-2.0
//
// Unless required by applicable law or agreed to in writing, software
// distributed under the License is distributed on an "AS IS" BASIS,
// WITHOUT WARRANTIES OR CONDITIONS OF ANY KIND, either express or implied.
// See the License for the specific language governing permissions and
// limitations under the License.
```

```
#![allow(unused)]
```

```
use core::fmt::{self, Write};
```

```
// ANCHOR: Flags
```

```
use bitflags::bitflags;
```

```
bitflags! {
    /// Flags from the UART flag register.
    #[repr(transparent)]
    #[derive(Copy, Clone, Debug, Eq, PartialEq)]
    struct Flags: u16 {
        /// Clear to send.
        const CTS = 1 << 0;
        /// Data set ready.
        const DSR = 1 << 1;
        /// Data carrier detect.
        const DCD = 1 << 2;
        /// UART busy transmitting data.
        const BUSY = 1 << 3;
        /// Receive FIFO is empty.
        const RXFE = 1 << 4;
        /// Transmit FIFO is full.
        const TXFF = 1 << 5;
        /// Receive FIFO is full.
        const RXFF = 1 << 6;
        /// Transmit FIFO is empty.
        const TXFE = 1 << 7;
        /// Ring indicator.
        const RI = 1 << 8;
    }
}
// ANCHOR_END: Flags
```

```
bitflags! {
    /// Flags from the UART Receive Status Register / Error Clear Register.
    #[repr(transparent)]
    #[derive(Copy, Clone, Debug, Eq, PartialEq)]
    struct ReceiveStatus: u16 {
        /// Framing error.
```

```

    const FE = 1 << 0;
    /// Parity error.
    const PE = 1 << 1;
    /// Break error.
    const BE = 1 << 2;
    /// Overrun error.
    const OE = 1 << 3;
}
}

// ANCHOR: Registers
#[repr(C, align(4))]
struct Registers {
    dr: u16,
    _reserved0: [u8; 2],
    rsr: ReceiveStatus,
    _reserved1: [u8; 19],
    fr: Flags,
    _reserved2: [u8; 6],
    ilpr: u8,
    _reserved3: [u8; 3],
    ibrd: u16,
    _reserved4: [u8; 2],
    fbrd: u8,
    _reserved5: [u8; 3],
    lcr_h: u8,
    _reserved6: [u8; 3],
    cr: u16,
    _reserved7: [u8; 3],
    ifls: u8,
    _reserved8: [u8; 3],
    imsc: u16,
    _reserved9: [u8; 2],
    ris: u16,
    _reserved10: [u8; 2],
    mis: u16,
    _reserved11: [u8; 2],
    icr: u16,
    _reserved12: [u8; 2],
    dmacr: u8,
    _reserved13: [u8; 3],
}

// ANCHOR_END: Registers

// ANCHOR: Uart
/// Driver for a PL011 UART.
#[derive(Debug)]
pub struct Uart {
    registers: *mut Registers,
}

impl Uart {
    /// Constructs a new instance of the UART driver for a PL011 device at the
    /// given base address.

```

```

///
/// # Safety
///
/// The given base address must point to the MMIO control registers of a
/// PL011 device, which must be mapped into the address space of the process
/// as device memory and not have any other aliases.
pub unsafe fn new(base_address: *mut u32) -> Self {
    Self { registers: base_address as *mut Registers }
}

/// Writes a single byte to the UART.
pub fn write_byte(&self, byte: u8) {
    // Wait until there is room in the TX buffer.
    while self.read_flag_register().contains(Flags::TXFF) {}

    // SAFETY: We know that self.registers points to the control registers
    // of a PL011 device which is appropriately mapped.
    unsafe {
        // Write to the TX buffer.
        (&raw mut (*self.registers).dr).write_volatile(byte.into());
    }

    // Wait until the UART is no longer busy.
    while self.read_flag_register().contains(Flags::BUSY) {}
}

/// Reads and returns a pending byte, or `None` if nothing has been
/// received.
pub fn read_byte(&self) -> Option<u8> {
    if self.read_flag_register().contains(Flags::RXFE) {
        None
    } else {
        // SAFETY: We know that self.registers points to the control
        // registers of a PL011 device which is appropriately mapped.
        let data = unsafe { (&raw const (*self.registers).dr).read_volatile()
};

        // TODO: Check for error conditions in bits 8-11.
        Some(data as u8)
    }
}

fn read_flag_register(&self) -> Flags {
    // SAFETY: We know that self.registers points to the control registers
    // of a PL011 device which is appropriately mapped.
    unsafe { (&raw const (*self.registers).fr).read_volatile() }
}
}
// ANCHOR_END: Uart

impl Write for Uart {
    fn write_str(&mut self, s: &str) -> fmt::Result {
        for c in s.as_bytes() {
            self.write_byte(*c);
        }
}

```



```
        Ok(())  
    }  
}
```

```
// Safe because it just contains a pointer to device memory, which can be  
// accessed from any context.  
unsafe impl Send for Uart {}
```

*Cargo.toml* (you shouldn't need to change this):

```
[workspace]  
  
[package]  
name = "rtc"  
version = "0.1.0"  
edition = "2021"  
publish = false  
  
[dependencies]  
arm-gic = "0.2.2"  
bitflags = "2.9.0"  
chrono = { version = "0.4.40", default-features = false }  
log = "0.4.26"  
smccc = "0.1.1"  
spin = "0.9.8"  
  
[build-dependencies]  
cc = "1.2.16"
```

*build.rs* (you shouldn't need to change this):

```
// Copyright 2023 Google LLC
//
// Licensed under the Apache License, Version 2.0 (the "License");
// you may not use this file except in compliance with the License.
// You may obtain a copy of the License at
//
//      http://www.apache.org/licenses/LICENSE-2.0
//
// Unless required by applicable law or agreed to in writing, software
// distributed under the License is distributed on an "AS IS" BASIS,
// WITHOUT WARRANTIES OR CONDITIONS OF ANY KIND, either express or implied.
// See the License for the specific language governing permissions and
// limitations under the License.

use cc::Build;
use std::env;

fn main() {
    env::set_var("CROSS_COMPILE", "aarch64-none-elf");
    env::set_var("CC", "clang");

    Build::new()
        .file("entry.S")
        .file("exceptions.S")
        .file("idmap.S")
        .compile("empty")
}
```

*entry.S* (you shouldn't need to change this):

```

/*
 * Copyright 2023 Google LLC
 *
 * Licensed under the Apache License, Version 2.0 (the "License");
 * you may not use this file except in compliance with the License.
 * You may obtain a copy of the License at
 *
 *     https://www.apache.org/licenses/LICENSE-2.0
 *
 * Unless required by applicable law or agreed to in writing, software
 * distributed under the License is distributed on an "AS IS" BASIS,
 * WITHOUT WARRANTIES OR CONDITIONS OF ANY KIND, either express or implied.
 * See the License for the specific language governing permissions and
 * limitations under the License.
 */

.macro adr_l, reg:req, sym:req
    adrp \reg, \sym
    add \reg, \reg, :lo12:\sym
.endm

.macro mov_i, reg:req, imm:req
    movz \reg, :abs_g3:\imm
    movk \reg, :abs_g2_nc:\imm
    movk \reg, :abs_g1_nc:\imm
    movk \reg, :abs_g0_nc:\imm
.endm

.set .L_MAIR_DEV_nGnRE, 0x04
.set .L_MAIR_MEM_WBWA, 0xff
.set .Lmairval, .L_MAIR_DEV_nGnRE | (.L_MAIR_MEM_WBWA << 8)

/* 4 KiB granule size for TTBR0_EL1. */
.set .L_TCR_TG0_4KB, 0x0 << 14
/* 4 KiB granule size for TTBR1_EL1. */
.set .L_TCR_TG1_4KB, 0x2 << 30
/* Disable translation table walk for TTBR1_EL1, generating a translation fault
instead. */
.set .L_TCR_EPD1, 0x1 << 23
/* Translation table walks for TTBR0_EL1 are inner sharable. */
.set .L_TCR_SH_INNER, 0x3 << 12
/*
 * Translation table walks for TTBR0_EL1 are outer write-back read-allocate
write-allocate
 * cacheable.
 */
.set .L_TCR_RGN_OWB, 0x1 << 10
/*
 * Translation table walks for TTBR0_EL1 are inner write-back read-allocate
write-allocate
 * cacheable.
 */
.set .L_TCR_RGN_IWB, 0x1 << 8
/* Size offset for TTBR0_EL1 is 2**39 bytes (512 GiB). */

```

```

.set .L_TCR_T0SZ_512, 64 - 39
.set .L_tcrval, .L_TCR_TG0_4KB | .L_TCR_TG1_4KB | .L_TCR_EPD1 | .L_TCR_RGN_OWB
.set .L_tcrval, .L_tcrval | .L_TCR_RGN_IWB | .L_TCR_SH_INNER | .L_TCR_T0SZ_512

/* Stage 1 instruction access cacheability is unaffected. */
.set .L_SCTLR_ELx_I, 0x1 << 12
/* SP alignment fault if SP is not aligned to a 16 byte boundary. */
.set .L_SCTLR_ELx_SA, 0x1 << 3
/* Stage 1 data access cacheability is unaffected. */
.set .L_SCTLR_ELx_C, 0x1 << 2
/* EL0 and EL1 stage 1 MMU enabled. */
.set .L_SCTLR_ELx_M, 0x1 << 0
/* Privileged Access Never is unchanged on taking an exception to EL1. */
.set .L_SCTLR_EL1_SPAN, 0x1 << 23
/* SETEND instruction disabled at EL0 in aarch32 mode. */
.set .L_SCTLR_EL1_SED, 0x1 << 8
/* Various IT instructions are disabled at EL0 in aarch32 mode. */
.set .L_SCTLR_EL1_ITD, 0x1 << 7
.set .L_SCTLR_EL1_RES1, (0x1 << 11) | (0x1 << 20) | (0x1 << 22) | (0x1 << 28) |
(0x1 << 29)
.set .L_sctlrval, .L_SCTLR_ELx_M | .L_SCTLR_ELx_C | .L_SCTLR_ELx_SA |
.L_SCTLR_EL1_ITD | .L_SCTLR_EL1_SED
.set .L_sctlrval, .L_sctlrval | .L_SCTLR_ELx_I | .L_SCTLR_EL1_SPAN |
.L_SCTLR_EL1_RES1

/**
 * This is a generic entry point for an image. It carries out the operations
 * required to prepare the
 * loaded image to be run. Specifically, it zeroes the bss section using
 * registers x25 and above,
 * prepares the stack, enables floating point, and sets up the exception vector.
 * It preserves x0-x3
 * for the Rust entry point, as these may contain boot parameters.
 */
.section .init.entry, "ax"
.global entry
entry:
    /* Load and apply the memory management configuration, ready to enable MMU
    and caches. */
    adrp x30, idmap
    msr ttbr0_el1, x30

    mov_i x30, .Lmairval
    msr mair_el1, x30

    mov_i x30, .L_tcrval
    /* Copy the supported PA range into TCR_EL1.IPS. */
    mrs x29, id_aa64mmfr0_el1
    bfi x30, x29, #32, #4

    msr tcr_el1, x30

    mov_i x30, .L_sctlrval

```

```

/*
 * Ensure everything before this point has completed, then invalidate any
potentially stale
 * local TLB entries before they start being used.
 */
isb
tlbi vmalle1
ic iallu
dsb nsh
isb

/*
 * Configure sctlr_el1 to enable MMU and cache and don't proceed until this
has completed.
 */
msr sctlr_el1, x30
isb

/* Disable trapping floating point access in EL1. */
mrs x30, cpacr_el1
orr x30, x30, #(0x3 << 20)
msr cpacr_el1, x30
isb

/* Zero out the bss section. */
adr_l x29, bss_begin
adr_l x30, bss_end
0:    cmp x29, x30
      b.hs 1f
      stp xzr, xzr, [x29], #16
      b 0b

1:    /* Prepare the stack. */
      adr_l x30, boot_stack_end
      mov sp, x30

/* Set up exception vector. */
adr x30, vector_table_el1
msr vbar_el1, x30

/* Call into Rust code. */
bl main

/* Loop forever waiting for interrupts. */
2:    wfi
      b 2b

```

*exceptions.S* (you shouldn't need to change this):

```

/*
 * Copyright 2023 Google LLC
 *
 * Licensed under the Apache License, Version 2.0 (the "License");
 * you may not use this file except in compliance with the License.
 * You may obtain a copy of the License at
 *
 *     https://www.apache.org/licenses/LICENSE-2.0
 *
 * Unless required by applicable law or agreed to in writing, software
 * distributed under the License is distributed on an "AS IS" BASIS,
 * WITHOUT WARRANTIES OR CONDITIONS OF ANY KIND, either express or implied.
 * See the License for the specific language governing permissions and
 * limitations under the License.
 */

/**
 * Saves the volatile registers onto the stack. This currently takes 14
 * instructions, so it can be used in exception handlers with 18 instructions
 * left.
 *
 * On return, x0 and x1 are initialised to elr_el2 and spsr_el2 respectively,
 * which can be used as the first and second arguments of a subsequent call.
 */
.macro save_volatile_to_stack
    /* Reserve stack space and save registers x0-x18, x29 & x30. */
    stp x0, x1, [sp, #-(8 * 24)]!
    stp x2, x3, [sp, #8 * 2]
    stp x4, x5, [sp, #8 * 4]
    stp x6, x7, [sp, #8 * 6]
    stp x8, x9, [sp, #8 * 8]
    stp x10, x11, [sp, #8 * 10]
    stp x12, x13, [sp, #8 * 12]
    stp x14, x15, [sp, #8 * 14]
    stp x16, x17, [sp, #8 * 16]
    str x18, [sp, #8 * 18]
    stp x29, x30, [sp, #8 * 20]

    /*
     * Save elr_el1 & spsr_el1. This such that we can take nested exception
     * and still be able to unwind.
     */
    mrs x0, elr_el1
    mrs x1, spsr_el1
    stp x0, x1, [sp, #8 * 22]
.endm

/**
 * Restores the volatile registers from the stack. This currently takes 14
 * instructions, so it can be used in exception handlers while still leaving 18
 * instructions left; if paired with save_volatile_to_stack, there are 4
 * instructions to spare.
 */
.macro restore_volatile_from_stack

```

```

/* Restore registers x2-x18, x29 & x30. */
ldp x2, x3, [sp, #8 * 2]
ldp x4, x5, [sp, #8 * 4]
ldp x6, x7, [sp, #8 * 6]
ldp x8, x9, [sp, #8 * 8]
ldp x10, x11, [sp, #8 * 10]
ldp x12, x13, [sp, #8 * 12]
ldp x14, x15, [sp, #8 * 14]
ldp x16, x17, [sp, #8 * 16]
ldr x18, [sp, #8 * 18]
ldp x29, x30, [sp, #8 * 20]

/* Restore registers elr_el1 & spsr_el1, using x0 & x1 as scratch. */
ldp x0, x1, [sp, #8 * 22]
msr elr_el1, x0
msr spsr_el1, x1

/* Restore x0 & x1, and release stack space. */
ldp x0, x1, [sp], #8 * 24
.endm

/**
 * This is a generic handler for exceptions taken at the current EL while using
 * SP0. It behaves similarly to the SPx case by first switching to SPx, doing
 * the work, then switching back to SP0 before returning.
 *
 * Switching to SPx and calling the Rust handler takes 16 instructions. To
 * restore and return we need an additional 16 instructions, so we can implement
 * the whole handler within the allotted 32 instructions.
 */
.macro current_exception_sp0 handler:req
    msr spsel, #1
    save_volatile_to_stack
    bl \handler
    restore_volatile_from_stack
    msr spsel, #0
    eret
.endm

/**
 * This is a generic handler for exceptions taken at the current EL while using
 * SPx. It saves volatile registers, calls the Rust handler, restores volatile
 * registers, then returns.
 *
 * This also works for exceptions taken from EL0, if we don't care about
 * non-volatile registers.
 *
 * Saving state and jumping to the Rust handler takes 15 instructions, and
 * restoring and returning also takes 15 instructions, so we can fit the whole
 * handler in 30 instructions, under the limit of 32.
 */
.macro current_exception_spx handler:req
    save_volatile_to_stack
    bl \handler

```

```
    restore_volatile_from_stack
    eret
.endm

.section .text.vector_table_el1, "ax"
.global vector_table_el1
.balign 0x800
vector_table_el1:
sync_cur_sp0:
    current_exception_sp0 sync_exception_current

.balign 0x80
irq_cur_sp0:
    current_exception_sp0 irq_current

.balign 0x80
fiq_cur_sp0:
    current_exception_sp0 fiq_current

.balign 0x80
serr_cur_sp0:
    current_exception_sp0 serr_current

.balign 0x80
sync_cur_spx:
    current_exception_spx sync_exception_current

.balign 0x80
irq_cur_spx:
    current_exception_spx irq_current

.balign 0x80
fiq_cur_spx:
    current_exception_spx fiq_current

.balign 0x80
serr_cur_spx:
    current_exception_spx serr_current

.balign 0x80
sync_lower_64:
    current_exception_spx sync_lower

.balign 0x80
irq_lower_64:
    current_exception_spx irq_lower

.balign 0x80
fiq_lower_64:
    current_exception_spx fiq_lower

.balign 0x80
serr_lower_64:
    current_exception_spx serr_lower
```



```
.balign 0x80  
sync_lower_32:  
    current_exception_spx sync_lower
```

```
.balign 0x80  
irq_lower_32:  
    current_exception_spx irq_lower
```

```
.balign 0x80  
fiq_lower_32:  
    current_exception_spx fiq_lower
```

```
.balign 0x80  
serr_lower_32:  
    current_exception_spx serr_lower
```

*idmap.S* (you shouldn't need to change this):

```

/*
 * Copyright 2023 Google LLC
 *
 * Licensed under the Apache License, Version 2.0 (the "License");
 * you may not use this file except in compliance with the License.
 * You may obtain a copy of the License at
 *
 *     https://www.apache.org/licenses/LICENSE-2.0
 *
 * Unless required by applicable law or agreed to in writing, software
 * distributed under the License is distributed on an "AS IS" BASIS,
 * WITHOUT WARRANTIES OR CONDITIONS OF ANY KIND, either express or implied.
 * See the License for the specific language governing permissions and
 * limitations under the License.
 */

.set .L_TT_TYPE_BLOCK, 0x1
.set .L_TT_TYPE_PAGE, 0x3
.set .L_TT_TYPE_TABLE, 0x3

/* Access flag. */
.set .L_TT_AF, 0x1 << 10
/* Not global. */
.set .L_TT_NG, 0x1 << 11
.set .L_TT_XN, 0x3 << 53

.set .L_TT_MT_DEV, 0x0 << 2 // MAIR #0 (DEV_nGnRE)
.set .L_TT_MT_MEM, (0x1 << 2) | (0x3 << 8) // MAIR #1 (MEM_WBWA), inner
shareable

.set .L_BLOCK_DEV, .L_TT_TYPE_BLOCK | .L_TT_MT_DEV | .L_TT_AF | .L_TT_XN
.set .L_BLOCK_MEM, .L_TT_TYPE_BLOCK | .L_TT_MT_MEM | .L_TT_AF | .L_TT_NG

.section ".rodata.idmap", "a", %progbits
.global idmap
.align 12
idmap:
    /* level 1 */
    .quad .L_BLOCK_DEV | 0x0 // 1 GiB of device
mappings
    .quad .L_BLOCK_MEM | 0x40000000 // 1 GiB of DRAM
    .fill 254, 8, 0x0 // 254 GiB of unmapped VA
space
    .quad .L_BLOCK_DEV | 0x4000000000 // 1 GiB of device mappings
    .fill 255, 8, 0x0 // 255 GiB of remaining
VA space

```

*image.ld* (you shouldn't need to change this):

```

/*
 * Copyright 2023 Google LLC
 *
 * Licensed under the Apache License, Version 2.0 (the "License");
 * you may not use this file except in compliance with the License.
 * You may obtain a copy of the License at
 *
 *     https://www.apache.org/licenses/LICENSE-2.0
 *
 * Unless required by applicable law or agreed to in writing, software
 * distributed under the License is distributed on an "AS IS" BASIS,
 * WITHOUT WARRANTIES OR CONDITIONS OF ANY KIND, either express or implied.
 * See the License for the specific language governing permissions and
 * limitations under the License.
 */

/*
 * Code will start running at this symbol which is placed at the start of the
 * image.
 */
ENTRY(entry)

MEMORY
{
    image : ORIGIN = 0x40080000, LENGTH = 2M
}

SECTIONS
{
    /*
     * Collect together the code.
     */
    .init : ALIGN(4096) {
        text_begin = .;
        *(.init.entry)
        *(.init.*)
    } >image
    .text : {
        *(.text.*)
    } >image
    text_end = .;

    /*
     * Collect together read-only data.
     */
    .rodata : ALIGN(4096) {
        rodata_begin = .;
        *(.rodata.*)
    } >image
    .got : {
        *(.got)
    } >image
    rodata_end = .;
}

```

```

/*
 * Collect together the read-write data including .bss at the end which
 * will be zero'd by the entry code.
 */
.data : ALIGN(4096) {
    data_begin = .;
    *(.data.*)
    /*
     * The entry point code assumes that .data is a multiple of 32
     * bytes long.
     */
    . = ALIGN(32);
    data_end = .;
} >image

/* Everything beyond this point will not be included in the binary. */
bin_end = .;

/* The entry point code assumes that .bss is 16-byte aligned. */
.bss : ALIGN(16) {
    bss_begin = .;
    *(.bss.*)
    *(COMMON)
    . = ALIGN(16);
    bss_end = .;
} >image

.stack (NOLOAD) : ALIGN(4096) {
    boot_stack_begin = .;
    . += 40 * 4096;
    . = ALIGN(4096);
    boot_stack_end = .;
} >image

. = ALIGN(4K);
PROVIDE(dma_region = .);

/*
 * Remove unused sections from the image.
 */
/DISCARD/ : {
    /* The image loads itself so doesn't need these sections. */
    *(.gnu.hash)
    *(.hash)
    *(.interp)
    *(.eh_frame_hdr)
    *(.eh_frame)
    *(.note.gnu.build-id)
}
}

```

*Makefile* (you shouldn't need to change this):

```
# Copyright 2023 Google LLC
#
# Licensed under the Apache License, Version 2.0 (the "License");
# you may not use this file except in compliance with the License.
# You may obtain a copy of the License at
#
#     http://www.apache.org/licenses/LICENSE-2.0
#
# Unless required by applicable law or agreed to in writing, software
# distributed under the License is distributed on an "AS IS" BASIS,
# WITHOUT WARRANTIES OR CONDITIONS OF ANY KIND, either express or implied.
# See the License for the specific language governing permissions and
# limitations under the License.

.PHONY: build qemu_minimal qemu qemu_logger

all: rtc.bin

build:
    cargo build

rtc.bin: build
    cargo objcopy -- -O binary $@

qemu: rtc.bin
    qemu-system-aarch64 -machine virt,gic-version=3 -cpu max -serial mon:stdio -
display none -kernel $< -s

clean:
    cargo clean
    rm -f *.bin
```

*.cargo/config.toml* (you shouldn't need to change this):

```
[build]
target = "aarch64-unknown-none"
rustflags = ["-C", "link-arg=-Timage.ld"]
```

Run the code in QEMU with `make qemu` .

# Bare Metal Rust Afternoon

## RTC driver

[\(back to exercise\)](#)

*main.rs:*

```

#![no_main]
#![no_std]

mod exceptions;
mod logger;
mod pl011;
mod pl031;

use crate::pl031::Rtc;
use arm_gic::{irq_enable, wfi, IntId, Trigger};
use chrono::{TimeZone, Utc};
use core::hint::spin_loop;
use crate::pl011::Uart;
use arm_gic::gicv3::GicV3;
use core::panic::PanicInfo;
use log::{error, info, trace, LevelFilter};
use smccc::psci::system_off;
use smccc::Hvc;

/// Base addresses of the GICv3.
const GICD_BASE_ADDRESS: *mut u64 = 0x800_0000 as _;
const GICR_BASE_ADDRESS: *mut u64 = 0x80A_0000 as _;

/// Base address of the primary PL011 UART.
const PL011_BASE_ADDRESS: *mut u32 = 0x900_0000 as _;

/// Base address of the PL031 RTC.
const PL031_BASE_ADDRESS: *mut u32 = 0x901_0000 as _;
/// The IRQ used by the PL031 RTC.
const PL031_IRQ: IntId = IntId::spi(2);

// SAFETY: There is no other global function of this name.
#[unsafe(no_mangle)]
extern "C" fn main(x0: u64, x1: u64, x2: u64, x3: u64) {
    // SAFETY: `PL011_BASE_ADDRESS` is the base address of a PL011 device, and
    // nothing else accesses that address range.
    let uart = unsafe { Uart::new(PL011_BASE_ADDRESS) };
    logger::init(uart, LevelFilter::Trace).unwrap();

    info!("main({:#x}, {:#x}, {:#x}, {:#x})", x0, x1, x2, x3);

    // SAFETY: `GICD_BASE_ADDRESS` and `GICR_BASE_ADDRESS` are the base
    // addresses of a GICv3 distributor and redistributor respectively, and
    // nothing else accesses those address ranges.
    let mut gic =
        unsafe { GicV3::new(GICD_BASE_ADDRESS, GICR_BASE_ADDRESS, 1, 0x20000) };
    gic.setup(0);

    // SAFETY: `PL031_BASE_ADDRESS` is the base address of a PL031 device, and
    // nothing else accesses that address range.
    let mut rtc = unsafe { Rtc::new(PL031_BASE_ADDRESS) };
    let timestamp = rtc.read();
    let time = Utc.timestamp_opt(timestamp.into(), 0).unwrap();
    info!("RTC: {time}");
}

```

```

GicV3::set_priority_mask(0xff);
gic.set_interrupt_priority(PL031_IRQ, None, 0x80);
gic.set_trigger(PL031_IRQ, None, Trigger::Level);
irq_enable();
gic.enable_interrupt(PL031_IRQ, None, true);

// Wait for 3 seconds, without interrupts.
let target = timestamp + 3;
rtc.set_match(target);
info!("Waiting for {}", Utc.timestamp_opt(target.into(), 0).unwrap());
trace!(
    "matched={}, interrupt_pending={}",
    rtc.matched(),
    rtc.interrupt_pending()
);
while !rtc.matched() {
    spin_loop();
}
trace!(
    "matched={}, interrupt_pending={}",
    rtc.matched(),
    rtc.interrupt_pending()
);
info!("Finished waiting");

// Wait another 3 seconds for an interrupt.
let target = timestamp + 6;
info!("Waiting for {}", Utc.timestamp_opt(target.into(), 0).unwrap());
rtc.set_match(target);
rtc.clear_interrupt();
rtc.enable_interrupt(true);
trace!(
    "matched={}, interrupt_pending={}",
    rtc.matched(),
    rtc.interrupt_pending()
);
while !rtc.interrupt_pending() {
    wfi();
}
trace!(
    "matched={}, interrupt_pending={}",
    rtc.matched(),
    rtc.interrupt_pending()
);
info!("Finished waiting");

system_off::<Hvc>().unwrap();
}

#[panic_handler]
fn panic(info: &PanicInfo) -> ! {
    error!("{info}");
    system_off::<Hvc>().unwrap();
}

```



```
    loop {}  
}
```

*p/031.rs:*

```

#[repr(C, align(4))]
struct Registers {
    /// Data register
    dr: u32,
    /// Match register
    mr: u32,
    /// Load register
    lr: u32,
    /// Control register
    cr: u8,
    _reserved0: [u8; 3],
    /// Interrupt Mask Set or Clear register
    imsc: u8,
    _reserved1: [u8; 3],
    /// Raw Interrupt Status
    ris: u8,
    _reserved2: [u8; 3],
    /// Masked Interrupt Status
    mis: u8,
    _reserved3: [u8; 3],
    /// Interrupt Clear Register
    icr: u8,
    _reserved4: [u8; 3],
}

/// Driver for a PL031 real-time clock.
#[derive(Debug)]
pub struct Rtc {
    registers: *mut Registers,
}

impl Rtc {
    /// Constructs a new instance of the RTC driver for a PL031 device at the
    /// given base address.
    ///
    /// # Safety
    ///
    /// The given base address must point to the MMIO control registers of a
    /// PL031 device, which must be mapped into the address space of the process
    /// as device memory and not have any other aliases.
    pub unsafe fn new(base_address: *mut u32) -> Self {
        Self { registers: base_address as *mut Registers }
    }

    /// Reads the current RTC value.
    pub fn read(&self) -> u32 {
        // SAFETY: We know that self.registers points to the control registers
        // of a PL031 device which is appropriately mapped.
        unsafe { (&raw const (*self.registers).dr).read_volatile() }
    }

    /// Writes a match value. When the RTC value matches this then an interrupt
    /// will be generated (if it is enabled).
    pub fn set_match(&mut self, value: u32) {

```

```

// SAFETY: We know that self.registers points to the control registers
// of a PL031 device which is appropriately mapped.
unsafe { (&raw mut (*self.registers).mr).write_volatile(value) }
}

/// Returns whether the match register matches the RTC value, whether or not
/// the interrupt is enabled.
pub fn matched(&self) -> bool {
    // SAFETY: We know that self.registers points to the control registers
    // of a PL031 device which is appropriately mapped.
    let ris = unsafe { (&raw const (*self.registers).ris).read_volatile() };
    (ris & 0x01) != 0
}

/// Returns whether there is currently an interrupt pending.
///
/// This should be true if and only if `matched` returns true and the
/// interrupt is masked.
pub fn interrupt_pending(&self) -> bool {
    // SAFETY: We know that self.registers points to the control registers
    // of a PL031 device which is appropriately mapped.
    let ris = unsafe { (&raw const (*self.registers).mis).read_volatile() };
    (ris & 0x01) != 0
}

/// Sets or clears the interrupt mask.
///
/// When the mask is true the interrupt is enabled; when it is false the
/// interrupt is disabled.
pub fn enable_interrupt(&mut self, mask: bool) {
    let imsc = if mask { 0x01 } else { 0x00 };
    // SAFETY: We know that self.registers points to the control registers
    // of a PL031 device which is appropriately mapped.
    unsafe { (&raw mut (*self.registers).imsc).write_volatile(imsc) }
}

/// Clears a pending interrupt, if any.
pub fn clear_interrupt(&mut self) {
    // SAFETY: We know that self.registers points to the control registers
    // of a PL031 device which is appropriately mapped.
    unsafe { (&raw mut (*self.registers).icr).write_volatile(0x01) }
}

// SAFETY: `Rtc` just contains a pointer to device memory, which can be
// accessed from any context.
unsafe impl Send for Rtc {}

```

# Welcome to Concurrency in Rust

Rust has full support for concurrency using OS threads with mutexes and channels.

The Rust type system plays an important role in making many concurrency bugs compile time bugs. This is often referred to as *fearless concurrency* since you can rely on the compiler to ensure correctness at runtime.

## Schedule

Including 10 minute breaks, this session should take about 3 hours and 20 minutes. It contains:

Segment	Duration
Threads	30 minutes
Channels	20 minutes
Send and Sync	15 minutes
Shared State	30 minutes
Exercises	1 hour and 10 minutes

### ▼ *Speaker Notes*

- Rust lets us access OS concurrency toolkit: threads, sync. primitives, etc.
- The type system gives us safety for concurrency without any special features.
- The same tools that help with “concurrent” access in a single thread (e.g., a called function that might mutate an argument or save references to it to read later) save us from multi-threading issues.

# Threads

This segment should take about 30 minutes. It contains:

<b>Slide</b>	<b>Duration</b>
Plain Threads	15 minutes
Scoped Threads	15 minutes

# Plain Threads

Rust threads work similarly to threads in other languages:

```
1 use std::thread;
2 use std::time::Duration;
3
4 fn main() {
5     thread::spawn(|| {
6         for i in 0..10 {
7             println!("Count in thread: {i}!");
8             thread::sleep(Duration::from_millis(5));
9         }
10    });
11
12    for i in 0..5 {
13        println!("Main thread: {i}");
14        thread::sleep(Duration::from_millis(5));
15    }
16 }
```

- Spawning new threads does not automatically delay program termination at the end of `main`.
- Thread panics are independent of each other.
  - Panics can carry a payload, which can be unpacked with `Any::downcast_ref`.

## ▼ *Speaker Notes*

This slide should take about 15 minutes.

- Run the example.
  - 5ms timing is loose enough that main and spawned threads stay mostly in lockstep.
  - Notice that the program ends before the spawned thread reaches 10!
  - This is because `main` ends the program and spawned threads do not make it persist.
    - Compare to `pthread` / C++ `std::thread` / `boost::thread` if desired.
- How do we wait around for the spawned thread to complete?
- `thread::spawn` returns a `JoinHandle`. Look at the docs.
  - `JoinHandle` has a `.join()` method that blocks.

- Use `let handle = thread::spawn(...)` and later `handle.join()` to wait for the thread to finish and have the program count all the way to 10.
- Now what if we want to return a value?
- Look at docs again:
  - `thread::spawn`'s closure returns `T`
  - `JoinHandle` `.join()` returns `thread::Result<T>`
- Use the `Result` return value from `handle.join()` to get access to the returned value.
- Ok, what about the other case?
  - Trigger a panic in the thread. Note that this doesn't panic `main`.
  - Access the panic payload. This is a good time to talk about `Any`.
- Now we can return values from threads! What about taking inputs?
  - Capture something by reference in the thread closure.
  - An error message indicates we must move it.
  - Move it in, see we can compute and then return a derived value.
- If we want to borrow?
  - Main kills child threads when it returns, but another function would just return and leave them running.
  - That would be stack use-after-return, which violates memory safety!
  - How do we avoid this? See next slide.

# Scoped Threads

Normal threads cannot borrow from their environment:

```
1 use std::thread;
2
3 fn foo() {
4     let s = String::from("Hello");
5     thread::spawn(|| {
6         dbg!(s.len());
7     });
8 }
9
10 fn main() {
11     foo();
12 }
```

However, you can use a [scoped thread](#) for this:

```
1 use std::thread;
2
3 fn foo() {
4     let s = String::from("Hello");
5     thread::scope(|scope| {
6         scope.spawn(|| {
7             dbg!(s.len());
8         });
9     });
10 }
11
12 fn main() {
13     foo();
14 }
```

## ▼ *Speaker Notes*

This slide should take about 13 minutes.

- The reason for that is that when the `thread::scope` function completes, all the threads are guaranteed to be joined, so they can return borrowed data.
- Normal Rust borrowing rules apply: you can either borrow mutably by one thread, or immutably by any number of threads.



# Channels

This segment should take about 20 minutes. It contains:

Slide	Duration
Senders and Receivers	10 minutes
Unbounded Channels	2 minutes
Bounded Channels	10 minutes

# Senders and Receivers

Rust channels have two parts: a `Sender<T>` and a `Receiver<T>`. The two parts are connected via the channel, but you only see the end-points.

```
1 use std::sync::mpsc;
2
3 fn main() {
4     let (tx, rx) = mpsc::channel();
5
6     tx.send(10).unwrap();
7     tx.send(20).unwrap();
8
9     println!("Received: {:?}", rx.recv());
10    println!("Received: {:?}", rx.recv());
11
12    let tx2 = tx.clone();
13    tx2.send(30).unwrap();
14    println!("Received: {:?}", rx.recv());
15 }
```

## ▼ *Speaker Notes*

This slide should take about 9 minutes.

- `mpsc` stands for Multi-Producer, Single-Consumer. `Sender` and `SyncSender` implement `clone` (so you can make multiple producers) but `Receiver` does not.
- `send()` and `recv()` return `Result`. If they return `Err`, it means the counterpart `Sender` or `Receiver` is dropped and the channel is closed.

# Unbounded Channels

You get an unbounded and asynchronous channel with `mpsc::channel()`:

```
1 use std::sync::mpsc;
2 use std::thread;
3 use std::time::Duration;
4
5 fn main() {
6     let (tx, rx) = mpsc::channel();
7
8     thread::spawn(move || {
9         let thread_id = thread::current().id();
10        for i in 0..10 {
11            tx.send(format!("Message {i}")).unwrap();
12            println!("{thread_id:?}: sent Message {i}");
13        }
14        println!("{thread_id:?}: done");
15    });
16    thread::sleep(Duration::from_millis(100));
17
18    for msg in rx.iter() {
19        println!("Main: got {msg}");
20    }
21 }
```

## ▼ Speaker Notes

This slide should take about 2 minutes.

- An unbounded channel will allocate as much space as is necessary to store pending messages. The `send()` method will not block the calling thread.
- A call to `send()` will abort with an error (that is why it returns `Result`) if the channel is closed. A channel is closed when the receiver is dropped.

# Bounded Channels

With bounded (synchronous) channels, `send()` can block the current thread:

```
1 use std::sync::mpsc;
2 use std::thread;
3 use std::time::Duration;
4
5 fn main() {
6     let (tx, rx) = mpsc::sync_channel(3);
7
8     thread::spawn(move || {
9         let thread_id = thread::current().id();
10        for i in 0..10 {
11            tx.send(format!("Message {i}")).unwrap();
12            println!("{thread_id:?}: sent Message {i}");
13        }
14        println!("{thread_id:?}: done");
15    });
16    thread::sleep(Duration::from_millis(100));
17
18    for msg in rx.iter() {
19        println!("Main: got {msg}");
20    }
21 }
```

## ▼ Speaker Notes

This slide should take about 8 minutes.

- Calling `send()` will block the current thread until there is space in the channel for the new message. The thread can be blocked indefinitely if there is nobody who reads from the channel.
- Like unbounded channels, a call to `send()` will abort with an error if the channel is closed.
- A bounded channel with a size of zero is called a “rendezvous channel”. Every send will block the current thread until another thread calls `recv()`.

# Send and Sync

This segment should take about 15 minutes. It contains:

Slide	Duration
Marker Traits	2 minutes
Send	2 minutes
Sync	2 minutes
Examples	10 minutes

# Marker Traits

How does Rust know to forbid shared access across threads? The answer is in two traits:

- `Send`: a type `T` is `Send` if it is safe to move a `T` across a thread boundary.
- `Sync`: a type `T` is `Sync` if it is safe to move a `&T` across a thread boundary.

`Send` and `Sync` are [unsafe traits](#). The compiler will automatically derive them for your types as long as they only contain `Send` and `Sync` types. You can also implement them manually when you know it is valid.

## ▼ *Speaker Notes*

This slide should take about 2 minutes.

- One can think of these traits as markers that the type has certain thread-safety properties.
- They can be used in the generic constraints as normal traits.

# Send

---

A type  $T$  is `Send` if it is safe to move a  $T$  value to another thread.

---

The effect of moving ownership to another thread is that *destructors* will run in that thread. So the question is when you can allocate a value in one thread and deallocate it in another.

## ▼ *Speaker Notes*

This slide should take about 2 minutes.

As an example, a connection to the SQLite library must only be accessed from a single thread.

# Sync

---

A type  $T$  is `Sync` if it is safe to access a  $T$  value from multiple threads at the same time.

---

More precisely, the definition is:

---

$T$  is `Sync` if and only if  $\&T$  is `Send`

---

## ▼ *Speaker Notes*

This slide should take about 2 minutes.

This statement is essentially a shorthand way of saying that if a type is thread-safe for shared use, it is also thread-safe to pass references of it across threads.

This is because if a type is `Sync` it means that it can be shared across multiple threads without the risk of data races or other synchronization issues, so it is safe to move it to another thread. A reference to the type is also safe to move to another thread, because the data it references can be accessed from any thread safely.



# Examples

## Send + Sync

Most types you come across are `Send + Sync` :

- `i8`, `f32`, `bool`, `char`, `&str`, ...
- `(T1, T2)`, `[T; N]`, `&[T]`, `struct { x: T }`, ...
- `String`, `Option<T>`, `Vec<T>`, `Box<T>`, ...
- `Arc<T>` : Explicitly thread-safe via atomic reference count.
- `Mutex<T>` : Explicitly thread-safe via internal locking.
- `mpsc::Sender<T>` : As of 1.72.0.
- `AtomicBool`, `AtomicU8`, ...: Uses special atomic instructions.

The generic types are typically `Send + Sync` when the type parameters are `Send + Sync` .

## Send + !Sync

These types can be moved to other threads, but they're not thread-safe. Typically because of interior mutability:

- `mpsc::Receiver<T>`
- `Cell<T>`
- `RefCell<T>`

## !Send + Sync

These types are safe to access (via shared references) from multiple threads, but they cannot be moved to another thread:

- `MutexGuard<T: Sync>` : Uses OS level primitives which must be deallocated on the thread which created them. However, an already-locked mutex can have its guarded variable read by any thread with which the guard is shared.

# !Send + !Sync

These types are not thread-safe and cannot be moved to other threads:

- `Rc<T>` : each `Rc<T>` has a reference to an `RcBox<T>`, which contains a non-atomic reference count.
- `*const T`, `*mut T` : Rust assumes raw pointers may have special concurrency considerations.

# Shared State

This segment should take about 30 minutes. It contains:

Slide	Duration
Arc	5 minutes
Mutex	15 minutes
Example	10 minutes

# Arc

`Arc<T>` allows shared read-only access via `Arc::clone` :

```
1 use std::sync::Arc;
2 use std::thread;
3
4 fn main() {
5     let v = Arc::new(vec![10, 20, 30]);
6     let mut handles = Vec::new();
7     for _ in 0..5 {
8         let v = Arc::clone(&v);
9         handles.push(thread::spawn(move || {
10             let thread_id = thread::current().id();
11             println!("{thread_id:?}: {v:?}");
12         }));
13     }
14
15     handles.into_iter().for_each(|h| h.join().unwrap());
16     println!("v: {v:?}");
17 }
```

## ▼ Speaker Notes

This slide should take about 5 minutes.

- `Arc` stands for “Atomic Reference Counted”, a thread safe version of `Rc` that uses atomic operations.
- `Arc<T>` implements `clone` whether or not `T` does. It implements `Send` and `Sync` if and only if `T` implements them both.
- `Arc::clone()` has the cost of atomic operations that get executed, but after that the use of the `T` is free.
- Beware of reference cycles, `Arc` does not use a garbage collector to detect them.
  - `std::sync::Weak` can help.

# Mutex

`Mutex<T>` ensures mutual exclusion *and* allows mutable access to `T` behind a read-only interface (another form of [interior mutability](#)):

```

1 use std::sync::Mutex;
2
3 fn main() {
4     let v = Mutex::new(vec![10, 20, 30]);
5     println!("v: {:?}", v.lock().unwrap());
6
7     {
8         let mut guard = v.lock().unwrap();
9         guard.push(40);
10    }
11
12    println!("v: {:?}", v.lock().unwrap());
13 }
```

Notice how we have a `impl<T: Send> Sync for Mutex<T>` blanket implementation.

## ▼ *Speaker Notes*

This slide should take about 14 minutes.

- `Mutex` in Rust looks like a collection with just one element — the protected data.
  - It is not possible to forget to acquire the mutex before accessing the protected data.
- You can get an `&mut T` from an `&Mutex<T>` by taking the lock. The `MutexGuard` ensures that the `&mut T` doesn't outlive the lock being held.
- `Mutex<T>` implements both `Send` and `Sync` if and only if `T` implements `Send`.
- A read-write lock counterpart: `RwLock`.
- Why does `lock()` return a `Result`?
  - If the thread that held the `Mutex` panicked, the `Mutex` becomes “poisoned” to signal that the data it protected might be in an inconsistent state. Calling `lock()` on a poisoned mutex fails with a `PoisonError`. You can call `into_inner()` on the error to recover the data regardless.

# Example

Let us see `Arc` and `Mutex` in action:

```

1 use std::thread;
2 // use std::sync::{Arc, Mutex};
3
4 fn main() {
5     let v = vec![10, 20, 30];
6     let handle = thread::spawn(|| {
7         v.push(10);
8     });
9     v.push(1000);
10
11     handle.join().unwrap();
12     println!("v: {v:?}");
13 }
```

## ▼ Speaker Notes

This slide should take about 8 minutes.

Possible solution:

```

1 use std::sync::{Arc, Mutex};
2 use std::thread;
3
4 fn main() {
5     let v = Arc::new(Mutex::new(vec![10, 20, 30]));
6
7     let v2 = Arc::clone(&v);
8     let handle = thread::spawn(move || {
9         let mut v2 = v2.lock().unwrap();
10        v2.push(10);
11    });
12
13    {
14        let mut v = v.lock().unwrap();
15        v.push(1000);
16    }
17
18    handle.join().unwrap();
19
20    println!("v: {v:?}");
21 }
```

Notable parts:

- `v` is wrapped in both `Arc` and `Mutex`, because their concerns are orthogonal.

- Wrapping a `Mutex` in an `Arc` is a common pattern to share mutable state between threads.
- `v: Arc<_>` needs to be cloned as `v2` before it can be moved into another thread. Note `move` was added to the lambda signature.
- Blocks are introduced to narrow the scope of the `LockGuard` as much as possible.

# Exercises

This segment should take about 1 hour and 10 minutes. It contains:

<b>Slide</b>	<b>Duration</b>
Dining Philosophers	20 minutes
Multi-threaded Link Checker	20 minutes
Solutions	30 minutes



# Dining Philosophers

The dining philosophers problem is a classic problem in concurrency:

---

Five philosophers dine together at the same table. Each philosopher has their own place at the table. There is a chopstick between each plate. The dish served is spaghetti which requires two chopsticks to eat. Each philosopher can only alternately think and eat. Moreover, a philosopher can only eat their spaghetti when they have both a left and right chopstick. Thus two chopsticks will only be available when their two nearest neighbors are thinking, not eating. After an individual philosopher finishes eating, they will put down both chopsticks.

---

You will need a local [Cargo installation](#) for this exercise. Copy the code below to a file called `src/main.rs`, fill out the blanks, and test that `cargo run` does not deadlock:

```

use std::sync::{mpsc, Arc, Mutex};
use std::thread;
use std::time::Duration;

struct Chopstick;

struct Philosopher {
    name: String,
    // left_chopstick: ...
    // right_chopstick: ...
    // thoughts: ...
}

impl Philosopher {
    fn think(&self) {
        self.thoughts
            .send(format!("Eureka! {} has a new idea!", &self.name))
            .unwrap();
    }

    fn eat(&self) {
        // Pick up chopsticks...
        println!("{}", &self.name);
        thread::sleep(Duration::from_millis(10));
    }
}

static PHILOSOPHERS: &[&str] =
    &["Socrates", "Hypatia", "Plato", "Aristotle", "Pythagoras"];

fn main() {
    // Create chopsticks

    // Create philosophers

    // Make each of them think and eat 100 times

    // Output their thoughts
}

```

You can use the following `Cargo.toml` :

```

[package]
name = "dining-philosophers"
version = "0.1.0"
edition = "2021"

```

### ▼ *Speaker Notes*

This slide should take about 20 minutes.

- Encourage students to focus first on implementing a solution that “mostly” works.
- The deadlock in the simplest solution is a general concurrency problem and highlights that Rust does not automatically prevent this sort of bug.

# Multi-threaded Link Checker

Let us use our new knowledge to create a multi-threaded link checker. It should start at a webpage and check that links on the page are valid. It should recursively check other pages on the same domain and keep doing this until all pages have been validated.

For this, you will need an HTTP client such as `reqwest`. You will also need a way to find links, we can use `scraper`. Finally, we'll need some way of handling errors, we will use `thiserror`.

Create a new Cargo project and `reqwest` it as a dependency with:

```
cargo new link-checker
cd link-checker
cargo add --features blocking,rustls-tls reqwest
cargo add scraper
cargo add thiserror
```

---

If `cargo add` fails with `error: no such subcommand`, then please edit the `Cargo.toml` file by hand. Add the dependencies listed below.

---

The `cargo add` calls will update the `Cargo.toml` file to look like this:

```
[package]
name = "link-checker"
version = "0.1.0"
edition = "2021"
publish = false

[dependencies]
reqwest = { version = "0.11.12", features = ["blocking", "rustls-tls"] }
scraper = "0.13.0"
thiserror = "1.0.37"
```

You can now download the start page. Try with a small site such as `https://www.google.org/`.

Your `src/main.rs` file should look something like this:

```

use request::blocking::Client;
use request::Url;
use scraper::{Html, Selector};
use thiserror::Error;

#[derive(Error, Debug)]
enum Error {
    #[error("request error: {0}")]
    RequestError(#[from] request::Error),
    #[error("bad http response: {0}")]
    BadResponse(String),
}

#[derive(Debug)]
struct CrawlCommand {
    url: Url,
    extract_links: bool,
}

fn visit_page(client: &Client, command: &CrawlCommand) -> Result<Vec<Url>, Error>
{
    println!("Checking {:#}", command.url);
    let response = client.get(command.url.clone()).send()?;
    if !response.status().is_success() {
        return Err(Error::BadResponse(response.status().to_string()));
    }

    let mut link_urls = Vec::new();
    if !command.extract_links {
        return Ok(link_urls);
    }

    let base_url = response.url().to_owned();
    let body_text = response.text()?;
    let document = Html::parse_document(&body_text);

    let selector = Selector::parse("a").unwrap();
    let href_values = document
        .select(&selector)
        .filter_map(|element| element.value().attr("href"));
    for href in href_values {
        match base_url.join(href) {
            Ok(link_url) => {
                link_urls.push(link_url);
            }
            Err(err) => {
                println!("On {base_url:#}: ignored unparseable {href:?}: {err}");
            }
        }
    }
    Ok(link_urls)
}

fn main() {

```

```
let client = Client::new();
let start_url = Url::parse("https://www.google.org").unwrap();
let crawl_command = CrawlCommand{ url: start_url, extract_links: true };
match visit_page(&client, &crawl_command) {
    Ok(links) => println!("Links: {links:#?}"),
    Err(err) => println!("Could not extract links: {err:#?}"),
}
}
```

Run the code in `src/main.rs` with

```
cargo run
```

## Tasks

- Use threads to check the links in parallel: send the URLs to be checked to a channel and let a few threads check the URLs in parallel.
- Extend this to recursively extract links from all pages on the `www.google.org` domain. Put an upper limit of 100 pages or so so that you don't end up being blocked by the site.

### ▼ *Speaker Notes*

This slide should take about 20 minutes.

- This is a complex exercise and intended to give students an opportunity to work on a larger project than others. A success condition for this exercise is to get stuck on some "real" issue and work through it with the support of other students or the instructor.



# Solutions

## Dining Philosophers

```

use std::sync::{mpsc, Arc, Mutex};
use std::thread;
use std::time::Duration;

struct Chopstick;

struct Philosopher {
    name: String,
    left_chopstick: Arc<Mutex<Chopstick>>,
    right_chopstick: Arc<Mutex<Chopstick>>,
    thoughts: mpsc::SyncSender<String>,
}

impl Philosopher {
    fn think(&self) {
        self.thoughts
            .send(format!("Eureka! {} has a new idea!", &self.name))
            .unwrap();
    }

    fn eat(&self) {
        println!("{}", &self.name);
        let _left = self.left_chopstick.lock().unwrap();
        let _right = self.right_chopstick.lock().unwrap();

        println!("{}", &self.name);
        thread::sleep(Duration::from_millis(10));
    }
}

static PHILOSOPHERS: &[&str] =
    &["Socrates", "Hypatia", "Plato", "Aristotle", "Pythagoras"];

fn main() {
    let (tx, rx) = mpsc::sync_channel(10);

    let chopsticks = PHILOSOPHERS
        .iter()
        .map(|_| Arc::new(Mutex::new(Chopstick)))
        .collect::<Vec<_>>();

    for i in 0..chopsticks.len() {
        let tx = tx.clone();
        let mut left_chopstick = Arc::clone(&chopsticks[i]);
        let mut right_chopstick =

```



```
Arc::clone(&chopsticks[(i + 1) % chopsticks.len()]);

// To avoid a deadlock, we have to break the symmetry
// somewhere. This will swap the chopsticks without deinitializing
// either of them.
if i == chopsticks.len() - 1 {
    std::mem::swap(&mut left_chopstick, &mut right_chopstick);
}

let philosopher = Philosopher {
    name: PHILOSOPHERS[i].to_string(),
    thoughts: tx,
    left_chopstick,
    right_chopstick,
};

thread::spawn(move || {
    for _ in 0..100 {
        philosopher.eat();
        philosopher.think();
    }
});

drop(tx);
for thought in rx {
    println!("{}", thought);
}
}
```

# Link Checker

```

use std::sync::{mpsc, Arc, Mutex};
use std::thread;

use reqwest::blocking::Client;
use reqwest::Url;
use scraper::{Html, Selector};
use thiserror::Error;

#[derive(Error, Debug)]
enum Error {
    #[error("request error: {0}")]
    ReqwestError(#[from] reqwest::Error),
    #[error("bad http response: {0}")]
    BadResponse(String),
}

#[derive(Debug)]
struct CrawlCommand {
    url: Url,
    extract_links: bool,
}

fn visit_page(client: &Client, command: &CrawlCommand) -> Result<Vec<Url>, Error>
{
    println!("Checking {:#}", command.url);
    let response = client.get(command.url.clone()).send()?;
    if !response.status().is_success() {
        return Err(Error::BadResponse(response.status().to_string()));
    }

    let mut link_urls = Vec::new();
    if !command.extract_links {
        return Ok(link_urls);
    }

    let base_url = response.url().to_owned();
    let body_text = response.text()?;
    let document = Html::parse_document(&body_text);

    let selector = Selector::parse("a").unwrap();
    let href_values = document
        .select(&selector)
        .filter_map(|element| element.value().attr("href"));
    for href in href_values {
        match base_url.join(href) {
            Ok(link_url) => {
                link_urls.push(link_url);
            }
            Err(err) => {
                println!("On {base_url:#}: ignored unparsable {href:?}: {err}");
            }
        }
    }
}

```

```

    }
}
Ok(link_urls)
}

struct CrawlState {
    domain: String,
    visited_pages: std::collections::HashSet<String>,
}

impl CrawlState {
    fn new(start_url: &Url) -> CrawlState {
        let mut visited_pages = std::collections::HashSet::new();
        visited_pages.insert(start_url.as_str().to_string());
        CrawlState { domain: start_url.domain().unwrap().to_string(),
visited_pages }
    }

    /// Determine whether links within the given page should be extracted.
    fn should_extract_links(&self, url: &Url) -> bool {
        let Some(url_domain) = url.domain() else {
            return false;
        };
        url_domain == self.domain
    }

    /// Mark the given page as visited, returning false if it had already
    /// been visited.
    fn mark_visited(&mut self, url: &Url) -> bool {
        self.visited_pages.insert(url.as_str().to_string())
    }
}

type CrawlResult = Result<Vec<Url>, (Url, Error)>;
fn spawn_crawler_threads(
    command_receiver: mpsc::Receiver<CrawlCommand>,
    result_sender: mpsc::Sender<CrawlResult>,
    thread_count: u32,
) {
    let command_receiver = Arc::new(Mutex::new(command_receiver));

    for _ in 0..thread_count {
        let result_sender = result_sender.clone();
        let command_receiver = command_receiver.clone();
        thread::spawn(move || {
            let client = Client::new();
            loop {
                let command_result = {
                    let receiver_guard = command_receiver.lock().unwrap();
                    receiver_guard.recv()
                };
                let Ok(crawl_command) = command_result else {
                    // The sender got dropped. No more commands coming in.
                    break;
                }
            }
        });
    }
}

```

```

    };
    let crawl_result = match visit_page(&client, &crawl_command) {
        Ok(link_urls) => Ok(link_urls),
        Err(error) => Err((crawl_command.url, error)),
    };
    result_sender.send(crawl_result).unwrap();
}
});
}
}

fn control_crawl(
    start_url: Url,
    command_sender: mpsc::Sender<CrawlCommand>,
    result_receiver: mpsc::Receiver<CrawlResult>,
) -> Vec<Url> {
    let mut crawl_state = CrawlState::new(&start_url);
    let start_command = CrawlCommand { url: start_url, extract_links: true };
    command_sender.send(start_command).unwrap();
    let mut pending_urls = 1;

    let mut bad_urls = Vec::new();
    while pending_urls > 0 {
        let crawl_result = result_receiver.recv().unwrap();
        pending_urls -= 1;

        match crawl_result {
            Ok(link_urls) => {
                for url in link_urls {
                    if crawl_state.mark_visited(&url) {
                        let extract_links =
crawl_state.should_extract_links(&url);
                        let crawl_command = CrawlCommand { url, extract_links };
                        command_sender.send(crawl_command).unwrap();
                        pending_urls += 1;
                    }
                }
            }
            Err((url, error)) => {
                bad_urls.push(url);
                println!("Got crawling error: {:#}", error);
                continue;
            }
        }
    }
    bad_urls
}

fn check_links(start_url: Url) -> Vec<Url> {
    let (result_sender, result_receiver) = mpsc::channel::<CrawlResult>();
    let (command_sender, command_receiver) = mpsc::channel::<CrawlCommand>();
    spawn_crawler_threads(command_receiver, result_sender, 16);
    control_crawl(start_url, command_sender, result_receiver)
}

```

```
fn main() {  
    let start_url = reqwest::Url::parse("https://www.google.org").unwrap();  
    let bad_urls = check_links(start_url);  
    println!("Bad URLs: {:#?}", bad_urls);  
}
```

# Welcome

“Async” is a concurrency model where multiple tasks are executed concurrently by executing each task until it would block, then switching to another task that is ready to make progress. The model allows running a larger number of tasks on a limited number of threads. This is because the per-task overhead is typically very low and operating systems provide primitives for efficiently identifying I/O that is able to proceed.

Rust’s asynchronous operation is based on “futures”, which represent work that may be completed in the future. Futures are “polled” until they signal that they are complete.

Futures are polled by an async runtime, and several different runtimes are available.

## Comparisons

- Python has a similar model in its `asyncio`. However, its `Future` type is callback-based, and not polled. Async Python programs require a “loop”, similar to a runtime in Rust.
- JavaScript’s `Promise` is similar, but again callback-based. The language runtime implements the event loop, so many of the details of Promise resolution are hidden.

## Schedule

Including 10 minute breaks, this session should take about 3 hours and 20 minutes. It contains:

Segment	Duration
Async Basics	30 minutes
Channels and Control Flow	20 minutes
Pitfalls	55 minutes
Exercises	1 hour and 10 minutes

# Async Basics

This segment should take about 30 minutes. It contains:

Slide	Duration
async/await	10 minutes
Futures	4 minutes
Runtimes	10 minutes
Tasks	10 minutes

# async/await

At a high level, async Rust code looks very much like “normal” sequential code:

```
1 use futures::executor::block_on;
2
3 async fn count_to(count: i32) {
4     for i in 0..count {
5         println!("Count is: {i}!");
6     }
7 }
8
9 async fn async_main(count: i32) {
10     count_to(count).await;
11 }
12
13 fn main() {
14     block_on(async_main(10));
15 }
```

## ▼ Speaker Notes

This slide should take about 6 minutes.

Key points:

- Note that this is a simplified example to show the syntax. There is no long running operation or any real concurrency in it!
- The “async” keyword is syntactic sugar. The compiler replaces the return type with a future.
- You cannot make `main` async, without additional instructions to the compiler on how to use the returned future.
- You need an executor to run async code. `block_on` blocks the current thread until the provided future has run to completion.
- `.await` asynchronously waits for the completion of another operation. Unlike `block_on`, `.await` doesn't block the current thread.
- `.await` can only be used inside an `async` function (or `block`; these are introduced later).



# Futures

`Future` is a trait, implemented by objects that represent an operation that may not be complete yet. A future can be polled, and `poll` returns a `Poll`.

```
use std::pin::Pin;
use std::task::Context;

pub trait Future {
    type Output;
    fn poll(self: Pin<&mut Self>, cx: &mut Context<'_>) -> Poll<Self::Output>;
}

pub enum Poll<T> {
    Ready(T),
    Pending,
}
```

An async function returns an `impl Future`. It's also possible (but uncommon) to implement `Future` for your own types. For example, the `JoinHandle` returned from `tokio::spawn` implements `Future` to allow joining to it.

The `.await` keyword, applied to a `Future`, causes the current async function to pause until that `Future` is ready, and then evaluates to its output.

## ▼ *Speaker Notes*

This slide should take about 4 minutes.

- The `Future` and `Poll` types are implemented exactly as shown; click the links to show the implementations in the docs.
- We will not get to `Pin` and `Context`, as we will focus on writing async code, rather than building new async primitives. Briefly:
  - `Context` allows a `Future` to schedule itself to be polled again when an event occurs.
  - `Pin` ensures that the `Future` isn't moved in memory, so that pointers into that future remain valid. This is required to allow references to remain valid after an `.await`.

# Runtimes

A *runtime* provides support for performing operations asynchronously (a *reactor*) and is responsible for executing futures (an *executor*). Rust does not have a “built-in” runtime, but several options are available:

- [Tokio](#): performant, with a well-developed ecosystem of functionality like [Hyper](#) for HTTP or [Tonic](#) for gRPC.
- [async-std](#): aims to be a “std for async”, and includes a basic runtime in `async::task`.
- [smol](#): simple and lightweight

Several larger applications have their own runtimes. For example, [Fuchsia](#) already has one.

## ▼ *Speaker Notes*

This slide and its sub-slides should take about 10 minutes.

- Note that of the listed runtimes, only Tokio is supported in the Rust playground. The playground also does not permit any I/O, so most interesting async things can't run in the playground.
- Futures are “inert” in that they do not do anything (not even start an I/O operation) unless there is an executor polling them. This differs from JS Promises, for example, which will run to completion even if they are never used.

# Tokio

Tokio provides:

- A multi-threaded runtime for executing asynchronous code.
- An asynchronous version of the standard library.
- A large ecosystem of libraries.

```
1 use tokio::time;
2
3 async fn count_to(count: i32) {
4     for i in 0..count {
5         println!("Count in task: {i}!");
6         time::sleep(time::Duration::from_millis(5)).await;
7     }
8 }
9
10 #[tokio::main]
11 async fn main() {
12     tokio::spawn(count_to(10));
13
14     for i in 0..5 {
15         println!("Main task: {i}");
16         time::sleep(time::Duration::from_millis(5)).await;
17     }
18 }
```

## ▼ Speaker Notes

- With the `tokio::main` macro we can now make `main` `async`.
- The `spawn` function creates a new, concurrent “task”.
- Note: `spawn` takes a `Future`, you don’t call `.await` on `count_to`.

## Further exploration:

- Why does `count_to` not (usually) get to 10? This is an example of `async` cancellation. `tokio::spawn` returns a handle which can be awaited to wait until it finishes.
- Try `count_to(10).await` instead of spawning.
- Try awaiting the task returned from `tokio::spawn`.

# Tasks

Rust has a task system, which is a form of lightweight threading.

A task has a single top-level future which the executor polls to make progress. That future may have one or more nested futures that its `poll` method polls, corresponding loosely to a call stack. Concurrency within a task is possible by polling multiple child futures, such as racing a timer and an I/O operation.

```
use tokio::io::{self, AsyncReadExt, AsyncWriteExt};
use tokio::net::TcpListener;

#[tokio::main]
async fn main() -> io::Result<()> {
    let listener = TcpListener::bind("127.0.0.1:0").await?;
    println!("listening on port {}", listener.local_addr()?.port());

    loop {
        let (mut socket, addr) = listener.accept().await?;

        println!("connection from {addr:?}");

        tokio::spawn(async move {
            socket.write_all(b"Who are you?\n").await.expect("socket error");

            let mut buf = vec![0; 1024];
            let name_size = socket.read(&mut buf).await.expect("socket error");
            let name = std::str::from_utf8(&buf[..name_size]).unwrap().trim();
            let reply = format!("Thanks for dialing in, {name}!\n");
            socket.write_all(reply.as_bytes()).await.expect("socket error");
        });
    }
}
```

## ▼ Speaker Notes

This slide should take about 6 minutes.

Copy this example into your prepared `src/main.rs` and run it from there.

Try connecting to it with a TCP connection tool like `nc` or `telnet`.

- Ask students to visualize what the state of the example server would be with a few connected clients. What tasks exist? What are their Futures?
- This is the first time we've seen an `async` block. This is similar to a closure, but does not take any arguments. Its return value is a Future, similar to an `async fn`.

- Refactor the async block into a function, and improve the error handling using `?`.

# Channels and Control Flow

This segment should take about 20 minutes. It contains:

Slide	Duration
Async Channels	10 minutes
Join	4 minutes
Select	5 minutes

# Async Channels

Several crates have support for asynchronous channels. For instance `tokio`:

```

1 use tokio::sync::mpsc;
2
3 async fn ping_handler(mut input: mpsc::Receiver<()>) {
4     let mut count: usize = 0;
5
6     while let Some(_) = input.recv().await {
7         count += 1;
8         println!("Received {count} pings so far.");
9     }
10
11     println!("ping_handler complete");
12 }
13
14 #[tokio::main]
15 async fn main() {
16     let (sender, receiver) = mpsc::channel(32);
17     let ping_handler_task = tokio::spawn(ping_handler(receiver));
18     for i in 0..10 {
19         sender.send(()).await.expect("Failed to send ping.");
20         println!("Sent {} pings so far.", i + 1);
21     }
22
23     drop(sender);
24     ping_handler_task.await.expect("Something went wrong in ping handler task.");
25 }

```

## ▼ Speaker Notes

This slide should take about 8 minutes.

- Change the channel size to `3` and see how it affects the execution.
- Overall, the interface is similar to the `sync` channels as seen in the [morning class](#).
- Try removing the `std::mem::drop` call. What happens? Why?
- The [Flume](#) crate has channels that implement both `sync` and `async` `send` and `recv`. This can be convenient for complex applications with both IO and heavy CPU processing tasks.
- What makes working with `async` channels preferable is the ability to combine them with other `future`s to combine them and create complex control flow.

# Join

A join operation waits until all of a set of futures are ready, and returns a collection of their results. This is similar to `Promise.all` in JavaScript or `asyncio.gather` in Python.

```
1 use anyhow::Result;
2 use futures::future;
3 use reqwest;
4 use std::collections::HashMap;
5
6 async fn size_of_page(url: &str) -> Result<usize> {
7     let resp = reqwest::get(url).await?;
8     Ok(resp.text().await?.len())
9 }
10
11 #[tokio::main]
12 async fn main() {
13     let urls: [&str; 4] = [
14         "https://google.com",
15         "https://httpbin.org/ip",
16         "https://play.rust-lang.org/",
17         "BAD_URL",
18     ];
19     let futures_iter = urls.into_iter().map(size_of_page);
20     let results = future::join_all(futures_iter).await;
21     let page_sizes_dict: HashMap<&str, Result<usize>> =
22         urls.into_iter().zip(results.into_iter()).collect();
23     println!("{page_sizes_dict:?}");
24 }
```

## ▼ Speaker Notes

This slide should take about 4 minutes.

Copy this example into your prepared `src/main.rs` and run it from there.

- For multiple futures of disjoint types, you can use `std::future::join!` but you must know how many futures you will have at compile time. This is currently in the `futures` crate, soon to be stabilised in `std::future`.
- The risk of `join` is that one of the futures may never resolve, this would cause your program to stall.
- You can also combine `join_all` with `join!` for instance to join all requests to an http service as well as a database query. Try adding a `tokio::time::sleep` to the future,



using `futures::join!`. This is not a timeout (that requires `select!`, explained in the next chapter), but demonstrates `join!`.

# Select

A select operation waits until any of a set of futures is ready, and responds to that future's result. In JavaScript, this is similar to `Promise.race`. In Python, it compares to `asyncio.wait(task_set, return_when=asyncio.FIRST_COMPLETED)`.

Similar to a match statement, the body of `select!` has a number of arms, each of the form `pattern = future => statement`. When a `future` is ready, its return value is destructured by the `pattern`. The `statement` is then run with the resulting variables. The `statement` result becomes the result of the `select!` macro.

```

1 use tokio::sync::mpsc;
2 use tokio::time::{sleep, Duration};
3
4 #[tokio::main]
5 async fn main() {
6     let (tx, mut rx) = mpsc::channel(32);
7     let listener = tokio::spawn(async move {
8         tokio::select! {
9             Some(msg) = rx.recv() => println!("got: {msg}"),
10            _ = sleep(Duration::from_millis(50)) => println!("timeout"),
11        };
12    });
13    sleep(Duration::from_millis(10)).await;
14    tx.send(String::from("Hello!")).await.expect("Failed to send greeting");
15
16    listener.await.expect("Listener failed");
17 }
```

## ▼ Speaker Notes

This slide should take about 5 minutes.

- The `listener` `async` block here is a common form: wait for some `async` event, or for a timeout. Change the `sleep` to sleep longer to see it fail. Why does the `send` also fail in this situation?
- `select!` is also often used in a loop in “actor” architectures, where a task reacts to events in a loop. That has some pitfalls, which will be discussed in the next segment.

# Pitfalls

Async / await provides convenient and efficient abstraction for concurrent asynchronous programming. However, the async/await model in Rust also comes with its share of pitfalls and footguns. We illustrate some of them in this chapter.

This segment should take about 55 minutes. It contains:

Slide	Duration
Blocking the Executor	10 minutes
Pin	20 minutes
Async Traits	5 minutes
Cancellation	20 minutes

# Blocking the executor

Most async runtimes only allow IO tasks to run concurrently. This means that CPU blocking tasks will block the executor and prevent other tasks from being executed. An easy workaround is to use async equivalent methods where possible.

```

1 use futures::future::join_all;
2 use std::time::Instant;
3
4 async fn sleep_ms(start: &Instant, id: u64, duration_ms: u64) {
5     std::thread::sleep(std::time::Duration::from_millis(duration_ms));
6     println!(
7         "future {id} slept for {duration_ms}ms, finished after {}ms",
8         start.elapsed().as_millis()
9     );
10 }
11
12 #[tokio::main(flavor = "current_thread")]
13 async fn main() {
14     let start = Instant::now();
15     let sleep_futures = (1..=10).map(|t| sleep_ms(&start, t, t * 10));
16     join_all(sleep_futures).await;
17 }

```

## ▼ Speaker Notes

This slide should take about 10 minutes.

- Run the code and see that the sleeps happen consecutively rather than concurrently.
- The "current\_thread" flavor puts all tasks on a single thread. This makes the effect more obvious, but the bug is still present in the multi-threaded flavor.
- Switch the `std::thread::sleep` to `tokio::time::sleep` and await its result.
- Another fix would be to `tokio::task::spawn_blocking` which spawns an actual thread and transforms its handle into a future without blocking the executor.
- You should not think of tasks as OS threads. They do not map 1 to 1 and most executors will allow many tasks to run on a single OS thread. This is particularly problematic when interacting with other libraries via FFI, where that library might depend on thread-local storage or map to specific OS threads (e.g., CUDA). Prefer `tokio::task::spawn_blocking` in such situations.
- Use sync mutexes with care. Holding a mutex over an `.await` may cause another task to block, and that task may be running on the same thread.

# Pin

Async blocks and functions return types implementing the `Future` trait. The type returned is the result of a compiler transformation which turns local variables into data stored inside the future.

Some of those variables can hold pointers to other local variables. Because of that, the future should never be moved to a different memory location, as it would invalidate those pointers.

To prevent moving the future type in memory, it can only be polled through a pinned pointer. `Pin` is a wrapper around a reference that disallows all operations that would move the instance it points to into a different memory location.

```

1 use tokio::sync::{mpsc, oneshot};
2 use tokio::task::spawn;
3 use tokio::time::{sleep, Duration};
4
5 // A work item. In this case, just sleep for the given time and respond
6 // with a message on the `respond_on` channel.
7 #[derive(Debug)]
8 struct Work {
9     input: u32,
10    respond_on: oneshot::Sender<u32>,
11 }
12
13 // A worker which listens for work on a queue and performs it.
14 async fn worker(mut work_queue: mpsc::Receiver<Work>) {
15     let mut iterations = 0;
16     loop {
17         tokio::select! {
18             Some(work) = work_queue.recv() => {
19                 sleep(Duration::from_millis(10)).await; // Pretend to work.
20                 work.respond_on
21                     .send(work.input * 1000)
22                     .expect("failed to send response");
23                 iterations += 1;
24             }
25             // TODO: report number of iterations every 100ms
26         }
27     }
28 }
29
30 // A requester which requests work and waits for it to complete.
31 async fn do_work(work_queue: &mpsc::Sender<Work>, input: u32) -> u32 {
32     let (tx, rx) = oneshot::channel();
33     work_queue
34         .send(Work { input, respond_on: tx })
35         .await
36         .expect("failed to send on work queue");
37     rx.await.expect("failed waiting for response")
38 }
39
40 #[tokio::main]
41 async fn main() {
42     let (tx, rx) = mpsc::channel(10);
43     spawn(worker(rx));
44     for i in 0..100 {
45         let resp = do_work(&tx, i).await;
46         println!("work result for iteration {i}: {resp}");
47     }
48 }

```

### ▼ Speaker Notes

This slide should take about 20 minutes.

- You may recognize this as an example of the actor pattern. Actors typically call `select!` in a loop.
- This serves as a summation of a few of the previous lessons, so take your time with it.
  - Naively add a `_ = sleep(Duration::from_millis(100)) => { println!(..) }` to the `select!`. This will never execute. Why?
  - Instead, add a `timeout_fut` containing that future outside of the `loop`:

```
let timeout_fut = sleep(Duration::from_millis(100));
loop {
    select! {
        ..,
        _ = timeout_fut => { println!(..); },
    }
}
```

- This still doesn't work. Follow the compiler errors, adding `&mut` to the `timeout_fut` in the `select!` to work around the move, then using `Box::pin`:

```
let mut timeout_fut = Box::pin(sleep(Duration::from_millis(100)));
loop {
    select! {
        ..,
        _ = &mut timeout_fut => { println!(..); },
    }
}
```

- This compiles, but once the timeout expires it is `Poll::Ready` on every iteration (a fused future would help with this). Update to reset `timeout_fut` every time it expires:

```
let mut timeout_fut = Box::pin(sleep(Duration::from_millis(100)));
loop {
    select! {
        _ = &mut timeout_fut => {
            println!(..);
            timeout_fut = Box::pin(sleep(Duration::from_millis(100)));
        },
    }
}
```

- `Box` allocates on the heap. In some cases, `std::pin::pin!` (only recently stabilized, with older code often using `tokio::pin!`) is also an option, but that is difficult to use for a future that is reassigned.
- Another alternative is to not use `pin` at all but spawn another task that will send to a `oneshot` channel every 100ms.
- Data that contains pointers to itself is called self-referential. Normally, the Rust borrow checker would prevent self-referential data from being moved, as the references cannot outlive the data they point to. However, the code transformation for async blocks and functions is not verified by the borrow checker.
- `Pin` is a wrapper around a reference. An object cannot be moved from its place using a pinned pointer. However, it can still be moved through an unpinned pointer.
- The `poll` method of the `Future` trait uses `Pin<&mut Self>` instead of `&mut Self` to refer to the instance. That's why it can only be called on a pinned pointer.



# Async Traits

Async methods in traits were stabilized in the 1.75 release. This required support for using return-position `impl Trait` in traits, as the desugaring for `async fn` includes `-> impl Future<Output = ...>`.

However, even with the native support, there are some pitfalls around `async fn`:

- Return-position `impl Trait` captures all in-scope lifetimes (so some patterns of borrowing cannot be expressed).
- Async traits cannot be used with [trait objects](#) (`dyn Trait` support).

The [async\\_trait](#) crate provides a workaround for `dyn` support through a macro, with some caveats:

```
1 use async_trait::async_trait;
2 use std::time::Instant;
3 use tokio::time::{sleep, Duration};
4
5 #[async_trait]
6 trait Sleeper {
7     async fn sleep(&self);
8 }
9
10 struct FixedSleeper {
11     sleep_ms: u64,
12 }
13
14 #[async_trait]
15 impl Sleeper for FixedSleeper {
16     async fn sleep(&self) {
17         sleep(Duration::from_millis(self.sleep_ms)).await;
18     }
19 }
20
21 async fn run_all_sleepers_multiple_times(
22     sleepers: Vec<Box<dyn Sleeper>>,
23     n_times: usize,
24 ) {
25     for _ in 0..n_times {
26         println!("Running all sleepers...");
27         for sleeper in &sleepers {
28             let start = Instant::now();
29             sleeper.sleep().await;
30             println!("Slept for {} ms", start.elapsed().as_millis());
31         }
32     }
33 }
34
35 #[tokio::main]
36 async fn main() {
37     let sleepers: Vec<Box<dyn Sleeper>> = vec![
38         Box::new(FixedSleeper { sleep_ms: 50 }),
39         Box::new(FixedSleeper { sleep_ms: 100 }),
40     ];
41     run_all_sleepers_multiple_times(sleepers, 5).await;
42 }
```

### ▼ Speaker Notes

This slide should take about 5 minutes.

- `async_trait` is easy to use, but note that it's using heap allocations to achieve this. This heap allocation has performance overhead.
- The challenges in language support for `async trait` are too deep to describe in-depth in this class. See [this blog post](#) by Niko Matsakis if you are interested in digging deeper.

See also these keywords:

- [RPIT](#): short for `return-position impl Trait`.
- [RPITIT](#): short for `return-position impl Trait in trait` (RPIT in trait).
- Try creating a new sleeper struct that will sleep for a random amount of time and adding it to the `Vec`.

# Cancellation

Dropping a future implies it can never be polled again. This is called *cancellation* and it can occur at any `await` point. Care is needed to ensure the system works correctly even when futures are cancelled. For example, it shouldn't deadlock or lose data.

```

1 use std::io;
2 use std::time::Duration;
3 use tokio::io::{AsyncReadExt, AsyncWriteExt, DuplexStream};
4
5 struct LinesReader {
6     stream: DuplexStream,
7 }
8
9 impl LinesReader {
10     fn new(stream: DuplexStream) -> Self {
11         Self { stream }
12     }
13
14     async fn next(&mut self) -> io::Result<Option<String>> {
15         let mut bytes = Vec::new();
16         let mut buf = [0];
17         while self.stream.read(&mut buf[..]).await? != 0 {
18             bytes.push(buf[0]);
19             if buf[0] == b'\n' {
20                 break;
21             }
22         }
23         if bytes.is_empty() {
24             return Ok(None);
25         }
26         let s = String::from_utf8(bytes)
27             .map_err(|_| io::Error::new(io::ErrorKind::InvalidData, "not UTF-8"))
28             .ok(Some(s))
29     }
30 }
31
32 async fn slow_copy(source: String, mut dest: DuplexStream) -> io::Result<()> {
33     for b in source.bytes() {
34         dest.write_u8(b).await?;
35         tokio::time::sleep(Duration::from_millis(10)).await
36     }
37     Ok(())
38 }
39
40 #[tokio::main]
41 async fn main() -> io::Result<()> {
42     let (client, server) = tokio::io::duplex(5);
43     let handle = tokio::spawn(slow_copy("hi\nthere\n".to_owned(), client));
44
45     let mut lines = LinesReader::new(server);
46     let mut interval = tokio::time::interval(Duration::from_millis(60));
47     loop {
48         tokio::select! {
49             _ = interval.tick() => println!("tick!"),
50             line = lines.next() => if let Some(l) = line? {
51                 print!("{}", l)
52             } else {
53                 break
54             },
55         }
56     }
57 }

```

```

56     }
57     handle.await.unwrap()?;
58     Ok(())
59 }

```

### ▼ Speaker Notes

This slide should take about 18 minutes.

- The compiler doesn't help with cancellation-safety. You need to read API documentation and consider what state your `async fn` holds.
- Unlike `panic` and `?`, cancellation is part of normal control flow (vs error-handling).
- The example loses parts of the string.
  - Whenever the `tick()` branch finishes first, `next()` and its `buf` are dropped.
  - `LinesReader` can be made cancellation-safe by making `buf` part of the struct:

```

struct LinesReader {
    stream: DuplexStream,
    bytes: Vec<u8>,
    buf: [u8; 1],
}

impl LinesReader {
    fn new(stream: DuplexStream) -> Self {
        Self { stream, bytes: Vec::new(), buf: [0] }
    }
    async fn next(&mut self) -> io::Result<Option<String>> {
        // prefix buf and bytes with self.
        // ...
        let raw = std::mem::take(&mut self.bytes);
        let s = String::from_utf8(raw)
            .map_err(|_| io::Error::new(io::ErrorKind::InvalidData,
                "not UTF-8"))?;
        // ...
    }
}

```

- `Interval::tick` is cancellation-safe because it keeps track of whether a tick has been 'delivered'.

- [AsyncReadExt::read](#) is cancellation-safe because it either returns or doesn't read data.
- [AsyncBufReadExt::read\\_line](#) is similar to the example and *isn't* cancellation-safe. See its documentation for details and alternatives.

# Exercises

This segment should take about 1 hour and 10 minutes. It contains:

Slide	Duration
Dining Philosophers	20 minutes
Broadcast Chat Application	30 minutes
Solutions	20 minutes



# Dining Philosophers — Async

See [dining philosophers](#) for a description of the problem.

As before, you will need a local [Cargo installation](#) for this exercise. Copy the code below to a file called `src/main.rs`, fill out the blanks, and test that `cargo run` does not deadlock:

```
use std::sync::Arc;
use tokio::sync::{mpsc, Mutex};
use tokio::time;

struct Chopstick;

struct Philosopher {
    name: String,
    // left_chopstick: ...
    // right_chopstick: ...
    // thoughts: ...
}

impl Philosopher {
    async fn think(&self) {
        self.thoughts
            .send(format!("Eureka! {} has a new idea!", &self.name))
            .await
            .unwrap();
    }

    async fn eat(&self) {
        // Keep trying until we have both chopsticks
        println!("{}", &self.name);
        time::sleep(time::Duration::from_millis(5)).await;
    }
}

// tokio scheduler doesn't deadlock with 5 philosophers, so have 2.
static PHILOSOPHERS: &[&str] = &["Socrates", "Hypatia"];

#[tokio::main]
async fn main() {
    // Create chopsticks

    // Create philosophers

    // Make them think and eat

    // Output their thoughts
}
```

Since this time you are using Async Rust, you'll need a `tokio` dependency. You can use the following `Cargo.toml`:

```
[package]
name = "dining-philosophers-async-dine"
version = "0.1.0"
edition = "2021"

[dependencies]
tokio = { version = "1.26.0", features = ["sync", "time", "macros", "rt-multi-thread"] }
```

Also note that this time you have to use the `Mutex` and the `mpsc` module from the `tokio` crate.

#### ▼ *Speaker Notes*

This slide should take about 20 minutes.

- Can you make your implementation single-threaded?

# Broadcast Chat Application

In this exercise, we want to use our new knowledge to implement a broadcast chat application. We have a chat server that the clients connect to and publish their messages. The client reads user messages from the standard input, and sends them to the server. The chat server broadcasts each message that it receives to all the clients.

For this, we use a [broadcast channel](#) on the server, and [tokio\\_websockets](#) for the communication between the client and the server.

Create a new Cargo project and add the following dependencies:

*Cargo.toml*:

```
[package]
name = "chat-async"
version = "0.1.0"
edition = "2021"

[dependencies]
futures-util = { version = "0.3.31", features = ["sink"] }
http = "1.2.0"
tokio = { version = "1.43.0", features = ["full"] }
tokio-websockets = { version = "0.11.3", features = ["client", "fastrand", "server", "sha1_smol"] }
```

## The required APIs

You are going to need the following functions from [tokio](#) and [tokio\\_websockets](#). Spend a few minutes to familiarize yourself with the API.

- [StreamExt::next\(\)](#) implemented by `WebSocketStream`: for asynchronously reading messages from a Websocket Stream.
- [SinkExt::send\(\)](#) implemented by `WebSocketStream`: for asynchronously sending messages on a Websocket Stream.
- [Lines::next\\_line\(\)](#): for asynchronously reading user messages from the standard input.
- [Sender::subscribe\(\)](#): for subscribing to a broadcast channel.

## Two binaries

Normally in a Cargo project, you can have only one binary, and one `src/main.rs` file. In this project, we need two binaries. One for the client, and one for the server. You could potentially make them two separate Cargo projects, but we are going to put them in a single Cargo project with two binaries. For this to work, the client and the server code should go under `src/bin` (see the [documentation](#)).

Copy the following server and client code into `src/bin/server.rs` and `src/bin/client.rs`, respectively. Your task is to complete these files as described below.

*src/bin/server.rs:*

```
use futures_util::sink::SinkExt;
use futures_util::stream::StreamExt;
use std::error::Error;
use std::net::SocketAddr;
use tokio::net::{TcpListener, TcpStream};
use tokio::sync::broadcast::{channel, Sender};
use tokio_websockets::{Message, ServerBuilder, WebSocketStream};

async fn handle_connection(
    addr: SocketAddr,
    mut ws_stream: WebSocketStream<TcpStream>,
    bcast_tx: Sender<String>,
) -> Result<(), Box<dyn Error + Send + Sync>> {

    // TODO: For a hint, see the description of the task below.

}

#[tokio::main]
async fn main() -> Result<(), Box<dyn Error + Send + Sync>> {
    let (bcast_tx, _) = channel(16);

    let listener = TcpListener::bind("127.0.0.1:2000").await?;
    println!("listening on port 2000");

    loop {
        let (socket, addr) = listener.accept().await?;
        println!("New connection from {addr:?}");
        let bcast_tx = bcast_tx.clone();
        tokio::spawn(async move {
            // Wrap the raw TCP stream into a websocket.
            let (_req, ws_stream) = ServerBuilder::new().accept(socket).await?;

            handle_connection(addr, ws_stream, bcast_tx).await
        });
    }
}
```

*src/bin/client.rs:*

```
use futures_util::stream::StreamExt;
use futures_util::SinkExt;
use http::Uri;
use tokio::io::{AsyncBufReadExt, BufReader};
use tokio_websockets::{ClientBuilder, Message};

#[tokio::main]
async fn main() -> Result<(), tokio_websockets::Error> {
    let (mut ws_stream, _) =
        ClientBuilder::from_uri(Uri::from_static("ws://127.0.0.1:2000"))
            .connect()
            .await?;

    let stdin = tokio::io::stdin();
    let mut stdin = BufReader::new(stdin).lines();

    // TODO: For a hint, see the description of the task below.
}
```

## Running the binaries

Run the server with:

```
cargo run --bin server
```

and the client with:

```
cargo run --bin client
```

## Tasks

- Implement the `handle_connection` function in `src/bin/server.rs`.
  - Hint: Use `tokio::select!` for concurrently performing two tasks in a continuous loop. One task receives messages from the client and broadcasts them. The other sends messages received by the server to the client.
- Complete the main function in `src/bin/client.rs`.
  - Hint: As before, use `tokio::select!` in a continuous loop for concurrently performing two tasks: (1) reading user messages from standard input and sending

them to the server, and (2) receiving messages from the server, and displaying them for the user.

- Optional: Once you are done, change the code to broadcast messages to all clients, but the sender of the message.



# Solutions

## Dining Philosophers — Async

```

use std::sync::Arc;
use tokio::sync::{mpsc, Mutex};
use tokio::time;

struct Chopstick;

struct Philosopher {
    name: String,
    left_chopstick: Arc<Mutex<Chopstick>>,
    right_chopstick: Arc<Mutex<Chopstick>>,
    thoughts: mpsc::Sender<String>,
}

impl Philosopher {
    async fn think(&self) {
        self.thoughts
            .send(format!("Eureka! {} has a new idea!", &self.name))
            .await
            .unwrap();
    }

    async fn eat(&self) {
        // Keep trying until we have both chopsticks
        // Pick up chopsticks...
        let _left_chopstick = self.left_chopstick.lock().await;
        let _right_chopstick = self.right_chopstick.lock().await;

        println!("{}", &self.name);
        time::sleep(time::Duration::from_millis(5)).await;

        // The locks are dropped here
    }
}

// tokio scheduler doesn't deadlock with 5 philosophers, so have 2.
static PHILOSOPHERS: &[&str] = &["Socrates", "Hypatia"];

#[tokio::main]
async fn main() {
    // Create chopsticks
    let mut chopsticks = vec![];
    PHILOSOPHERS
        .iter()
        .for_each(|_| chopsticks.push(Arc::new(Mutex::new(Chopstick))));
}

```



```

// Create philosophers
let (philosophers, mut rx) = {
    let mut philosophers = vec![];
    let (tx, rx) = mpsc::channel(10);
    for (i, name) in PHILOSOPHERS.iter().enumerate() {
        let mut left_chopstick = Arc::clone(&chopsticks[i]);
        let mut right_chopstick =
            Arc::clone(&chopsticks[(i + 1) % PHILOSOPHERS.len()]);
        if i == PHILOSOPHERS.len() - 1 {
            std::mem::swap(&mut left_chopstick, &mut right_chopstick);
        }
        philosophers.push(Philosopher {
            name: name.to_string(),
            left_chopstick,
            right_chopstick,
            thoughts: tx.clone(),
        });
    }
    (philosophers, rx)
    // tx is dropped here, so we don't need to explicitly drop it later
};

// Make them think and eat
for phil in philosophers {
    tokio::spawn(async move {
        for _ in 0..100 {
            phil.think().await;
            phil.eat().await;
        }
    });
}

// Output their thoughts
while let Some(thought) = rx.recv().await {
    println!("Here is a thought: {thought}");
}
}

```

## Broadcast Chat Application

*src/bin/server.rs:*

```

use futures_util::sink::SinkExt;
use futures_util::stream::StreamExt;
use std::error::Error;
use std::net::SocketAddr;
use tokio::net::{TcpListener, TcpStream};
use tokio::sync::broadcast::{channel, Sender};
use tokio_websockets::{Message, ServerBuilder, WebSocketStream};

async fn handle_connection(
    addr: SocketAddr,
    mut ws_stream: WebSocketStream<TcpStream>,
    bcast_tx: Sender<String>,
) -> Result<(), Box<dyn Error + Send + Sync>> {

    ws_stream
        .send(Message::text("Welcome to chat! Type a message".to_string()))
        .await?;
    let mut bcast_rx = bcast_tx.subscribe();

    // A continuous loop for concurrently performing two tasks: (1) receiving
    // messages from `ws_stream` and broadcasting them, and (2) receiving
    // messages on `bcast_rx` and sending them to the client.
    loop {
        tokio::select! {
            incoming = ws_stream.next() => {
                match incoming {
                    Some(Ok(msg)) => {
                        if let Some(text) = msg.as_text() {
                            println!("From client {addr:?} {text:?}");
                            bcast_tx.send(text.into())?;
                        }
                    }
                    Some(Err(err)) => return Err(err.into()),
                    None => return Ok(()),
                }
            }
            msg = bcast_rx.recv() => {
                ws_stream.send(Message::text(msg?)).await?;
            }
        }
    }
}

#[tokio::main]
async fn main() -> Result<(), Box<dyn Error + Send + Sync>> {
    let (bcast_tx, _) = channel(16);

    let listener = TcpListener::bind("127.0.0.1:2000").await?;
    println!("listening on port 2000");

    loop {
        let (socket, addr) = listener.accept().await?;
        println!("New connection from {addr:?}");
        let bcast_tx = bcast_tx.clone();

```

```
tokio::spawn(async move {  
    // Wrap the raw TCP stream into a websocket.  
    let (_req, ws_stream) = ServerBuilder::new().accept(socket).await?;  
  
    handle_connection(addr, ws_stream, bcast_tx).await  
});  
}
```

*src/bin/client.rs:*



# Thanks!

*Thank you for taking Comprehensive Rust 🦀! We hope you enjoyed it and that it was useful.*

We've had a lot of fun putting the course together. The course is not perfect, so if you spotted any mistakes or have ideas for improvements, please get in [contact with us on GitHub](#). We would love to hear from you.

## ▼ *Speaker Notes*

- Thank you for reading the speaker notes! We hope they have been useful. If you find pages without notes, please send us a PR and link it to [issue #1083](#). We are also very grateful for fixes and improvements to the existing notes.

# Glossary

The following is a glossary which aims to give a short definition of many Rust terms. For translations, this also serves to connect the term back to the English original.

**allocate:**

Dynamic memory allocation on [the heap](#).

**argument:**

Information that is passed into a function or method.

**associated type:**

A type associated with a specific trait. Useful for defining the relationship between types.

**Bare-metal Rust:**

Low-level Rust development, often deployed to a system without an operating system.

See [Bare-metal Rust](#).

**block:**

See [Blocks](#) and *scope*.

**borrow:**

See [Borrowing](#).

**borrow checker:**

The part of the Rust compiler which checks that all borrows are valid.

**brace:**

{ and } . Also called *curly brace*, they delimit *blocks*.

**build:**

The process of converting source code into executable code or a usable program.

**call:**

To invoke or execute a function or method.

**channel:**

Used to safely pass messages [between threads](#).

**Comprehensive Rust  :**

The courses here are jointly called Comprehensive Rust  .

**concurrency:**

The execution of multiple tasks or processes at the same time.

**Concurrency in Rust:**

See [Concurrency in Rust](#).

**constant:**

A value that does not change during the execution of a program.

**control flow:**

The order in which the individual statements or instructions are executed in a program.

**crash:**

An unexpected and unhandled failure or termination of a program.

**enumeration:**

A data type that holds one of several named constants, possibly with an associated tuple or struct.

**error:**

An unexpected condition or result that deviates from the expected behavior.

**error handling:**

The process of managing and responding to errors that occur during program execution.

**exercise:**

A task or problem designed to practice and test programming skills.

**function:**

A reusable block of code that performs a specific task.

**garbage collector:**

A mechanism that automatically frees up memory occupied by objects that are no longer in use.

**generics:**

A feature that allows writing code with placeholders for types, enabling code reuse with different data types.

**immutable:**

Unable to be changed after creation.

**integration test:**

A type of test that verifies the interactions between different parts or components of a system.

**keyword:**

A reserved word in a programming language that has a specific meaning and cannot be used as an identifier.

**library:**

A collection of precompiled routines or code that can be used by programs.

**macro:**

Rust macros can be recognized by a `!` in the name. Macros are used when normal functions are not enough. A typical example is `format!`, which takes a variable number of arguments, which isn't supported by Rust functions.

**main function:**

Rust programs start executing with the `main` function.

**match:**

A control flow construct in Rust that allows for pattern matching on the value of an expression.

**memory leak:**

A situation where a program fails to release memory that is no longer needed, leading to a gradual increase in memory usage.

**method:**

A function associated with an object or a type in Rust.

**module:**

A namespace that contains definitions, such as functions, types, or traits, to organize code in Rust.

**move:**

The transfer of ownership of a value from one variable to another in Rust.

**mutable:**

A property in Rust that allows variables to be modified after they have been declared.

**ownership:**

The concept in Rust that defines which part of the code is responsible for managing the memory associated with a value.

**panic:**

An unrecoverable error condition in Rust that results in the termination of the program.

**parameter:**

A value that is passed into a function or method when it is called.

**pattern:**

A combination of values, literals, or structures that can be matched against an expression in Rust.

**payload:**

The data or information carried by a message, event, or data structure.

**program:**

A set of instructions that a computer can execute to perform a specific task or solve a particular problem.

**programming language:**

A formal system used to communicate instructions to a computer, such as Rust.

**receiver:**

The first parameter in a Rust method that represents the instance on which the method is called.

**reference counting:**

A memory management technique in which the number of references to an object is tracked, and the object is deallocated when the count reaches zero.

**return:**

A keyword in Rust used to indicate the value to be returned from a function.

**Rust:**

A systems programming language that focuses on safety, performance, and concurrency.

**Rust Fundamentals:**

Days 1 to 4 of this course.

**Rust in Android:**

See [Rust in Android](#).

**Rust in Chromium:**

See [Rust in Chromium](#).

**safe:**

Refers to code that adheres to Rust's ownership and borrowing rules, preventing memory-



related errors.

**scope:**

The region of a program where a variable is valid and can be used.

**standard library:**

A collection of modules providing essential functionality in Rust.

**static:**

A keyword in Rust used to define static variables or items with a `'static` lifetime.

**string:**

A data type storing textual data. See [Strings](#) for more.

**struct:**

A composite data type in Rust that groups together variables of different types under a single name.

**test:**

A Rust module containing functions that test the correctness of other functions.

**thread:**

A separate sequence of execution in a program, allowing concurrent execution.

**thread safety:**

The property of a program that ensures correct behavior in a multithreaded environment.

**trait:**

A collection of methods defined for an unknown type, providing a way to achieve polymorphism in Rust.

**trait bound:**

An abstraction where you can require types to implement some traits of your interest.

**tuple:**

A composite data type that contains variables of different types. Tuple fields have no names, and are accessed by their ordinal numbers.

**type:**

A classification that specifies which operations can be performed on values of a particular kind in Rust.

**type inference:**

The ability of the Rust compiler to deduce the type of a variable or expression.

**undefined behavior:**

Actions or conditions in Rust that have no specified result, often leading to unpredictable program behavior.

**union:**

A data type that can hold values of different types but only one at a time.

**unit test:**

Rust comes with built-in support for running small unit tests and larger integration tests. See [Unit Tests](#).

**unit type:**

Type that holds no data, written as a tuple with no members.

**unsafe:**

The subset of Rust which allows you to trigger *undefined behavior*. See [Unsafe Rust](#).

**variable:**

A memory location storing data. Variables are valid in a *scope*.

# Other Rust Resources

The Rust community has created a wealth of high-quality and free resources online.

## Official Documentation

The Rust project hosts many resources. These cover Rust in general:

**The Rust Programming Language:** the canonical free book about Rust. Covers the language in detail and includes a few projects for people to build.

**Rust By Example:** covers the Rust syntax via a series of examples which showcase different constructs. Sometimes includes small exercises where you are asked to expand on the code in the examples.

**Rust Standard Library:** full documentation of the standard library for Rust.

**The Rust Reference:** an incomplete book which describes the Rust grammar and memory model.

More specialized guides hosted on the official Rust site:

**The Rustonomicon:** covers unsafe Rust, including working with raw pointers and interfacing with other languages (FFI).

**Asynchronous Programming in Rust:** covers the new asynchronous programming model which was introduced after the Rust Book was written.

**The Embedded Rust Book:** an introduction to using Rust on embedded devices without an operating system.

## Unofficial Learning Material

A small selection of other guides and tutorial for Rust:

**Learn Rust the Dangerous Way:** covers Rust from the perspective of low-level C programmers.

**Rust for Embedded C Programmers:** covers Rust from the perspective of developers who write firmware in C.

**Rust for professionals:** covers the syntax of Rust using side-by-side comparisons with other languages such as C, C++, Java, JavaScript, and Python.

**Rust on Exercism:** 100+ exercises to help you learn Rust.

**Ferrous Teaching Material:** a series of small presentations covering both basic and advanced part of the Rust language. Other topics such as WebAssembly, and async/await are also covered.

**Advanced testing for Rust applications:** a self-paced workshop that goes beyond Rust's built-in testing framework. It covers `googletest`, snapshot testing, mocking as well as how to write your own custom test harness.

**Beginner's Series to Rust and Take your first steps with Rust:** two Rust guides aimed at new developers. The first is a set of 35 videos and the second is a set of 11 modules which covers Rust syntax and basic constructs.

**Learn Rust With Entirely Too Many Linked Lists:** in-depth exploration of Rust's memory management rules, through implementing a few different types of list structures.

Please see the [Little Book of Rust Books](#) for even more Rust books.

# Credits

The material here builds on top of the many great sources of Rust documentation. See the page on [other resources](#) for a full list of useful resources.

The material of Comprehensive Rust is licensed under the terms of the Apache 2.0 license, please see [LICENSE](#) for details.

## Rust by Example

Some examples and exercises have been copied and adapted from [Rust by Example](#). Please see the `third_party/rust-by-example/` directory for details, including the license terms.

## Rust on Exercism

Some exercises have been copied and adapted from [Rust on Exercism](#). Please see the `third_party/rust-on-exercism/` directory for details, including the license terms.

## CXX

The [Interoperability with C++](#) section uses an image from [CXX](#). Please see the `third_party/cxx/` directory for details, including the license terms.